

# A New Test Facility for Probe Calibration - Offering Independent Variation of Mach and Reynolds Number

P.-A. Gieß, H.-J. Rehder, F. Kost

German Aerospace Center (DLR)  
Institute of Propulsion Technology  
Göttingen, Germany

## Abstract

At DLR, Göttingen, a new facility for probe calibration was built where dried air is driven by two compressors forming a closed circuit system with a free jet test section. Mach number and Reynolds number are the parameters to be varied while the total temperature is kept constant at  $T_0 \approx 298K$  ( $25^\circ C$ ). The Mach number covers the range from  $Ma = 0.3$  to  $1.6$  and will be extended down to  $Ma \approx 0.2$  and up to  $\approx 1.8$  when some modifications in the circuit will be installed. Variation of the Reynolds number is possible via the total pressure which can range from  $p_0 \approx 30kPa$  up to  $300kPa$ .

There are different axisymmetric nozzles with an exit diameter up to 50 mm to achieve different Mach numbers. First a convergent nozzle covers the subsonic range, second a slotted nozzle is used within the transonic range and third three Laval nozzles are available for supersonic Mach numbers ( $Ma = 1.4, 1.5$  and  $1.6$ ).

The orientation of the probe head positioned downstream of the exit plane on the centre line of the nozzle flow can be varied from  $-22^\circ$  up to  $+22^\circ$  for both the angle of attack and the yaw angle using stepping motors. Data acquisition is done by means of a PSI-module (for the most important pressures) and a SIMATIC operating system from Siemens, while the automatic data collection and a first evaluation is done using a software based on LabVIEW.

First measurements of the jet quality at different distances from the nozzle exit plane showed that the flow field is well suited for probe calibrations. Then two probes, a pyramid probe to be used in 3D flow fields and a wedge type probe to be used in 2D flow fields were calibrated. These results were already applied when wake traverses were performed in the Wind Tunnel for Straight Cascades (EGG) at DLR, Göttingen.

The technical set up of the wind tunnel, first measurements concerning the flow quality and some results of probe calibration will be presented.

## List of symbols

$c_d$	discharge coefficient
$d$	diameter of the nozzle
$l$	design length of the nozzle (supersonic part)
$Ma$	local Mach number
$p$	pressure
$R$	gas constant
$Re$	Reynolds number
$T$	temperature
$w$	flow velocity
$x, y, z$	coordinates (x at nozzle axis)
$\rho$	density

## Subscripts

0	total (i.e. $p_0$ total pressure)
$tc$	test chamber
$e$	nozzle exit
$p$	probe reading
$sc$	settling chamber

## Abbreviations

EGG	Wind Tunnel for Straight Cascades
RGG	Wind Tunnel for Rotating Cascades
SEG	Wind Tunnel for Probe Calibration

## 1. Introduction

Pneumatic probes are still a useful tool when investigating flow fields within turbomachines, cascades or any other aerodynamic facility. Due to the fact that flow velocity and flow direction cannot be measured directly by the probes as well as due to some inaccuracies when manufacturing the probe's head a calibration process is necessary. For this purpose there is the need of a wind tunnel giving flow conditions well known and constant within a wide range of Mach numbers and Reynolds numbers and also within a wide range of flow angles (pitch and yaw angles).

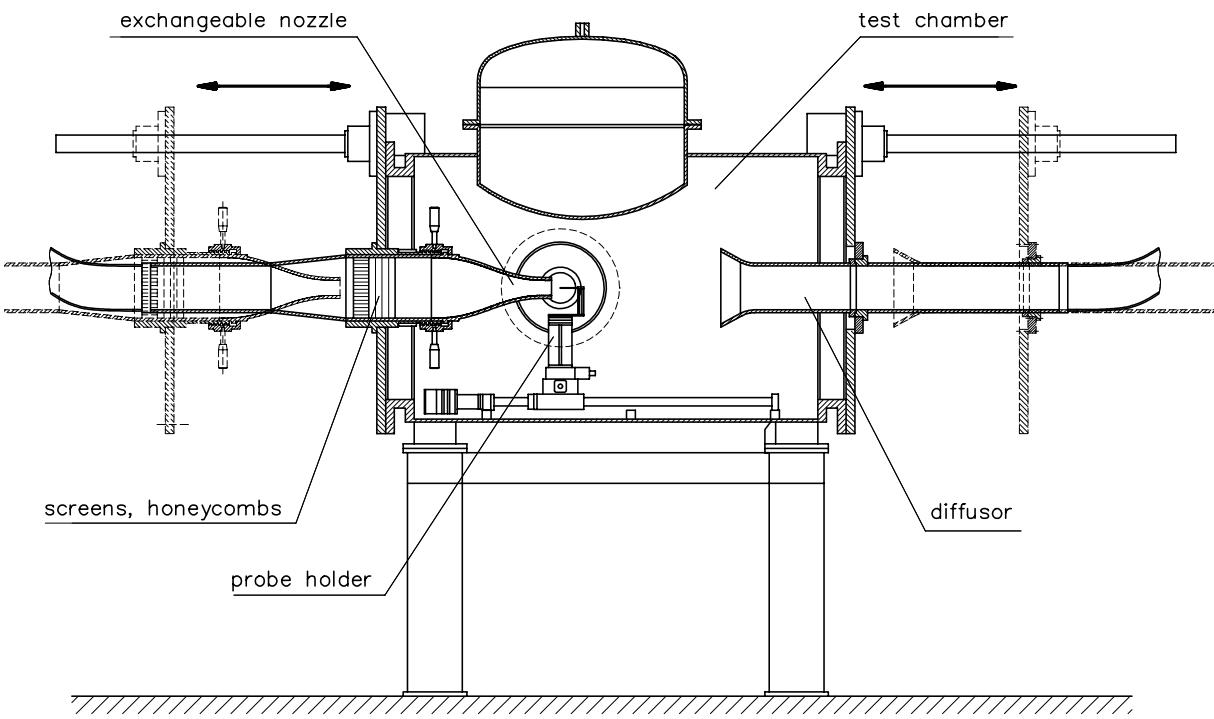

Figure 1: Test facility for probe calibration (SEG)

Difficulties arise when a wind tunnel test section designed for a special aerodynamic task has to be modified for calibration purposes. Problems often concern the flow quality, some geometric restrictions when introducing different probes, and others. Additionally there are significant costs except it is possible to use existent components such as a test chamber, a test section or an power system.

At DLR it was possible to use two compressors already existent for coolant ejection in the Wind Tunnel for Rotating Cascades (RGG) additionally to drive air in a closed cycle. Therefore a test section could be built up especially designed for probe calibration. An easily exchangeable support enables flexibility when inserting

very different types of probes.

## 2. Test facility

### 2.1 Description of the wind tunnel

A first study concerning a wind tunnel for probe calibration (SEG) at DLR using a free jet test section was given in [1]. Based on that proposal a wind tunnel was designed, where a compressor drives the fluid (dried air) in a closed cycle. The test section itself - a free jet downstream of an exchangeable nozzle enabling a wide range of Mach numbers - is positioned inside of a big chamber. A sketch of the wind tunnel together with an inserted probe is shown in figure 1 and the open wind tunnel in figure 2 while figure 3 presents schematically the whole circuit of the facility.

The wind tunnel operates using one or both of the two compressors; the data of which are given in table 1 to-

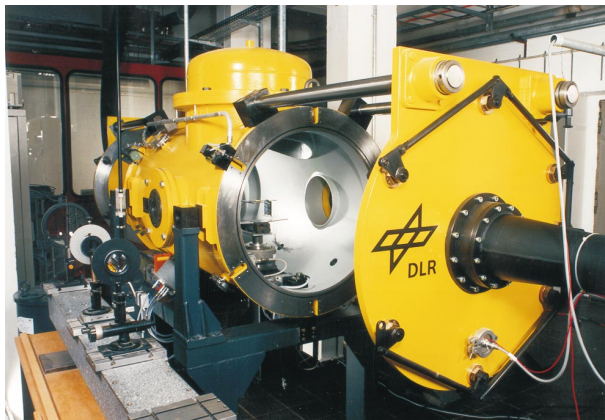

Figure 2: Photo of the open wind tunnel with a probe installed for calibration

nozzle diameter	$d_e = 50mm$
total pressure	30 kPa - 290 kPa
total temperature	295K - 315K
Mach number	0.3 - 1.6
Reynolds number	$0.1 - 2.1 \times 10^6$
run time	continuous
installed power	$2 \times 90 \text{ kW}$ / compressor
pressure ratio	3.0
volume flow	$0.43 \text{ m}^3/s$

Table 1: Some data of the wind tunnel

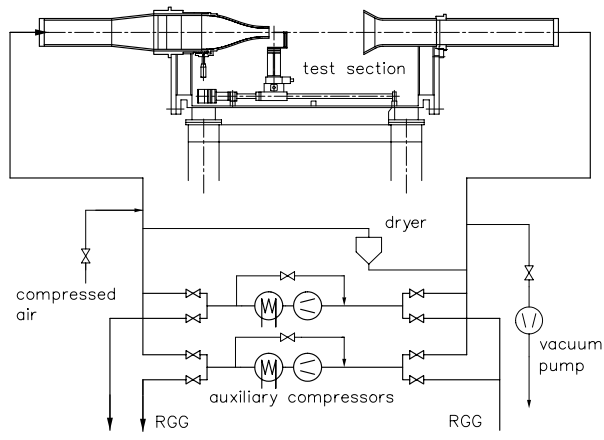

Figure 3: Circuit of SEG (schematic)

gether with the operating range of the wind tunnel. In-between of the compressor and the test chamber there is a cooler to keep the total temperature of the fluid constant at about  $T_{01} \approx 298K$ . The facility is connected to the local supply of pressurized air, first to get dry air and second to vary the total pressure of the fluid up to  $\approx 290kPa$ . Additionally there is a connection to a vacuum pump to reduce the total pressure down to  $\approx 30kPa$ . Therefore, an independent variation of the Mach number and of the Reynolds number is achieved. In the settling chamber upstream of the nozzle inlet there are a flow straightener and three screens to serve for a homogeneous flow field at a low level of turbulence. Downstream of the nozzle exit the free jet enters a diffuser to reverse some kinetic energy into pressure rise. Therefore the pressure ratio ( $p_{tc}/p_0$ ) in the test section can be decreased below the ratio delivered by the compressor.

Variation of the Mach number is done by varying the ratio of the pressure in the test chamber and the total pressure. For that reason there are several axisymmetric nozzles available which can be exchanged easily. Contours of different nozzles are shown in figure 4.

### 2.1.1 Subsonic nozzle design

To cover the subsonic range an axisymmetric convergent nozzle ( $d_{sc} = 200mm$ ,  $d_e = 50mm$ ) is used (contraction ratio of 16). The contour of the convergent part up to the throat was taken from polynomial functions according to [2].

First measurements of the total pressure and of the static pressure within the free jet downstream of the nozzle exit prove that there is a homogeneous flow field up to 60% of the nozzle exit diameter and up to a distance of about  $2.5 \times d_e$ ; outside this core regime the local total pressure rapidly decreases down to 75% of its value in the settling chamber, [3].

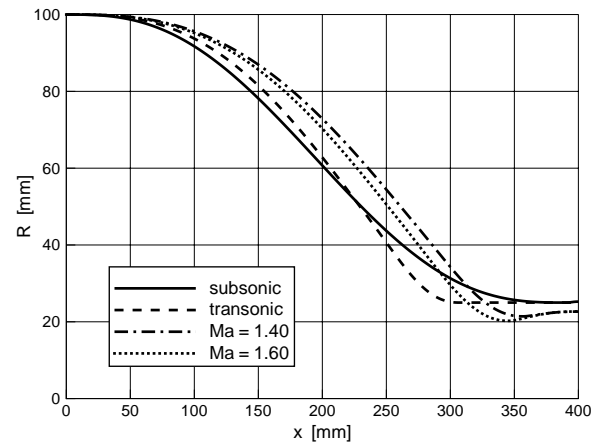

Figure 4: Contours of different nozzles

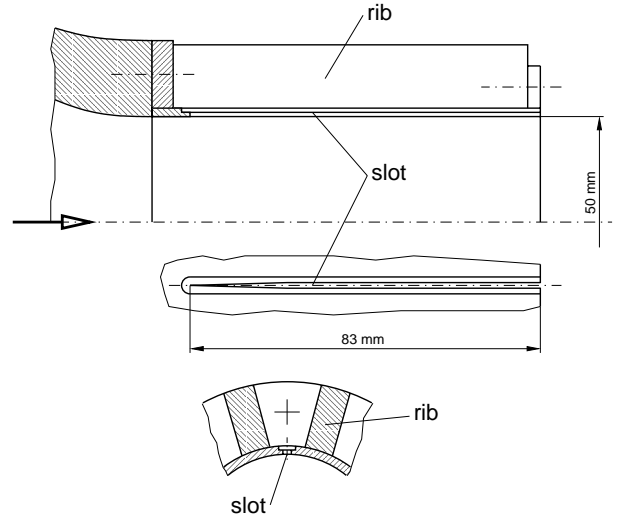

Figure 5: Sketch of the slotted nozzle

### 2.1.2 Transonic nozzle design

To cover the transonic range a nozzle is used consisting of a fixed convergent contour up to the throat located at  $\approx 300mm$  and an exchangeable slotted cylinder (figure 5) from the throat to the exit plane. Upstream of the throat the subsonic flow is accelerated smoothly to  $Ma = 1.0$ . The width of the 12 slots distributed aequidistantly on the perimeter of the cylinder should be designed in such a way that the Mach number smoothly reaches the desired supersonic level at the nozzle exit.

A very simple geometry of the slots (triangles) was given in [4] and applied up to  $Ma_e = 1.8$ . A modified configuration was expected to be used at Mach numbers  $Ma_e \leq 1.3$  at least.

However, measurements showed that the nozzle works well only up to Mach numbers of  $Ma_e \approx 1.1$ . At higher Mach numbers there is an overexpansion inside the nozzle and downstream of the exit plane resulting in considerable gradients of the local flow velocity. Therefore this flow field is not suitable for probe calibration [5].

## Design of slotted nozzles for transonic Mach numbers

The experience collected when using the nozzle described above led to an effort to calculate the necessary width of the slots. The following 9 steps summarize the design procedure of the slots in the supersonic part of the transonic nozzle:

1. Specify supersonic Mach number curve on nozzle axis from nozzle throat ( $x = 0, Ma = 1$ ) to some distance upstream of nozzle exit ( $x = l_e, Ma = Ma_e$ ).
2. Compute an estimate of the Mach number at the nozzle wall by stretching the prescribed Mach number curve on axis in such a way that the inclination of the characteristics is taken into consideration.
3. Calculate the flow rate  $\rho w$  on the axis and at the wall from the Mach number distribution.
4. The design mass flow  $\dot{m}_{design}$  in the nozzle as a function of  $x$  is calculated from the flow rates and the nozzle cross section.
5. Compute the local slot mass flow  $\Delta\dot{m}$  which has to leave the nozzle through the slots in order to achieve the design mass flow. This is done step by step, beginning at  $x = 0$ .
6. From  $\Delta\dot{m}$  an isentropic slot mass flow  $\Delta\dot{m}_{is}$  is calculated by guessing a discharge coefficient  $c_d$  and taking  $\Delta\dot{m}_{is} = \Delta\dot{m}/c_d$ .
7. For each location  $x$  an isentropic flow rate through the slot  $\rho w_{slot}$  is calculated from wall pressure inside the nozzle (this wall pressure can be deduced from the wall Mach number) and chamber pressure outside the nozzle.
8. Calculate from  $\Delta\dot{m}_{is}/\rho w_{slot}$  the required local slot area.
9. Calculate the local slot width and smooth it eventually.

In our case a quadratic polynomial was chosen as a Mach number curve on axis which starts with  $Ma = 1$  and ends horizontally at  $Ma = Ma_e$ .

$$Ma(x) = (1 - Ma_e)/l_e^2 \cdot x^2 + 2(Ma_e - 1)/l_e \cdot x + 1 \quad (1)$$

where  $l_e$  is the design length of the nozzle reduced by the stretching factor which is explained in the following.

The axisymmetric Mach number field in the supersonic part of the nozzle might be constructed by supersonic potential flow theory e.g. the method of characteristics, but it seemed to be sufficient to have a good guess of the wall pressure, as from this the frictionless flow through the slots can be computed. According to [6] the correct wall pressure prediction is especially important in

the rear part of the slotted nozzle where the prescribed Mach number approaches the desired outlet Mach number  $Ma_e$ . Therefore it was found sufficient to stretch the Mach number distribution on axis by the inclination of the characteristics to get the wall Mach number distribution, i.e. the Mach number at the wall is the same as the Mach number on axis, only the location at the wall is shifted by  $\delta x$ .

$$\delta x = \frac{d_e}{2} \cdot \sqrt{(Ma^2 - 1)} \quad (2)$$

This procedure doesn't change significantly the Mach number distribution close to the throat, but it should give correct wall pressures near the nozzle exit, if the flow in the nozzle is similar to a Laval nozzle flow — which is desirable.

A flow rate can be calculated from Mach number according to following equation:

$$\rho w = p_0 \cdot \sqrt{\frac{\kappa}{RT_0}} \cdot Ma \cdot \left(1 + \frac{\kappa - 1}{2} Ma^2\right)^{\frac{\kappa + 1}{2(1 - \kappa)}} \quad (3)$$

In the special case of step 7 the static wall pressure inside the nozzle is taken as total pressure and the slot flow Mach number is calculated from the ratio of chamber pressure (pressure outside the nozzle) to the wall pressure inside. Then these values are inserted into equation (3).

From the experimental investigation of the slotted nozzle designed for a Mach number  $Ma_e \approx 1.2$ , the slot discharge coefficient seems to lay around  $c_d = 0.9$  as the optimum Mach number of  $Ma_e \approx 1.27$  (figure 13) indicates. This depends of course on the ratio of slot width to depth. For our nozzle the slot depth is very small. In the case of slots having a much thicker wall the friction effects should be larger giving lower discharge coefficients. During the design process  $c_d$  was varied between 0.8 and 1.0 and  $c_d$  was deliberately lowered locally within the

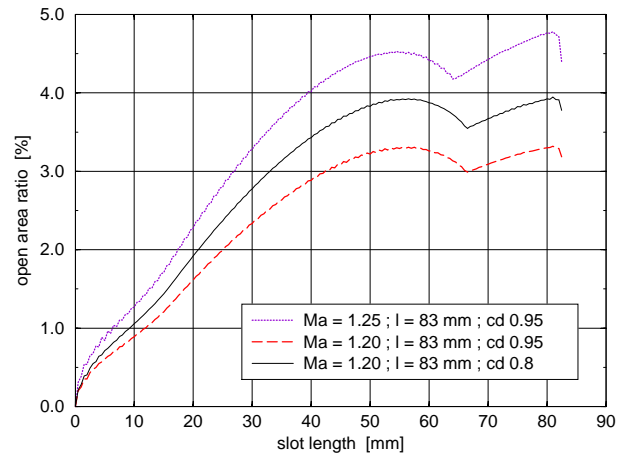

Figure 6: Open area ratio of slotted nozzle (total slot width to nozzle perimeter) for different design Mach numbers and discharge coefficients

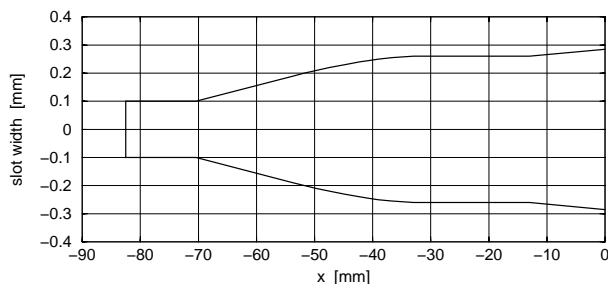

Figure 7: Actually manufactured slot: slot width of one slot is displayed as a function of the x-coordinate ( $x = 0$  at the nozzle exit)

first 10 mm behind the throat, because it was supposed that the very thin slots just behind the throat will indeed suffer from higher friction losses.

In figure 6 the output of the design method is shown for two Mach numbers and two discharge coefficients. The open area ratios depend not only on Mach number and discharge coefficients, but also on the design length of the nozzle's supersonic part, which was 83 mm in the present calculation. For the actually manufactured nozzle a curve resembling the middle one was chosen. As we inserted 12 slots into the cylindrical surface area of the nozzle, the calculated total slot width had to be divided by 12. The resulting slot width fell well below 0.2 mm at the beginning of the slot, a width we could not manufacture. Therefore a minimum slot width of 0.2 mm was set at the beginning of the slot; figure 7 shows the slot width of the manufactured nozzle. Accordingly it had to be expected that in spite of a design Mach number of 1.20 the actual nozzle would be better suited for a slightly higher Mach number. The experiments showed that it behaves best around  $Ma = 1.25$  (figure 13).

### 2.1.3 Supersonic nozzle design

To cover the supersonic range three Laval nozzles have been manufactured ( $d_e = 45\text{mm}$ ;  $Ma = 1.4, 1.5, 1.6$ ). The contour is designed using the method of characteristics and additionally corrected considering the boundary layer development according to 100 kPa stagnation pressure.

First measurements at  $Ma = 1.4$  showed that the nozzle works well [8] and also do the two others.

## 2.2 Wind tunnel control and data acquisition system

The wind tunnel is operated using the SIMATIC software by Siemens for flow control and the LabView software for both probe positioning and data acquisition; a sketch of the wind tunnel showing the connections of the software is given in figure 8. The SIMATIC software runs the compressor, the cooler, the valves for the bypass pipes, the valves to the vacuum pump and the connection to the supply of pressurized air. Values of

control are the prescribed Mach number, the total pressure and the total temperature. Variation of the latter is possible within a small range of about 295K up to 315K, only. The total temperature of the fluid is regulated by means of the amount of cold water passing the cooler. The total pressure is measured far upstream of the nozzle and regulated by means of the pressurized air supply or the vacuum pump. The Mach number at the nozzle's exit is calculated from the mean value of the static pressure taken at four circumferential positions and the total pressure.

The data acquisition is done by means of the LabVIEW software. This holds for the positioning of the probe head when either calibrating a probe or measuring the flow quality of the free jet as well as for collecting the probe's readings of the pressure taps.

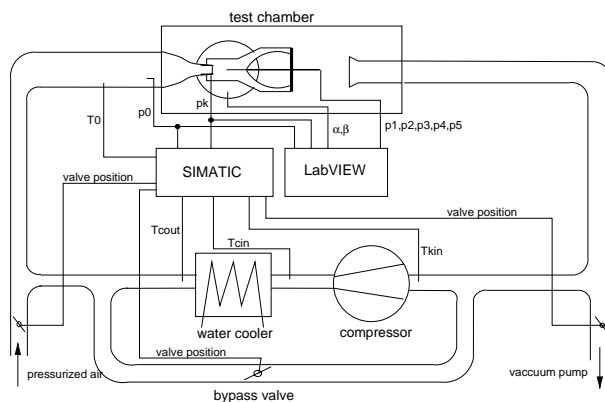

Figure 8: Flow control and data acquisition at SEG (schematic)

## 2.3 Measuring the flow quality

First of all it is necessary to get some information about the flow quality of the free jet downstream of the nozzles; additionally there is also some interest on the flow development inside the nozzle. For that reason a pitot probe and a static pressure probe were manufactured for measuring the total and the static pressure downstream of the nozzle to investigate the spatial behaviour of the free jet. A shaft probe is used to get the static pressure at the center line of the nozzle from far upstream of the throat to some distance downstream of the exit plane.

A 3-D traverse mechanism allows for moving these probes. The data input (next position) for the used stepping motors is given by the LabVIEW software. These values are recorded together with the pressure values by the LabVIEW program.

## 2.4 Calibrating a probe

Probe calibration has to be done within a Mach number range at different Reynolds numbers as well as considering an interval of flow angles (pitch and yaw angle). The Mach number range is limited by the pressure ra-

tio of the compressor (maximum value) and the mass flow through the bypass pipe (minimum value) at the different total pressures ranging from  $30kPa$  to  $290kPa$ . Figure 9 shows the possibilities for varying Mach number and Reynolds number (based on diameter  $d_e = 50mm$  and Mach number  $Ma_e$  at nozzle exit).

For turning the probe there is a range of  $\pm 22^\circ$  for the yaw angle and  $\pm 22^\circ$  for the pitch angle. The assembly keeps the probe tip at the centerline for all movements and allows for including the probe holder used in the wind tunnel into the calibration process.

The data input (positioning the probe) and data recording (taking the relevant wind tunnel data and the probe's readings) is done by the LabVIEW software, too.

First calibrations were done with a wedge type probe (2-D flow) and a pyramid probe (3-D flow) to be used in the wind tunnel for straight cascades at DLR Göttingen.

Flip over measurements yield for the deviation between the axis of the probe head and the axis of the shaft as well as for the deviation between the axis of the nozzle and the axis of the free jet (see [7]).

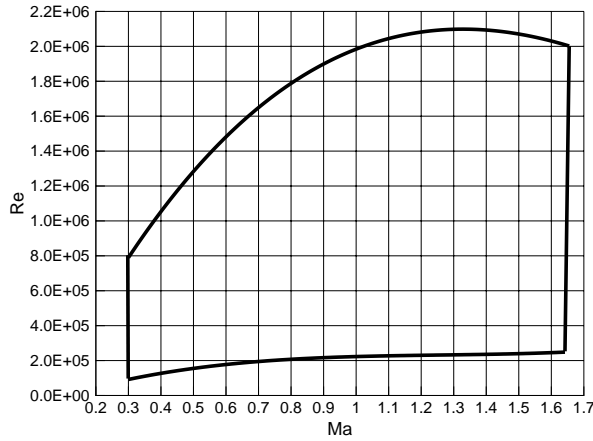

Figure 9: Range of Mach numbers and Reynolds numbers available for probe calibration up to now

### 3. Flow quality of the free jet

First of all measurements concerning the flow quality of the free jet and inside the nozzle were performed. Because of atmospheric inlet conditions of the EGG where most of the calibrated probes are to be used the stagnation pressure was set to  $p_0 = 100kPa$ . Total pressure as well as static pressure were measured downstream of the nozzle exit plane; additionally the static pressure at the center line of the nozzle was recorded.

#### Subsonic Flow

In case of the subsonic nozzle figure 10 indicates the development of the free jet downstream. Inside the free jet up to a distance of  $3 \times d_{ne}$  there is an area where

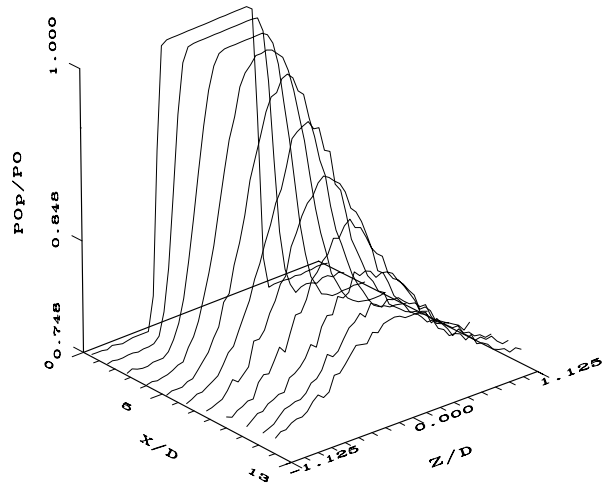

Figure 10: Total pressure of the free jet

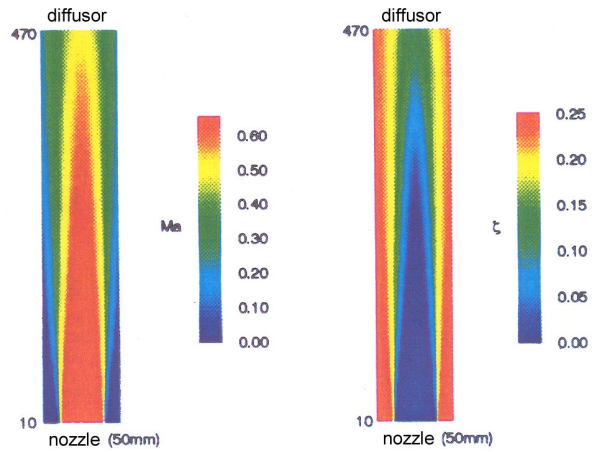

Figure 11: Local Mach number (left) and loss coefficient (right) of the free jet

$p_{0p} = p_0$  while proceeding downstream the total pressure decreases rapidly to the pressure inside of the test chamber. That is due to the free shear layer originating at the nozzle exit from the boundary layer inside the nozzle and the velocity difference inside and outside of the jet. The local Mach number of the free jet (figure 11) indicates an extended area (red color) of constant flow velocity. Therefore the flow field just downstream the nozzle exit plane is suitable for subsonic probe calibration. A diffuser insert (half cone angle of  $5^\circ$ ) serves for reducing the length of the free jet and so to reduce the overall loss, [3].

#### Transonic Flow

The total pressure just downstream of the nozzle exit plane (figure 12) is absolutely constant at  $p_{0p}/p_0 = 1.0$  and decreases rapidly within the shear layer down to the pressure in the test chamber.

The static pressures at the center line were taken by means of a shaft probe for several pressure values in the

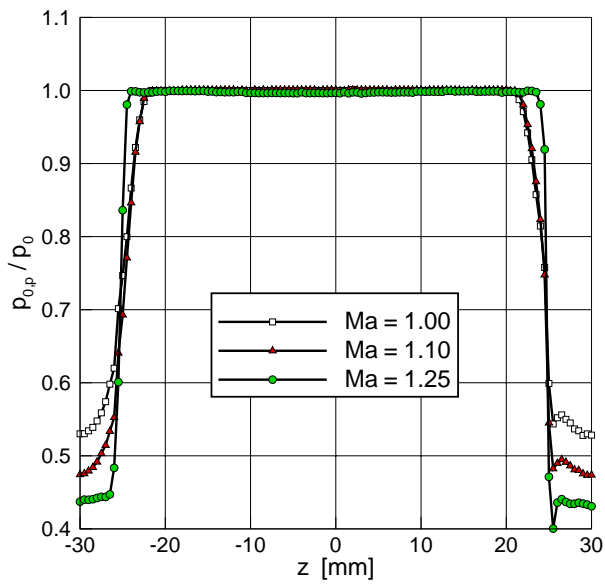

Figure 12: Total pressure downstream of the transonic nozzle ( $x = 2mm$ )

test chamber corresponding to different Mach numbers ranging from  $Ma_e = 0.95$  to  $Ma_e = 1.30$  (figure 13). There is a continuous acceleration of the fluid up to the throat independent of the exit Mach number. In case of  $Ma_e = 0.95$  and  $1.00$  the Mach number inside the slotted part  $Ma_e$  is reached at the very beginning and kept constant. In case of higher Mach numbers there is a small overexpansion caused by the slots, which are wider than necessary for the flow field because of manufacturing reasons (see figure 7); proceeding to the exit there is an area of constant Mach number near the exit plane in case of  $Ma_e = 1.27$  only - the design goal is achieved at that Mach number. Therefore at Mach numbers  $Ma_e = 1.05$ ,  $1.10$  and  $1.27$  the flow field is suitable for probe calibration.

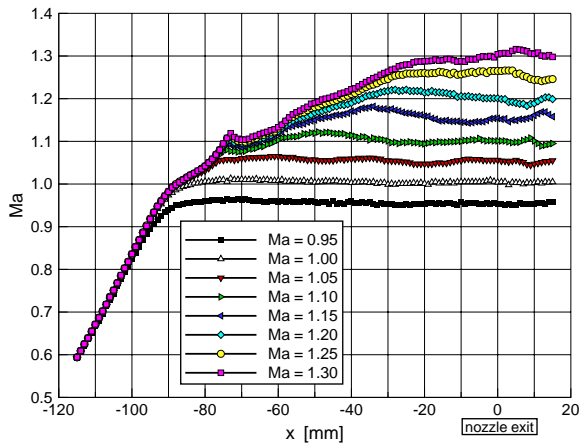

Figure 13: Mach numbers at the center line of the transonic nozzle

## Supersonic Flow

The supersonic flow field created by means of a Laval nozzle ( $Ma_e = 1.4$ ) was investigated. The total pressure downstream the nozzle exit (figure 14) indicates a homogeneous flow field inside the free jet, which is reduced further downstream because of the extension of the shear layer. The measured Mach numbers at the center line (figure 15) are just below the design value. That is due to the boundary layer inside the nozzle which is thicker than assumed for the correction of the contour. Downstream the exit (up to  $x = 10mm$ ) the Mach number still remains constant. Proceeding further downstream a small deceleration is to be seen because of compression waves from the beginning of the shear layer. Finally, an overexpansion of the static pressure is to be seen due to the chamber pressure being lower than the design exit pressure of the Laval nozzle.

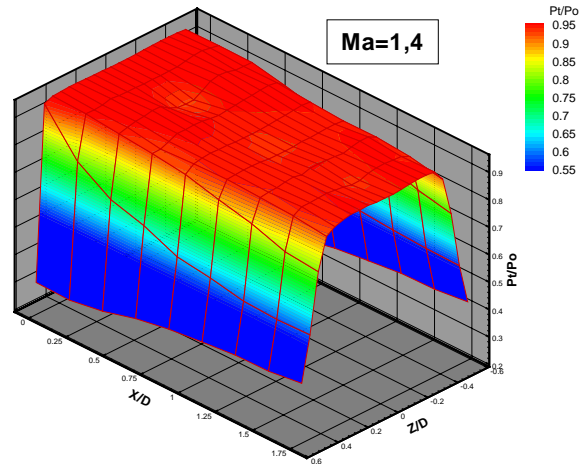

Figure 14: Total pressure downstream of the supersonic nozzle ( $Ma = 1.4$ )

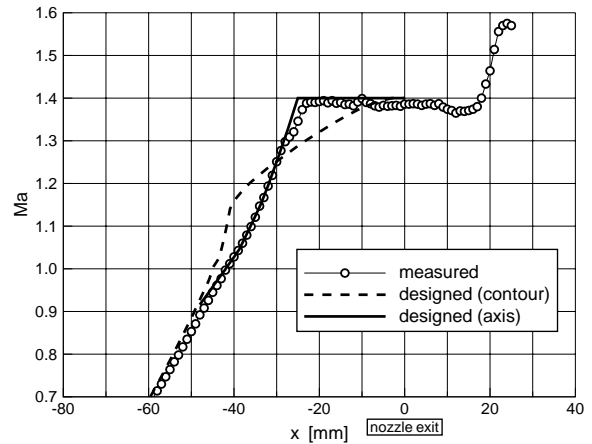

Figure 15: Mach numbers at the center line of the supersonic nozzle  $Ma = 1.4$

Summarizing the experiments concerning the flow quality of the different nozzles it is to be seen:

- The stagnation pressure varies at about  $\pm 0.2kPa$  due to the pressure regulation of the SIMATIC software and also does the total pressure downstream of the nozzle exit.
- The static pressure varies at about  $\pm 0.3kPa$  giving a Mach number uncertainty of  $\Delta Ma \approx \pm 0.005$  in case of supersonic flow.
- At subsonic flow conditions there is a higher accuracy ( $\Delta Ma \approx \pm 0.002$ ) of the predetermined flow values than at supersonic flow conditions.
- With the supersonic nozzles there is a regime of constant flow velocity downstream of the exit plane suitable for probe calibration.

That means the subsonic and the supersonic nozzles are well suited to hold for a homogeneous flow field just downstream of the exit plane. The flow field of the transonic nozzle is suitable at Mach numbers up to  $Ma_e \approx 1.1$  and for  $Ma_e = 1.27$ .

## 4. Some results of probe calibration

The first probe calibrated in the new wind tunnel was a pyramid probe for investigating 3-D flow fields in the wind tunnel for straight cascades at DLR, Göttingen. A sketch of the probe is shown in figure 16.

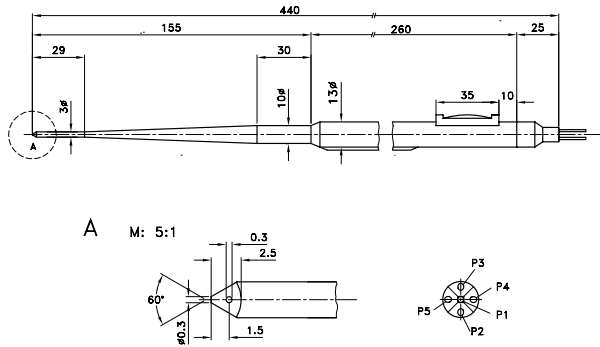

Figure 16: Sketch of the pyramid probe

Calibration of the pyramid probe is done using the procedure first presented in [9] and modified in [10] to be applied with a 5-hole probe. In figures 17 and 18 the three coefficients  $c_\alpha$ ,  $c_\beta$ ,  $c_{Ma}$  are shown for different Mach numbers.

Later on further probes were calibrated in the new wind tunnel, first a wedge type probe to be used for investigating 2-D flow fields and second another 5-hole probe to be used within 3-D flow fields. These experiments proved the flexibility when inserting different probes with different probe holders.

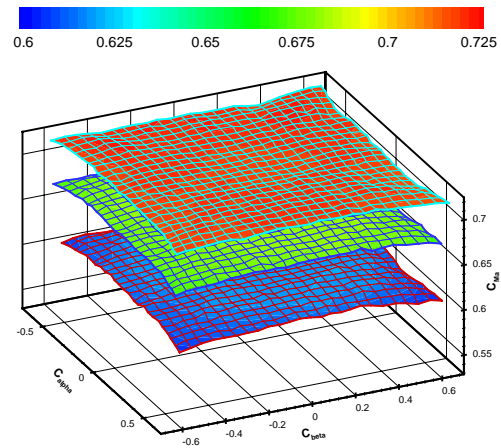

Figure 17: Measured coefficients at  $Ma = 0.7, 0.8, 0.9$

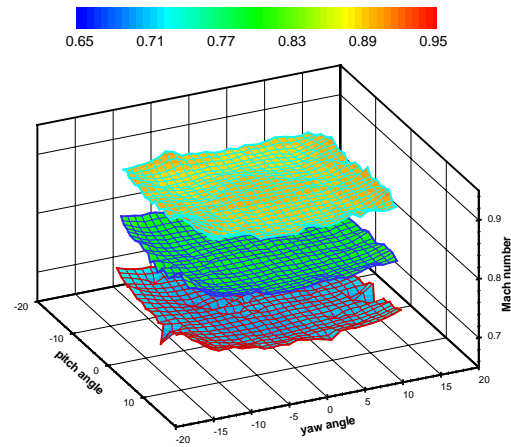

Figure 18: Calibration matrix

## 5. Summary

At DLR, Göttingen, a new wind tunnel for probe calibration was built, offering an independent variation of Mach number and Reynolds number. The flow field for calibrating probes is well suited at subsonic Mach numbers and at supersonic Mach numbers (when using Laval nozzles). Within the transonic regime a slotted nozzle holds for flow fields suitable at several discrete Mach numbers.

Because of the small diameter of the free jet probes up to a diameter of  $\approx 3mm$  can be calibrated.

Further activities should concern the improvement of the transonic nozzle and the manufacturing of a supersonic nozzle at a Mach number of  $\approx 1.8$ .

## References

- [1] Schmidt, V.  
Entwurf einer Meßstrecke zur Kalibrierung von Strömungs sonden

- [2] Börger, G.G.  
Optimierung von Windkanaldüsen für den Unterschallbereich  
ZFW 23, Heft 2 (1975)
- [3] Coulon, V.  
Experimental Study of the Free Jet in a Wind Tunnel for Probe Calibration SEG (Sondeneichkanal Göttingen)  
IB 223 - 96 A 58, DLR, Göttingen, 1996
- [4] Renner, M.; Stetter, H.; X.-S., C.  
Flow and Wetness Measurements at a Transonic Wind Tunnel with a Slotted Nozzle  
In Dvorak, R., Hrsg., *Measuring Techniques for Transonic and Supersonic Flow in Cascades and Turbomachines*, Proceedings of 12th Symposium, Sept. 14th-15th, 1994, S. 23/1 – 23/8, Prague, 1994, Czech Academy of Science, Institute of Thermodynamics
- [5] Haberkorn, M.  
Strömungsfeldmessungen zur Überprüfung und zur Kalibration einer geschlitzten Transschalldüse  
IB 223 - 2000 A 01, DLR, Göttingen, 2000
- [6] Ramaswamy, M. A.; Cornette, E. S.  
Supersonic Flow Development in Slotted Wind tunnels  
AIAA-Journal, vol. 20 No. 6, AIAA, 1982
- [7] Tiedemann, M.  
Eichung von Keilsonden und deren Anwendung zur Bestimmung von Strömungsgrößen aus Gitternachlaufmessungen  
IB 223 - 95 A 14, DLR, Göttingen, 1995
- [8] Champommier, J.  
Detaillierte Strömungsfelduntersuchungen in zwei Lavaldüsen mit Kalibration einer Fünf-Loch-Pyramidensonde im supersonischen Strömungsfeld  
IB 223 - 99 A 02, DLR, Göttingen, 1999
- [9] Main, A.; Day, C.; Lock, G.; Oldfield, L.; Rose, M.  
Calibration of a Four-Hole Pyramide Probe for Loss Measurement in a Transonic Cascade Tunnel  
In Dvorak, R., Hrsg., *Measuring Techniques for Transonic and Supersonic Flow in Cascades and Turbomachines*, Proceedings of 12th Symposium, Sept. 14th-15th, 1994, S. 20/1 – 20/8, Prague, 1994, Czech Academy of Science, Institute of Thermodynamics
- [10] Fetzner, B.; Gieß, P.-A.  
Kalibration einer Fünf-Loch-Pyramidensonde in subsonischer Strömung  
IB 223 - 98 A 01, DLR, Göttingen, 1998