

TECHNOLOGY AND DESIGN DEVELOPMENT FOR A CFRP FUSELAGE

DR.-ING. LARS HERBECK, HOLGER WILMES, DR.-ING. BORIS KOLESNIKOV AND
MARKUS KLEINEBERG

German Aerospace Center, Lilienthalplatz 7, 38108 Braunschweig, Germany,
lars.herbeck@dlr.de

SUMMARY

The project "Black Fuselage" of the German Aerospace Center DLR in cooperation with the Forschungszentrum Karlsruhe ("black"= black color of the carbon fiber) will further develop the competence of the aircraft design capabilities. The main objective is the reduction of the manufacturing costs by 40% of today's metal-constructed fuselage until 2010.

With a fiber reinforced design the fuselage weight of a commercial standard body aircraft can be reduced by 30%. Additionally, Carbon Fiber Reinforcement Plastic (CFRP) needs less maintenance compared to common metal-alloys. Also comfort and crash security, higher fire-resistance and life expectancy will increase.

The object of this paper is the technological background, the essential steps of the production process and the experiences made during manufacture of large foam core sandwich Panels for the CFRP fuselage demonstrator manufactured in a Liquid Resin Infusion Technology.

The results of this work were displayed by a full-scale demonstrator that was presented to the public for the first time at the ILA 2002 International Aerospace Exhibition in Berlin (see Figure 7).

1 INTRODUCTION

A few decades ago, it was hard to foresee the present degree of traffic volume in aviation. An increase of up to 5% per year is estimated which will mean twice the amount of the present traffic volume in aviation in the next few years as a consequence. As a result of this increase, the focal point in aviation research has changed: Socio-economic aspects are coming to the fore. The reduction of emissions such as noise and pollutants is becoming more significant. In particular, the reduction of the weight of the structure of future aircraft is a central task that will enable a reduction of fuel consumption and an increase in the payload.

The international competitive situation and the related increase in global competition in the air-craft industry is additionally making it necessary to considerably reduce costs in the development, production, and maintenance of the next generation of aircraft. The development time must be considerably shortened in order to enter aircraft faster into service.

In addition to weight and cost, additional challenges in the future will be increased safety requirements for aircraft in the case of accidents, etc. Improvements in these areas are indispensable in order to ensure a high acceptance of this means of transportation in the future.

1.1 Technological Approaches in Aviation

Considerable technological efforts are necessary to realize the requirements for weight and cost reductions and for an increase in the safety of future structures.

Development and research topics in the area of conventional metal materials [1] range from improvements of the material to more economical manufacturing methods: advanced materials and alloys (aluminum 2524, aluminum lithium, Glare ®), the commissioning of improved automatic riveting machines, the use of new assembly technologies (friction stir, laser beam welding) and improved manufacturing technologies (the extrusion of complex aluminum structures). The concepts of today figure in a reduction of costs - up to around 10-20% depending on the technology. In addition, a reduction in weight in the range of about 10-20% is considered realistic. However, both economical advantages and mass reduction for these different areas are not always feasible.

Medium to long-term conceptions in the aviation industry require a reduction in manufacturing costs of approx. 40% and a reduction in mass of about 30% for important structural elements in comparison with today's components. These goals can only be realized with technological advancement. And the best means of achieving this is with composite technology.

Composite materials are used today for different types of components. Present potentials as well as conceptual degrees of freedom as compared with metal have not yet been exhausted in the structures that have been realized up to now. In addition, the use of carbon fiber-reinforced plastics (CFRP) has a promising number of additional advantages compared to similar structures made of metal: a decrease in maintenance due to fatigue, an increase in comfort, greater crash safety, and improved burn-through safety.

However, these aspects make it necessary to adapt the design concepts which, in contrast to a 1:1 substitution of the aluminum construction, first and foremost have to take into consideration the characteristics of the composite.

In the long term, a change in the aircraft configuration will become necessary in order to enable additional savings. The "flying wing" that is already being used in military aviation is certainly an option with regard to cost and weight. But this also requires materials that allow for such structures to be produced at an optimal weight and cost. The use of composite technology will therefore play a key role not only here but also in other areas, making it the material of the future.

1.2 HGF Project: "Black Fuselage"

The airplane configuration that has been used for decades consists of a weight distribution of 40% for the wing and approx. 45% for the fuselage. The manufacturing costs for both of these large structures are about in the same range.

Taking a typical standard body aircraft as an example, an approximately 30% reduction in the mass of the fuselage of future aircraft would result in the reduction of about 3-4 tons and would mean a fuel savings about 14 million litres of kerosene during the aircraft's life-span.

An essential part of the „Black Fuselage“ project was the development of a new design concept that is appropriate for the composite, that makes optimal use of the potential of advanced composite components and that provides answers on specific issues that come up in the new concepts for aircraft structures. Different design concepts (e.g. the Gondola concept, the Lampassen concept [2], [3], [4], [5]) were worked out that take aspects into consideration such as crash, impact, notch sensitivity of the material while including an additional multifunctionality of the structure.

In order to reach the economical goals that had been made, manufacturing concepts and ideas based on proposed construction concepts were developed with the goal of an integral production of advanced composite components. A main task was a considerable

reduction of the present manufacturing costs as compared with aluminium fuselages. A consistent resin injection technology for CFRP composites was further developed and the possibilities of the using textile technology for dry semi-finished products (preform technique, stitching technique, etc.) were examined. The manufacturing concepts were supplemented with the development of new joining methods for advanced composites. See Proceedings: Workshop „Schwarzer Rumpf“ [6] for additional information.

2 CFRP FUSELAGE DESIGN CONCEPTS

The requirements for a fuselage made of advanced composite are basically not much different than those for a conventional fuselage made of aluminum. The following structural mechanical loads have to be taken into consideration:

- Forces that are introduced through the assembly attached to the fuselage (wings, empennage, landing gear),
- inertia forces of components, loads, and equipment that are stowed in the fuselage (including landing impact, etc.)
- mass forces of the fuselage construction,
- air forces that run over the surface of the fuselage and
- forces that are the result of the difference between the pressure on the inside of the fuselage and its surroundings.

In addition to the above loads, crashes and impacts due to hail, blows from stones, area debris, as well as fire must be taken into consideration in the design. In addition, in-service aspects, comfort, and compatibility must be taken into consideration in an aircraft. This large number of requirements calls for a multifunctional construction.

2.1 Remark on the reference structure

The entire fuselage including the cargo compartment of a standard body aircraft is loaded with inner pressure. The supporting pressure-ventilated lower panel contains large cut-outs for the nose gear bay, for different cargo doors and for the landing-gear well, which is located in the area of the greatest bending moments.

The big cut-outs greatly disturb the flow of forces that result from the bending stress. In addition, the even frames and panels loaded with inner pressure do not represent an optimal lightweight fuselage construction from a structural mechanics point of view.

The constructive designs of the above-mentioned cut-outs (especially those in the pressure-ventilated floor with pendulum and membrane areas) are very complicated and result in high manufacturing costs.

2.2 Gondola concept – CFRP fuselage construction with a pronounced “sacrificial” structure

The presented design concept for an aircraft of the next generation is characterized by the fact that the aluminum material is completely replaced by CFRP. The passenger area is designed as the **primary structure** and the entire **cargo compartment** and with that the sub floor area is constructed as the secondary structure. In addition, the cargo compartment is not hermetically sealed and therefore is not loaded with inner pressure.

2.2.1 Primary structure (passenger area)

The passenger area is built with two side shells and a floor structure with circular skins that form a highly-integrated structure (Figure 1).

The skin of the floor structure is approximately twice the radius compared to the skins of the side shells. The level of the floor slab runs through the intersection point of the upper

and lower circular skins, which is ideal. This floor slab arrangement and the circular shells cause minimal bending loads due to inner pressure. The floor slabs and seat rails of the floor structures are bearing load in the Gondola Concept and, in view of the entire loading, take on the appropriate load level.

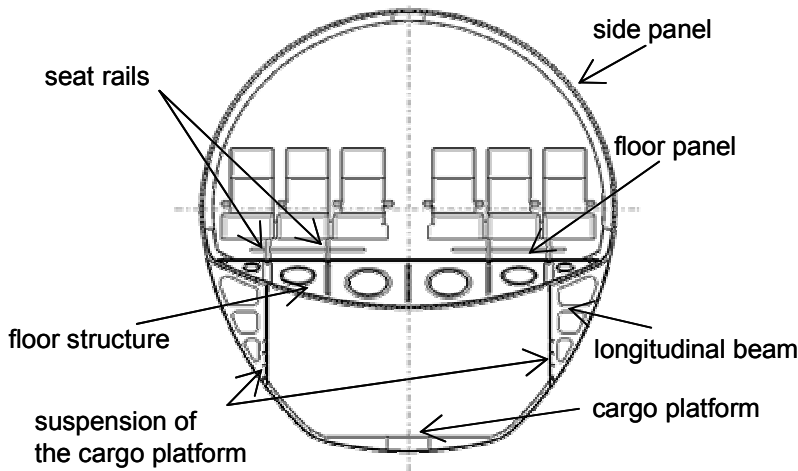

Figure 1: Cross-section of the CFRP fuselage built according to the Gondola concept

2.2.2 Secondary structure (cargo compartment)

The cargo compartment consists of a cargo platform that is suspended and fastened to the floor structure (Figure 1). The platforms and the paneling elements are separated from each other in the longitudinal direction so that they do not affect the entire load-bearing behavior. They can ideally be made as modules and, with such an exchange, an adaptation of the cargo compartment to different transportation assignments is possible.

Therefore it is possible to use different cargo compartment cross-sections depending the type of transportation.

Because the cargo compartment is a secondary structure, only the inertia forces of the cargo as well as safety requirements with regard to impact and crash are dimensioned. Because the cargo compartment is not pressure ventilated, requirements for the tightness of the cargo doors and therefore their stiffness are reduced. In addition, much less effort is required to reinforce the cut-outs since the cargo compartment is a secondary structure.

2.2.3 Shell concepts

Different criteria were decisive in the assembly of the shells: An uncomplicated and economical manufacture were very important as well as particular consideration of the impact load. The use of different materials was tested but the stipulation for a greater fire resistance was also decisive in the choice of material. Great importance was attached to profoundly integrated structure in order to reduce costs.

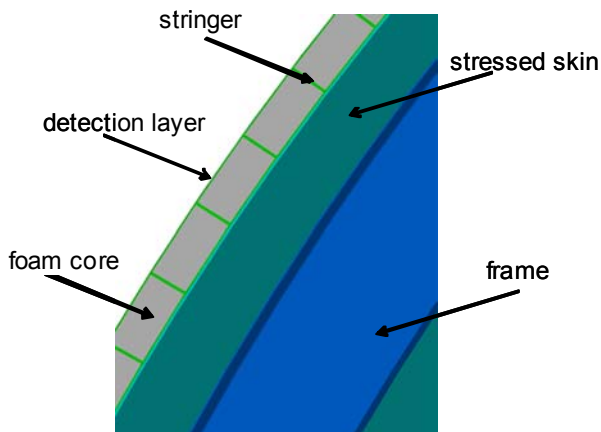

Figure 2: Set up of the shells: local separation of the stiffening elements

During the assembly of the shells in the passenger area, a single-shell construction with stringers and frames was preferred. One particularity is the local separation of both stiffening elements since the stringers are located outside of the skin and the frames are on the inside and between the skin. The advantage of this is that the cross-over points of the stringers and frames can be entirely avoided with this arrangement (see Figure 2). This also completely eliminates

the need to use clips (connecting elements between the skins and frame used in today's metal design).

The stringers can stand up perpendicular to the skin (see Figure 2) or at any angle (inclined webs). Because of the chosen set-up, the inner frame has many degrees of freedom. LZ or omega frames are also possible here as well.

An additional characteristic is the effort made to protect the skin from external impacts (e.g. hail). A foam-core and an exterior detection layer is put on the stressed skin so that it has a 1 ½ shell design.

The detection layer takes on the task of an aerodynamic surface and serves as an impact indicator. This construction can considerably reduce maintenance efforts. An optical examination is sufficient for large surfaces and only local, clearly identifiable areas require a more close examination.

The foam has multifunctional tasks since it acts as both a heat and noise insulator. It also supports the stringer against local buckling and serves as an aid during manufacture. However, demands on the foam, particularly during manufacture, are relatively high. As a result, only those that perform well with regard to temperature resistance and compression strength come into question.

A sandwich shell design comprising a hybrid core was selected in the cargo compartment taking especially into account high impact and burn-through resistance.

3 CFRP FUSELAGE DEMONSTRATOR

In order to demonstrate the insights that had been obtained, a full-scale structure was manufactured with which the different results and ideas could be demonstrated (Figure 3).

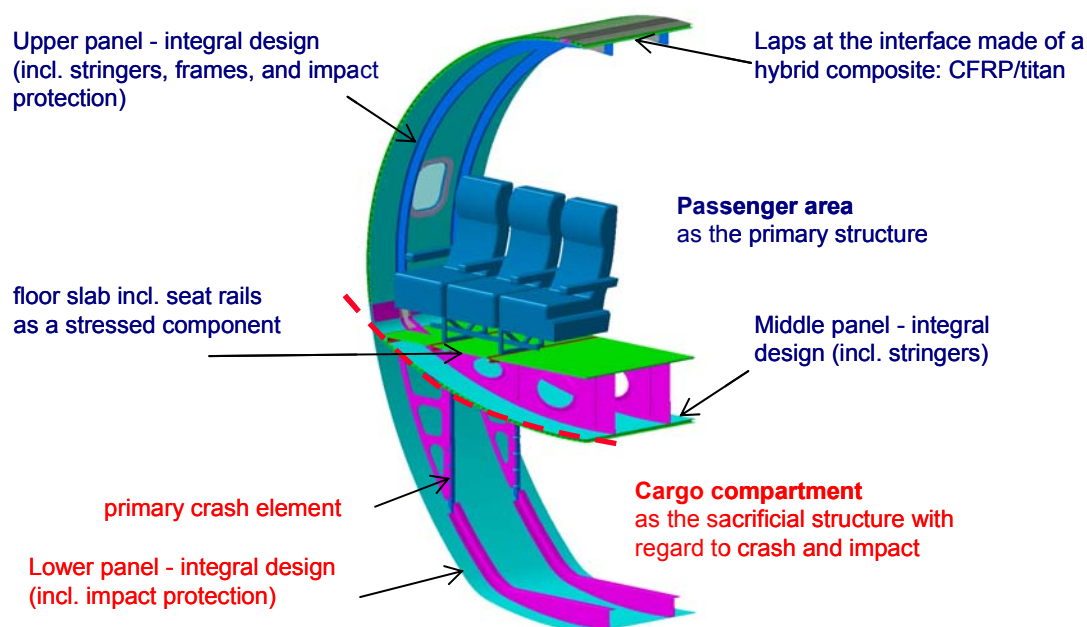

Figure 3: CFRP fuselage demonstrator

Original measurements were used in order to counter any doubts that such a structure could not be used in practice. But precisely the high degree of integration can only be clearly demonstrated by using such large structures. The goal was the manufacture of a half fuselage section (approx. 180°) with the length of one meter.

3.1 Design

The design that was chosen for the demonstrator is based on the Gondola concept. The demonstrator is divided into a primary and a secondary structure.

3.2 Manufacturing concept

The manufacturing concept was developed in such a manner that it could be used for a comparable series production later on. A concept for the manufacture of the shells was developed with the goal of cost-effectively fulfilling the design requirements. The single-line injection (SLI, see Figure 4) method [7] was used to manufacture the primary structure (passenger area). Specially formed stainless steel plates were used for the stiff toolings that represent the aerodynamic surface (see Figure 5).

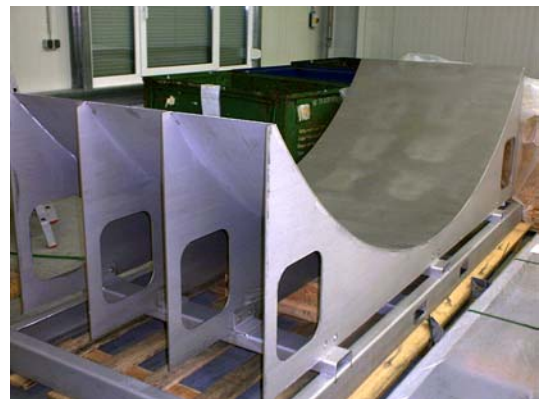
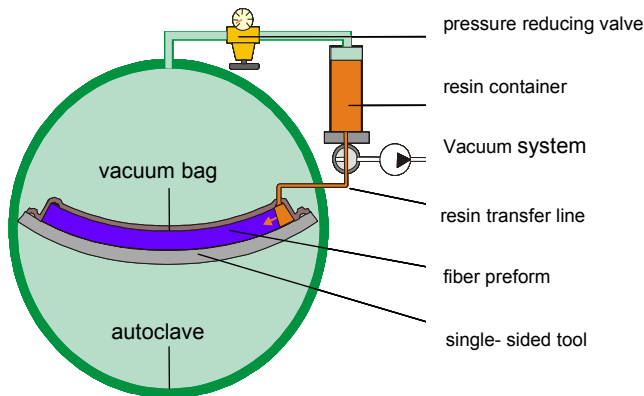

Figure 4: Single-line injection principle (SLI)

Figure 5: Tooling for the fuselage shells

Many of the ideas that were realized came about during the development of the design concept. The detector layer was composed of only one CFRP fabric layer and was directly placed on the attached tooling in order to achieve a good surface quality of the aerodynamic surface.

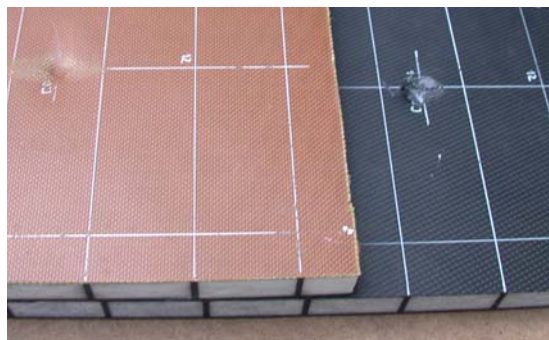

Figure 6: Comparison of two impacted shells with different detector layer materials

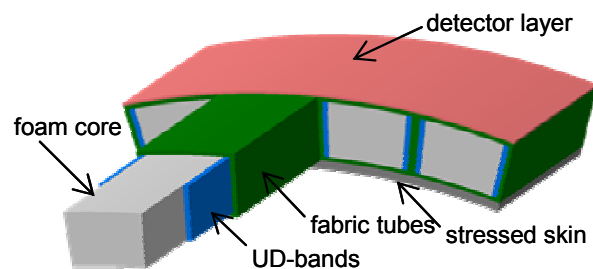

Figure 7: Set up of the shells

In order to attain a higher resistance against impacts, synthetic fibers such as Aramid or Zylon (PBO) were also tested for the detector layer. Production studies with a similar composition and a PBO layer have shown that this can definitely be an option. Even significantly better results were achieved at impact load with the synthetic fiber layer (see Figure 6). The foam was used as a production aid. It enabled a very easy set up of the shells (detector layer, stringer, foam, stressed skin and frames) in one step (see Figure 7).

The stringers were displayed by wrapping the closed-pored PMI foam [8] with dry carbon fiber tubes and bands [9], [10] according to the stiffness requirements. These were then

placed next to each other, fixed within the limit stops and compressed. The foam can be mechanically processed according to the requirements or formed with heat. The foam-manufacturer is currently working on an improvement of the foam with regard to processing using the liquid resin infusion (LRI) method. One of the goals, for example, is to improve the absorption of resin at the open-pored edges. The skin is laid on the wrapped tubes. A warp-knitted fabric [11] is used. Differences in the thickness of the skin were achieved in the area of maximum bending stress by applying thinner foam cores. This step is necessary to be able to apply the frame over the whole area with a constant bending.

The frame is carried out as a LZ frame. An aluminum tooling was used to display the contours. A possible alternative would have been the use of an Omega frame where a foam tooling is used, similar to the set up of the stringer.

This type of shell for the passenger area runs about 120° of the breadth and can be manufactured at almost any length. Because of the breadth of approximately 4 meters for the present non-crimped fabric widths, however, an adjoining or overlapping of the stacks is inevitable.

In contrast to the primary structure, the cargo compartment shell was manufactured using the vacuum-assisted resin infusion (VARI) process [12]. The panel consists of a sandwich with a hybrid core comprising 50% thickness of highly fire resistant PEI foam [13] at the outside, and 50% core thickness of Nomex honeycomb [14] at the inside. In the outer CFRF face sheet, a PBO-fabric impact “catching” and burn through protection layer was integrated. Different constructive measures for the absorption of energy in the case of a crash were carried out: integrated crash tube in cargo compartment strut, tension band and “plastic” hinges to reduce forces in y direction and to absorb additional energy.

3.3 Interfaces

In accordance with the design concept, three longitudinal joints were planned for the breadth. Mechanically joints were used for this purpose. CFRP/ titan composites were used to introduce additional stiffness and to reduce the weight of these interfaces. This hybrid is characterized by a high specific joining grade for bolted connections and additionally shows an extremely high degree of stiffness ([15], [16]) which is very useful in view of the reduced cross-section.



Figure 8: Demonstrator on ILA 2002 in Berlin

The interface of the upper shells with the floor structure also serves as a connection to the cargo compartment. An additional connecting point of the cargo compartment to the primary structure are the frame and crash tube that are connected to the floor structure.

The demonstrator was assembled in Brunswick and set in a frame see figure 8. It has been made big enough so that a person can walk around in it. The demonstrator is supplemented with a lattice structure shell that was manufactured by the CRISM (Crim Cat) Russian institute [17] using the filament winding method.

4 OUTLOOK

A number of questions concerning complex problems of the aircraft fuselage could addressed only marginally or not at all. A "typical" fuselage was primarily regarded here. Many detail problems and questions that came up even during the project had to be set aside and are only part of further work which will follow this project.

REFERENCES

- [1] Poston, Ken: Advanced Manufacturing and assembly technologies for future aircraft fuselage structures, Bombardiers Aerospace, Aerospace – A 2020 Vision, Royal Society, 2002
- [2] Kolesnikov B., Herrmann A. S.: Flugzeug, insbesondere Passagierflugzeug, mit einem Rumpf, der eine tragende Primärstruktur und einen Frachtraum umfasst, DLR Braunschweig, Patentanmeldung Nr. 10145276 von 14.09.2001.
- [3] Kolesnikov B., Herrmann A. S.: Flugzeug, insbesondere Passagierflugzeug, mit einem auf der Basis von Faserverbundbauteilen aufgebauten Rumpf, DLR Braunschweig, Patentanmeldung Nr. 101 45 272 von 14.09.2001.
- [4] Herrmann A. S., Kolesnikov B., Pabsch A., Piening M., Konzepte für CFK-Rumpfbauweisen zukünftiger Passagierflugzeuge, DLR Braunschweig, Tagungsband der DGLR-Jahrestagung 2001, Hamburg, 17.-20. September 2001.
- [5] Wilmes H., Kleineberg M., Kolesnikov B., Wenner U., Hanke M., Barth E., Fink A., "Schwarzer Rumpf" - Technologie- und Bauweisenentwicklung für einen CFK-Rumpf, DLR Braunschweig, Tagungsband der DGLR-Jahrestagung 2002, Stuttgart, 23.-26. September 2002.
- [6] Wilmes, H.; Herbeck, L. (Hrsg.): Proceedings: Workshop „Schwarzer Rumpf“ CFRP for Future Aircraft Fuselage Structures. Braunschweig, October 2002.
- [7] Herbeck, L.; Kleineberg, M.; Schöppinger, C.: SLI-RTM Nose Landing Gear doors for the Fairchild Dornier 728. 5. AVK-TV Tagung 2002, Baden-Baden, 2002
- [8] Fa. Degussa, Röhm Performance Plastics, Kirschenallee; D-64293 Darmstadt
- [9] Fa. J.H. vom Baur Sohn GmbH & Co. KG, Marktstraße 34, D-42369 Wuppertal
- [10] Fa. Siltex, Palmstraße 27, D-84387 Julbach
- [11] Fa. Saertex Wagener GmbH & Co. KG, Brochterbecker Damm 52, D-48369 Saerbeck
- [12] Feiler, M.: VARI- kostengünstiges Verfahren zur Herstellung von großflächigen Luftfahrtbauteilen, DLR Stuttgart, Tagungsband der DGLR-Jahrestagung 2001, Hamburg, 17.-20. September 2001.
- [13] Airex Corporation Route 108 Dover, NH 03820
- [14] Hexcel Composites, Duxford, UK; Dublin, CA USA
- [15] Kolesnikov B., Trennstellenproblematik und experimentelle Untersuchungen von CFK-Titan-Laminaten, IB 131-99-66, DLR Braunschweig, Dezember 1999
- [16] H. Wilmes, B. Kolesnikov „CFK / Titan, ein Hybrid-Werkstoff zur verbesserten Kopplung von Faserverbundstrukturen“, Congress „Intelligente Leichtbau Systeme“, Dornier Hannover, 13.-14. November 2002.
- [17] Barynin W. A., Bunakow W. A., Vasiliev V. V., Razin A. F. "Aerokosmische Netzkonstruktionen aus Faserverbunden" (in russisch), Poljot, Nr. 1, S. 40-43, Technische Universität für Flugwesen, Moskau, 1998.