

Overview of smart-structures technology at the German Aerospace Center

By Hans Peter Monner & Peter Wierach, German Aerospace Center (DLR), Institute of Composite Structures and Adaptive Systems

SYNOPSIS

Within the Institute of Composite Structures and Adaptive Systems of the German Aerospace Center the department of Adaptronics was installed in 1993. It is the largest group of scientists to work on adaptive structural systems in Germany. The main goals are

- active noise control,
- active vibration control,
- active shape control.

The department is strongly committed to national projects like ADVANCED AIRCRAFT STRUCTURES (DLR Project), LEITPROJEKT ADAPTRONIK (BMBF Project), ADAPTIVE PARALLEL ROBOTICS (DFG-Project) and international Projects like FRIENDCOPTER (EU IP), INMAR (EU IP), ARTIMA (EU STREP), ELECTRO ACTIVE POLYMERS (ESA). This involves the investigation of many aspects of smart structures including materials characterisation, development and design of actuators and sensors, structural integration of smart elements, and development of advanced control concepts as well as simulation and modelling of adaptive systems. This paper gives an overview of some of the department's activities within this field.

1. INTRODUCTION

A smart structure involves five key elements: structural material, distributed actuators and sensors, control strategies, and power conditioning electronics. With these components a smart structure has the capability to respond to changing environmental and operational conditions (such as vibrations and shape change). Microprocessors analyze the responses of the sensors and use integrated control algorithms to command the actuators to apply localized strains/displacements/damping to alter the elasto-mechanical system response. Actuators and sensors are highly integrated into the structure by surface bonding or embedding without causing any significant changes in the mass or structural stiffness of the system.

Smart-structures technology is a highly interdisciplinary field where associated methodology and technology still is in an early development. After a 'hype' phase with a peak probably beginning of the nineties with very unrealistic expectations one now has a pretty clear picture of the potentials and limitations of smart-structures technology. This is also the main reason why now numerous applications of smart-structures technology are continuously evolving to actively control vibrations, noise, and deformations. Applications range from space systems to fixed-wing and rotary-wing aircraft, automotive, optical systems, machine tools, medical systems, and infrastructure.

2. MAJOR ACTIVITIES

2.1 Leitprojekt Adaptronik

In 1997 the BMBF (German Ministry of Education and Research) announced a highly paid competition for future oriented key technologies and their industrial utilization. 230 proposals from industrial enterprises and research establishments were submitted. An independent group of experts selected altogether only 5 projects which were proposed to the BMBF. One of these major projects was the 'Leitprojekt Adaptronik' which was funded from 1998 to 2002 with a total volume of 25 000 000 € This project was under the direction of the DLR (German Aerospace Center) and focused on the integration of piezoelectric fibres and plates into lightweight structures aiming at active vibration and noise reduction, shape control and micro positioning. The main project target was the implementation of this technology in different industrial branches like the automotive industry, rail technology, mechanical engineering, medical engineering, and aerospace technology.

The project followed the strategy of establishing a synergetic network between the advanced scientific potential and industrial partners from the various branches with the aim of preparing a new generation of products with properties that are unique on the international scale. In this process the small and medium-sized companies played a key role as technological centres. To accomplish this ambitious task a network of industrial and research partners was established which purposefully combines and manages the individual disciplines of the highly complex field of smart-structures technology (see Fig. 1).

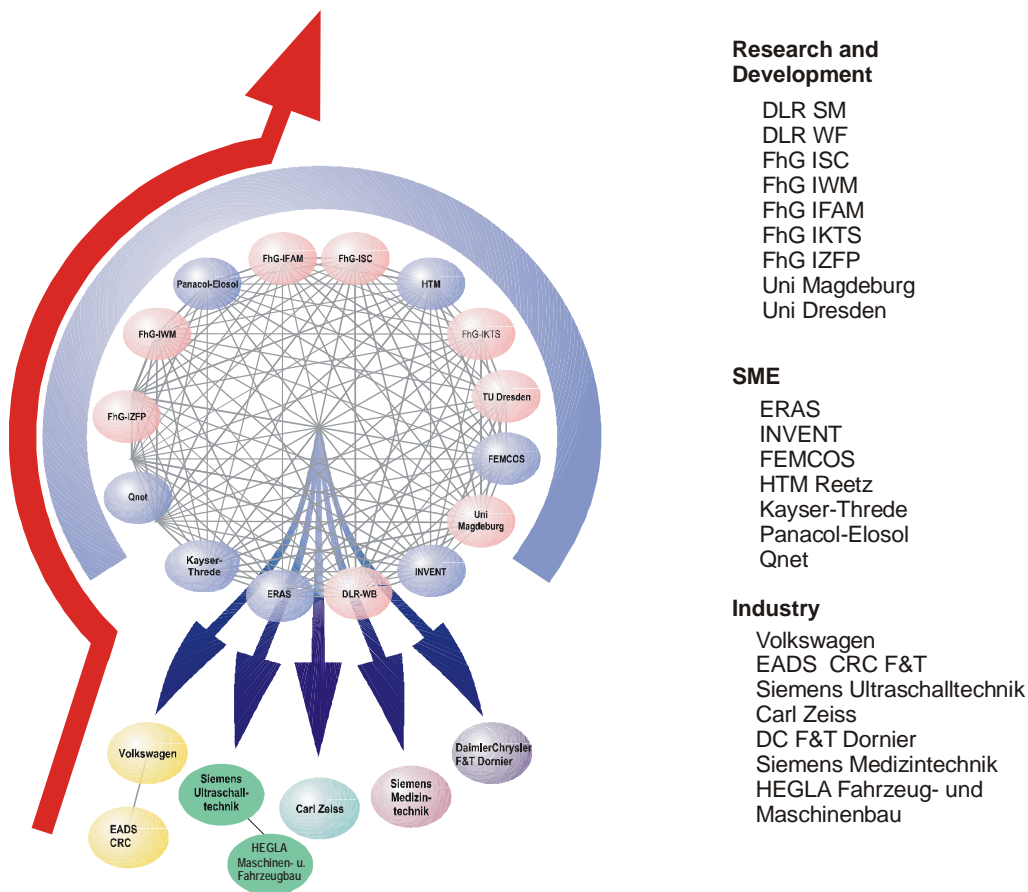

Fig. 1: Network of all partners involved

The industrial and research partners involved perform the required development work along the value added chain (material development → composite technology → adaptive overall system → prototype assemblies). This required parallel development work within the individual tasks. For this very complex and interdisciplinary approach, the establishment of synergies and exchange of results between the individual disciplines was absolutely essential. Most of the partners found themselves

within the various sections of the value-added chain. This reflects the complexity and interdisciplinarity as the individual sections of the value-added chain were closely interlinked and, necessarily, depended on each other. Aiming at noise and vibration reduction, contour deformation and stabilization, micro-positioning and Ultrasonic technology, the prototype assemblies were designed for use in the following branches of industry with their special targets [1, 2]:

- In traffic engineering piezoceramic patch actuators were used in passenger car construction to reduce vibrations caused by the roofing sheet, and in the rail car construction to achieve an active influence on the noise level inside the cabin by reducing vibrations in the boogie.
- The mechanical engineering focused on the active attenuation of machine vibrations to obtain a higher level of accuracy and new ultrasonic transducers with better cost to performance ratio.
- The optical industry developed a correction method for mirrors and deformation-free carriers of lenses, both for use in objectives for semiconductor lithography.
- In medical engineering adaptronic measures were implemented in order to give patients 'acoustic' relief in magneto resonance tomography (MRT).
- In the branch of aerospace the accuracy of antenna and satellite structures was achieved.

In 2001 the 'Leitprojekt Adaptronik' was awarded with the German research price of the sponsor association of the German research which demonstrates that the challenging approach starting from basic material development up to the implementation into industrial products could successfully be realised. In Germany the 'Leitprojekt Adaptronik' resulted in a significant increase of the popularity of smart-structures technology. Essentially every industrial branch is increasingly implementing smart-structures technology within their R&D departments and most of the technical universities are enhancing their engineering program of studies, respectively.

2.2 Patch actuators

The development of a new technology for the manufacturing of adaptive structures on the basis of piezoceramic materials was an important goal of the German 'Leitprojekt Adaptronik' described in section 2.1 [3]. Suitable multi functional material systems that combine load carrying, sensory and active properties are a vital prerequisite for the development of adaptive structures. The use of thin monolithic piezoceramic wafers as actuators and sensors for structural control has been discussed in many publications (e.g. [4], [5]). Piezoceramic wafers (thickness 100-200 μ m) are commercially approved and available in large numbers with constant quality. The research here is concentrated on the application specific design of the wafers regarding surface quality, geometry and electrode design. However, the manufacturing of these structures is still very demanding since the extreme brittleness of the piezoceramic material requires sophisticated manufacturing techniques to avoid damages. An appropriate solution for this problem is to encapsulate the brittle piezoceramic wafers before processing. With this step the piezoceramic is provided with a mechanical stabilization, electrical insulation and electrical contacts. Even though an additional manufacturing step is necessary the advantages predominate. Also the reduction of strain transfer due to the relative soft surrounding material can be considered as low.

With respect to the great variety of different requirements given by the industrial partners the use of standardised solutions was not feasible. The goal was to develop new elements with improved performance parameters that can easily be adapted to different applications. This requires the possibility to access every component of the encapsulated patch to enable a material specific selection of the components to get a compatible material system.

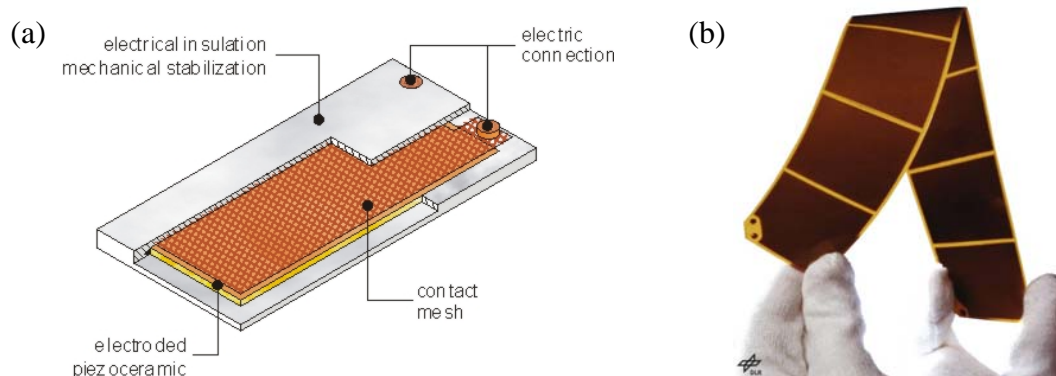

Fig. 2: (a) Principle design of encapsulated patch, (b) Special shaped actuator

Fig. 2 shows the principle design of the encapsulated patch as well as a special shaped actuator for a satellite mirror (see section 2.9). The piezoceramic wafers are provided with uniformly electroded surfaces to operate in the lateral d_{31} -mode. The piezoceramic is embedded between thin layers of insulating fiber material ($d < 0,05\text{mm}$) and layers with contacting structures. The contacting layer is made of a copper mesh (wire diameter 0.03mm) having the shape of the piezoceramic wafer. In case of a break the patch will still work because the contacting covers the whole electrode of the piezoceramic so that the broken pieces stay in the electrical field where they can be controlled. The materials and components of the encapsulated PZT-patches had been chosen and optimized with special regard to the integration into fiber composite structures but they can also be attached on any surface. Due to the adaptability of the manufacturing process it is possible to produce patches of nearly any shape. This is very interesting for circular or curved structures where hexagonal or curved patches are most suitable. These patches are presently being commercialised and will be manufactured and distributed by the INVENT GmbH, a spin-off company of the DLR.

The further development of piezoceramic patch actuators for adaptive structures is still an important research topic. By optimizing the electrode design and geometry in d_{33} actuators it is expected to reduce the voltage to achieve 0.1% active strain at $120\text{-}200\text{V}$. State of the art d_{33} actuators need voltages of more than 1500V to generate these active strain levels [6].

2.3 Carbon nanotubes actuators

A single walled carbon nanotube (SWNT) is a cylindrical shell built up of carbon atoms with a diameter as small as $1\text{ nm} - 100\text{ nm}$ and a length of up to 100 micrometers . It consists of pure carbon and can be pictorially described as a sheet of graphite that has been rolled into a tube (see Fig. 3).

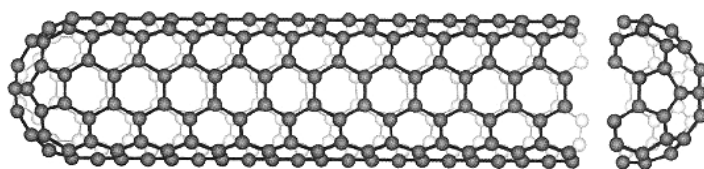

Fig. 3: Single walled carbon nanotube (SWNT)

SWNT have exceptional physical, mechanical and actuatoric [11] properties:

- Low density: $1,33\text{ g/cm}^3$ (aluminum alloy (F-50): $2,7\text{ g/cm}^3$)
- Density-normalized specific tensile strength and Young's modulus are, respectively, ~ 150 and ~ 19 times that of aluminium alloy (F-50)
- Active strain: 1% (piezoceramics: $0,1\%$)
- Driving voltage: 2 V (piezoceramics: 200V)

All these properties together result in solid state actuator capabilities far beyond anything known. E.g., the calculated energy density is ~ 700 times higher than the best values reported for piezoceramics! However, all these impressive properties are based on the full performance of the *single SWNT*.

Thus, the goal of our research activities is to achieve these properties of individual SWNTs also in macroscopic nanotube based actuator assemblies. As we proceed towards this goal several steps have to be taken.

At present the characterization of the actuation mechanism is the main focus of our work. For experimental investigations a special test rig was established, which allows to measure in plain strains of nanotube sheets (so called “Bucky-Paper”) in presence of liquid electrolytes. This allows to measure the static and dynamic system response, which is the prerequisite for a description of the system [12,13]. Also the influence of different parameters (e.g. type of nanotubes) can be investigated (see Fig. 4).

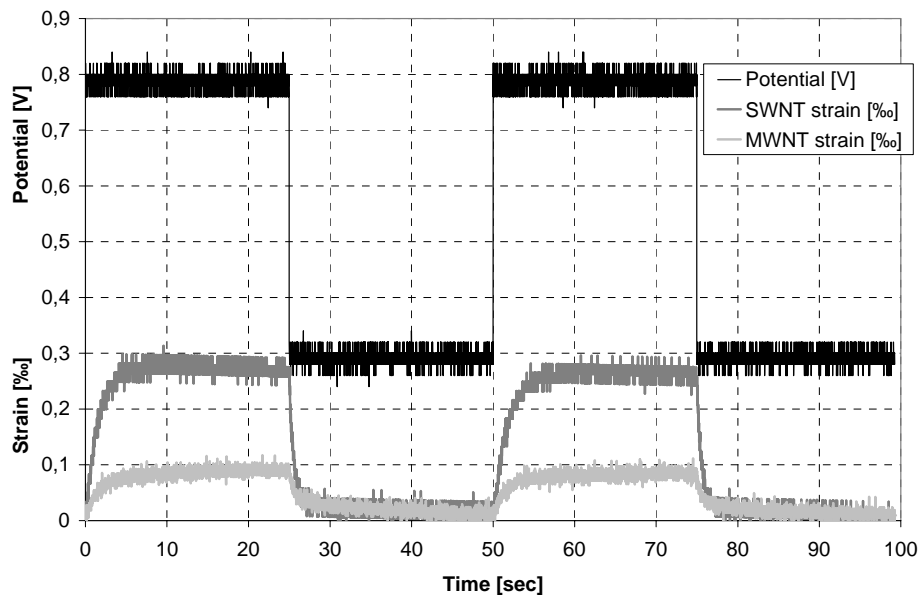

Fig. 4: System input (voltage step) and strain response for Single- and Multiwalled Nanotubes (SWNT/MWNT)

Key aspects of future activities will be: description of the electromechanical system, incorporation of solid state electrolytes, optimisation of system, substitution of Bucky-Paper by stronger CNT based structure (e.g. fiber...).

2.4 Adaptive car roof

A sound-radiating surface in a passenger car represents the roof, which is excited by engine oscillations among other things. If certain engine-harmonics match the resonant frequencies of the roof, unwanted noise can occur in the passenger interior, which impairs the comfort. One approach for avoiding this effect is the use of passive sound damping measures, which are partly well realized in modern vehicles. However, major disadvantages of these passive measures are that they don't really work in the low frequency band, that they're not able to adapt to changing operating conditions (e.g. temperature changes) and that they are connected with additional masses. Therefore, at the Institute of Composite Structures and Adaptive Systems active vibration reduction is pursued by means of adaptive components. The idea lies in the introduction of anti-oscillations, which contribute to a decrease of the roof oscillations and, thus, reduce the sound radiation. The work is accomplished at a Volkswagen Golf Mark 3 Estate series vehicle. Piezoelectric patches, developed and manufactured at the Institute of Composite Structures and Adaptive Systems, are used as sensors and actuators (see section 2.2).

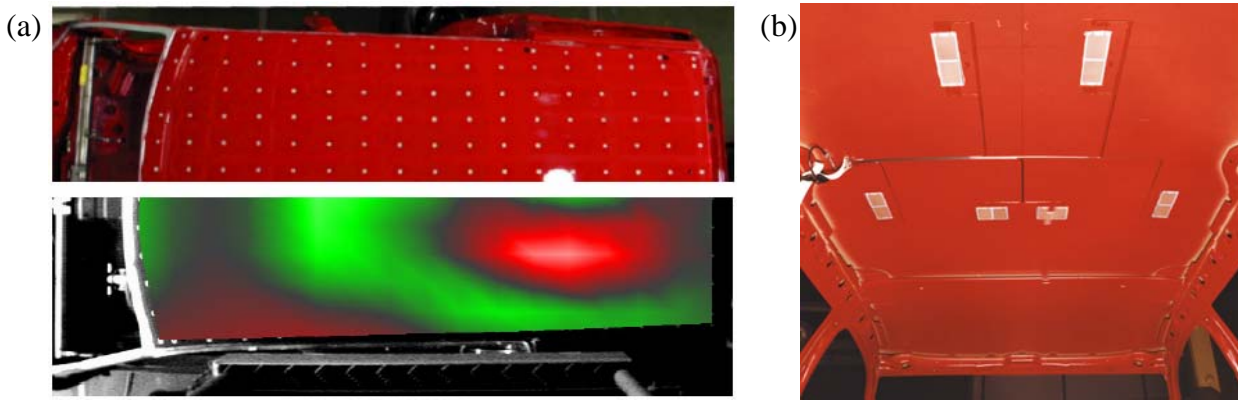

Fig. 5: (a) Experimental modal analysis, (b) Attached piezoceramic patches

In the first step an experimental modal analysis is accomplished to obtain the modal data natural frequency, mode shape and modal damping. The knowledge of these values is of crucial importance for the controller design. First step is the measurement of the operational deflection shapes by means of a laser scanning vibrometer. This data is then processed by a modal analysis software. After determination of the optimal actuator and sensor positions and appropriate application of the piezoelectric patches, the passenger interior noise can be reduced with a suitable controller concept. Thus, the passenger comfort can be increased also in the low frequency band. Additionally, the active noise reduction system can adapt to varying environmental conditions like temperature changes. This means a great improvement in comparison to passive noise reduction measures [7,8]. This project represents a continuation of the work started in the German ‘Leitprojekt Adaptronik’ together with Volkswagen. The high interest of industry in the active control of panel vibrations shows the European Integrated Project “Intelligent Materials for Active Noise Reduction” (INMAR) started in 2004, where the windshield of Golf Mark 5 is investigated to apply the same principle.

2.5 Adaptive convertible

The missing roof structure of convertibles lead to a lower torsional stiffness of their body compared to the body of a saloon car. The lower stiffness results in the body being more susceptible to vibrations of the rear-view mirror, the frame of the windshield and the steering-wheel, due to a lower first eigenfrequency of the body. While these vibrations pose no security or strength durability problem they affect comfort of the passengers, which is considered more and more relevant for acceptance in automotive market.

Conventional methods for increasing the stiffness of the body increase the weight at the same time, effectively keeping the first eigenfrequency unchanged. Other means of vibration reduction like tuned mass dampers suffer from their inability to adapt to changing conditions like closing the roof and changing numbers of passengers.

Together with the industrial partner Karmann which is a leading company in design and construction for automotive industry a feasibility study using smart technologies was conducted.

Using embedded actuators based on piezoceramics as shown in Fig. 6, a reduction of vibration of the windshield of more than 90 % could be achieved on a test stand and a reduction of more than 30% on the road. This reduction was not dependent on changing conditions [9,10].

In the moment Karmann and a spin-off company of DLR are working on bringing this system to the market.

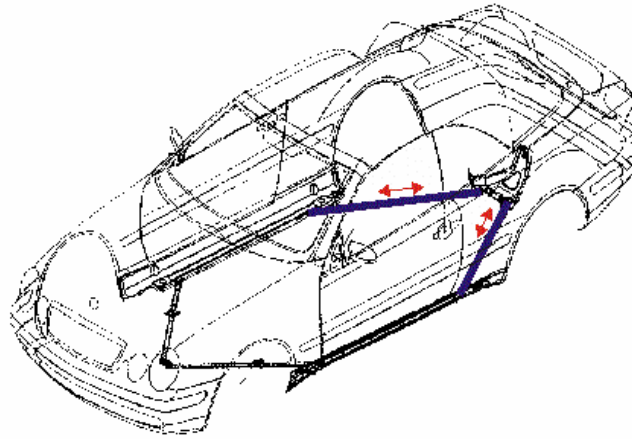

Fig. 6: Active Rods embedded in the frame of the body

2.6 Active rotor blade control

The improvement of air traffic around European airports and the circulation of passengers, who reach and leave airports, is a very well known societal need. Helicopters are able to give a positive answer to this need by quickly flying passengers to/from the airport from/to their departure location/final destination in the vicinity of the airport. This requires a new organization of air traffic around airports, minimising interference with large fixed wing aircraft. To maximize airport traffic, the helicopter will require an independent different flight path to the approach and take off of fixed wing flights. At the other end of the helicopter flights are the heliports and vertiports, which are very close to urban areas, where inhabitants require minimum noise. In addition, the helicopter passenger will expect that the comfort level is comparable to that of aeroplanes, which means decrease in helicopter vibrations. Another use of helicopters is Emergency Medical Service. They require both comfort for passengers and low noise level to be accepted on a long term basis by people living close to hospitals.

The intensive theoretical and experimental work performed both in Europe and the USA shows that BVI (Blade Vortex Interaction), see Fig. 7, is the most intense noise source and can be dramatically reduced (8 to 10dB) by an appropriate control of the blades at frequencies up to 50Hz (compared to the rotor rotation rate of 4 to 6Hz). The BVI appears during some specific flight phases and especially during approach when the helicopter is close to urban areas.

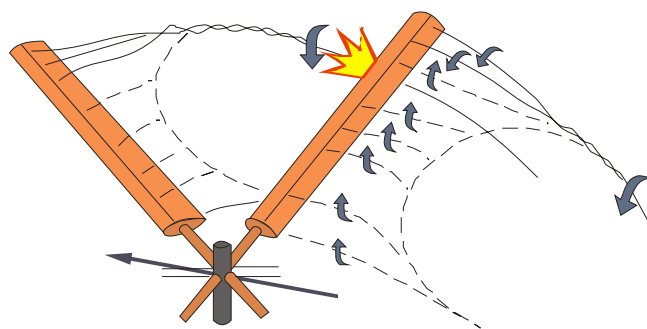

Fig. 7: Blade Vortex Interaction (BVI)

The benefits of Higher Harmonic Control (HHC) and Individual Harmonic Control (IBC) have been demonstrated both theoretically and practically during flight test. The goal of the presented work is the development of an active twist actuation concept. In comparison to other concepts for IBC and HHC active twist concepts offer a variety of advantages:

- High aerodynamic sensitivity
- Very good structural and dynamic compatibility with existing blade designs
- No discrete edges

- Minor influence of actuation forces on blade strength
- Variable distribution of piezo-electric material
- Manufacturing process entirely based on established techniques.
- No moving components involved.

This topic is presently being investigated within the European Integrated Project “Integration of Technologies in Support of a Passenger and Environmentally Friendly Helicopter” (FRIENDCOPTER) and the DLR-ONERA cooperation “Active Twist Blade” (ATB).

In a first step this technology will be demonstrated on a model rotor blade level. The results will be assessed by means of laboratory results, noise and vibration simulations. The goal of this assessment is to evaluate the performance of the active twist concepts with respect to rotor dynamics, stability, aerodynamics, acoustics and piloting. If the concept came up to be feasible it is planned to conduct wind tunnel test to prove the performance of an active twist blade with respect to noise, vibration and performance improvement

The proposed concept comprises the implementation low profile piezoceramic actuators in the blade skin. Concepts like these have been intensively investigated in the US [14,15,16,17] (see Fig. 8).



Fig. 8: Principle of integrated low profile piezoceramic actuators

As low profile actuators so called Macro Fiber Composite (MFC) will be used. These actuators consist of polyimide films with IDE-electrodes that are glued on the top and the bottom of piezoceramic ribbons. This design has been developed by NASA [18] and is now commercially available from Smart Materials Cooperation [19]. Since this technology represents the state of the art in in-plane piezo actuation it has been chosen for the development of the active twist blade demonstrator.

In order to maximize the resulting twist within given constraints such as torsional rigidity and given actuator design, this concept takes advantage of non-isotropy within the rotor blade skin material. That way, a combination of pure shear induction and tension-torsion coupling produces more twist than each one of these effects alone [20,21]. Previous approaches with distributed actuation only used actuators operating in $\pm 45^\circ$ direction with quasi-isotropic composites.

Up to now a detailed FE-Model of the blade has been developed and validated using a test structure with simplified geometry. The design of the final demonstrator is completed and the manufacturing of the model blade is in progress. As a baseline for the design a BO105 model rotor blade was chosen. This is a comparably old design, but the data base for this rotor blade is very large and available. Rotor dynamic simulations provided an initial overview of the active twist rotor performance. In comparison to the BO105 baseline rotor a noise reduction of 3 dB was predicted for an active twist of 0.8° at the blade tip. Additionally, a power reduction of 2.3% at 87m/s based on a 2.5to BO105 was computed.

2.7 Smart wing

Since the first manned flights more than a century ago aviation grew from the days of pioneering to an inherent part of today's traffic system and an important factor for economy. During all time this branch has been characterised by technical enhancement; first to achieve the physical capability vanquishing gravity and later aiming at the improvement of economy related performance and environmental compatibility. A major problem in aircraft design arises from variable optimisation targets resulting from different missions with diverse requirements and distinct flight phases. Conventional structures can only be optimised for one particular design point which usually is chosen in the middle of the flight envelope. Thus, most of the time today's aircrafts are operated in off design conditions with reduced efficiency.

Smart Structures featuring active shape control offer the potential to extend the design point to a design area and increase efficiency significantly. The challenge in this application of smart-structures technology is coping adverse requirements in structural design. The fundamental structural task of a wing is transferring the loads between aerodynamic pressure and inertial forces. Light weight design demands a high strength-to-weight ratio what can only be obtained by exploitation of moments of inertia. Acting on this maxim as well as flutter safe design lead to very stiff structures. The authority of actuators over the passive structure is given by the ratio of stiffness between active and passive components. Hence aircraft wings can benefit a lot from smart structures but are very demanding applications.

Present aircraft wings show a separation of functionality. In chord direction the centre part is a shell based cantilever, called wing box. The leading and trailing sections are bodies which can be moved by conventional mechanic bearings. This solution allows the mandatory adaptation of wing shape to high lift flight conditions but is not appropriate for enhancement of cruise flight performance and additionally infringes on the principle of shell based light weight design. Since these high lift devices do not contribute to over all wing strength their modification to versatile usable smart structures can be realised without penalties, neither in structural mass nor in system complexity nor power consumption.

Especially the trailing edge can influence aerodynamic pressure distribution effectively by smooth structural deflections and has been object of smart structures studies such as the project ADIF (Adaptive Wing). One of the concepts developed by the department of Adaptronics team in the ADIF framework is the so-called *finger* concept, which includes a segmented deformable rib and an open flexible skin [22].

Another promising application is a smart winglet since it is not loaded heavily and has a great influence on aerodynamics. By active twist or camber the outboard lift distribution can be affected and reduction of induced drag is possible. Very large deflections increase drag without loss of lift, what is an important feature for low noise approach and landing. An oscillating activation of the winglet excites tip vortexes, which can disequilibrate natural tip vortexes and cause their quicker decay. This effect permits reduction of traffic separation and increase the infrastructure's capacity. Smart winglets are investigated in the German national research project IHK (Innovative High lift Configurations) and in the FP5 project M-DAW in cooperation with Airbus Industries.

In complement adverse functionalities can be integrated in continuous bodies by elaborate structural designs like the *belt rib* concept. Originally developed within the ADIF Project as an adaptive trailing edge concept, the belt rib idea evolved further in later projects, like the DLR project ADVANCED AIRCRAFT STRUCTURES. It implements the idea of compliant structural systems, which achieve the required degree of deformability by exploiting structural flexibility instead of mutual motion of rigid parts. Belt-rib structures are designed to optimally combine smooth deformability, loadability and light weight [23,24].

Beside structural layout optimisation the design of materials offers a great potential for smart structures. Modern composites can be tailored to resist operational loads and in the same time provide highly elastic regions and orientation for effective activation. This can be realised by anisotropic fibre placement and elaborated actor integration, where the spectrum of possible actors ranges from smartly integrated conventional drives like hydraulic cylinders up to avant-garde multifunctional materials like shape memory polymers. The tailoring implies passive structural coupling effects, which can be utilised additionally to transform natural in flight wing bending energy to desired deflections. This approach is known as aeroelastic tailoring and can be combined with state-of-the-art smart structures concepts in a synergetic manner. This topic was tackled by the DLR project AWiTech (Adaptive Wing Technologies) [25].

The decomposition of structural properties in load bearing, coupling and active orientations requires perfect understanding of the structure and the loads. Unfortunately aerodynamic pressure distribution is coupled with the wing's flight shape and subsequently with its stiffness distribution. This makes an interdisciplinary approach mandatory which considers at least static aeroelasticity; but only multidisciplinary optimisation including all dominant disciplines e.g. dynamic aeroelasticity and systems can exploit the concept's whole potential. An extensive model of the complex wing must be the basis especially when high sophisticated and unconventional structures are investigated for excessive structural adaption. A popular dedicated keyword is morphing which represents techniques exceeding pure enhancement of performance like replacement of conventional control surfaces by active structures ranging up to completely transformable flight characteristics. The concentration of interdisciplinary competence including aircraft manufacturers for enhancing the holistic approach is characteristic for present smart structures projects in the DLR.

2.8 Cabin noise

This projects goal is to increase the noise comfort in aircraft cabins and, thus, improve the passenger's well-being. Although existing passive noise damping measures are well-suited to suppress high frequency noise, they are less efficient with typical low frequent tonal engine noise that is usually transmitted through the fuselage and contributes significantly to the cabin interior noise level. Typically, such noise is of low frequent nature and can be effectively suppressed by active structural damping measures. To address this problem, it is crucial to identify such suitable measures to actively decrease structural born noise in the fuselage and to set up an active structural acoustic control (ASAC) system that controls the relevant noise emitting structural vibrations. Such an active system, which for example uses piezoceramic patch actuators or adaptive absorbers, is complementary to passive insulations, and the combination of the two will extend existing capabilities.

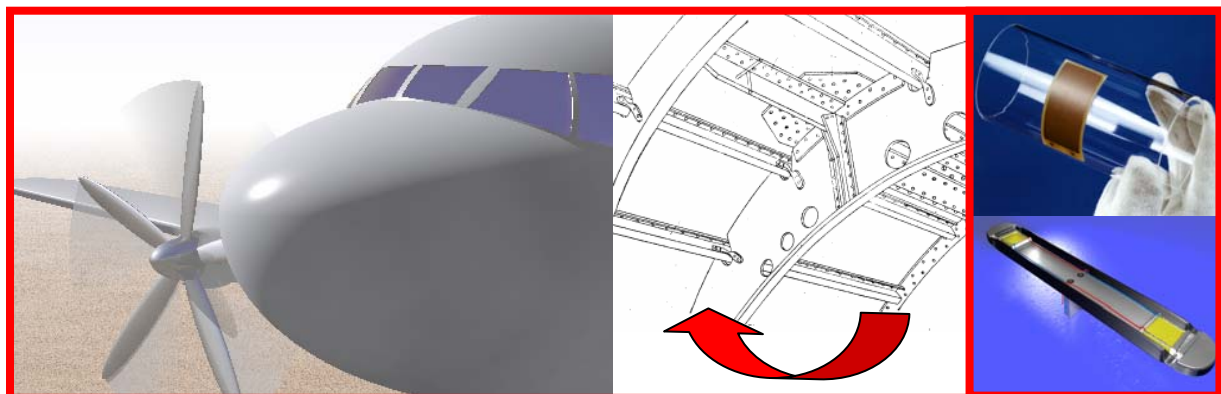

Fig. 9: Schematic ASAC system:
Integration of actuators in aircraft fuselage to suppress structural born noise.

The design, realization and testing of such an ASAC system (see Fig. 9) consists of the two main components modelling/simulation and realization that are interactively linked.

The modelling and simulation spans from structural and acoustic analysis to actuator placement and control design in an iterative loop. As a first step the CAD data of the fuselage is imported into a finite element (FE) software and several structural analyses are run. The results of this computation are used as the loading input for an additional acoustic model to compute the acoustic sound field in the cabins interior. This allows for the identification of relevant noise emitting structural deformations and, thus, for an efficient placement of the active measures mentioned above. Subsequently, the actuators control is designed based on the results from previous analysis and later on implemented into the finite element code as well as the actuators to compute their effect on the structural damping. A succeeding acoustic analysis of the controlled structure reveals the altered sound field and can be judged based on a noise criterion. This is an iterative optimization process chain for the complete system including optimization of actuator shape and layout and control design.

The integrated computer based design process mentioned above only performs structure and acoustic analysis in conjunction with control design. By means of an available hardware fuselage of the regional jet Fairchild-Dornier Do728, this process can be significantly improved through the integration of system identification, since the modelling can be validated by experimental data. Once the ASAC system layout is finished, it is realized and its performance tested in the Do728 fuselage.

2.9 Adaptive lightweight satellite mirror

Orbital structures are, for instance, subjected to temperature cycles from $-150\text{ }^{\circ}\text{C}$ to $+150\text{ }^{\circ}\text{C}$. Such temperatures as well as other harsh environmental conditions are not allowed to influence the performance. For lightweight reflectors this means that the contour always has to be of constant geometry, independent of the environmental conditions. Today this achieved by employing structures of very high stiffness, which is disadvantageous in terms of lightweight construction. In order to overcome this obstacle the following scientific and technological objectives [26] were defined:

- Investigation of the international state of the art concerning active satellite structures with piezoceramic sensors and actuators.
- Design of a prototype component representative for active shape control of satellite reflectors in order to test adaptive technologies on the basis of piezoceramic elements. Emphasize will be put on the adaptive shape control, whereas active vibration attenuation and damage detection will be investigated accompanying.
- Design of a suitable component for active shape control of satellite reflectors to improve the contour accuracy.
- Implementation of the developed piezoceramic fiber and patch technology in the prototype component.
- Demonstration of the functionality comparison with analytical predictions.
- Development of operational and cost-effective constructions for implementing the developed technologies in future satellite structures.

Within the German ‘Leitprojekt Adaptronik’ EADS Dornier was responsible for the development of the adaptive satellite mirror. Based on extensive and detailed numerical investigations a concept for an adaptive lightweight reflector made, out of CFRP was developed. Now the focus is put on the realization of this concept in form of a prototype component. Important questions concerning the construction and handling were answered positively.

Special requirements, like thermal stability and a desired high coverage with active material lead to the development of special encapsulated piezoceramic patches (see Fig. 2(b), section 2.2). The geometric design of the patches is limited by the maximum size of the available piezoceramic wafers

being 50x50mm². Though the surface of the mirror has a slight spatial curvature flat piezoceramic wafers came out to be suitable for this application. The wafers were cut to size to fit the reflector shape. The reflector is divided into segments of 60°. Every segment is again divided in six concentric ring segments. Each of these ring segments represents an encapsulated patch respectively and is made of a different number of piezoceramic wafers with a common electric connection (Fig. 10). These were first integrated into a test segment of a reflector.

The results of the experimental investigation of this test segment were used to update the finite element model of the adaptive reflector. In the mean time the manufacturing of the prototype component has been completed. A new concept for CFRP honeycomb could successfully be established. Two active layers with altogether 72 separate actuators have been manufactured and are being integrated in the prototype component (see Fig. 10). After completing this work the control strategy has to be verified and a qualitative and quantitative evaluation with regard to the feasibility of the complete adaptive system has to be carried out [27].



Fig. 10: Integration of encapsulated patches

2.10 Parallel robotics

Robots based on closed kinematic chains – so called parallel robots – constitute a promising alternative to conventional serial robot structures as they meet the increasing demands with respect to dynamics and accuracy in production technology.

Smart structures technologies are used to further enhance such robotic systems. The objective for using adaptive systems is to either decrease cycle-times or increase precision.

A crucial requirement in order to reach short cycle-times and high precision is minimizing the vibration of the structure in the process of handling or assembly. The means for meeting this requirement is using adaptive systems for active vibration suppression.

The Collaborative Research Center SFB 562, an interdisciplinary research group, consisting of eight institutes of the Technical University of Braunschweig and of the German Aerospace Center, has been established by the German Research Foundation (DFG) in order to develop fundamental concepts and solutions in the field of adaptive parallel robotics. Structural design topics as well as the development of new control schemes and of machine components, particularly designed for parallel robots are covered by the work of SFB 562 [28].

The topics covered by DLR are:

- Modelling and simulation of parallel robots with smart components
- Design and development of smart components, e.g. active rods based on piezo-actuators
- Concepts for robust control of vibrations

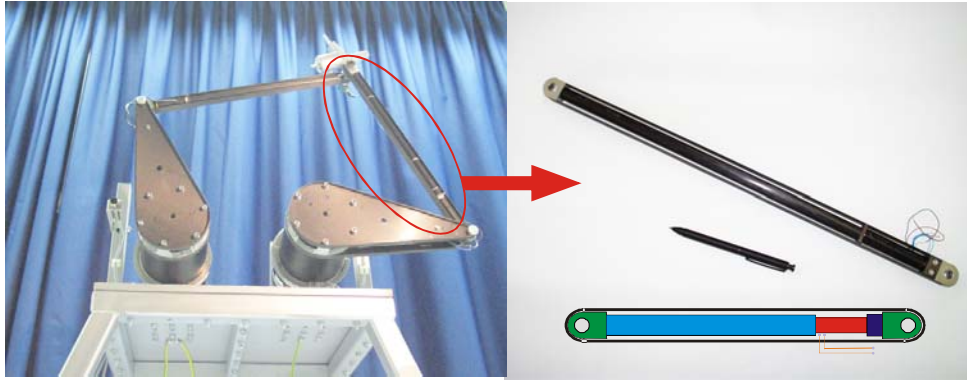

Fig. 11: The Five-Bar parallel robot (left), active rod (right)

Fig. 11 shows the Five-Bar parallel test structure, which was simulated, designed and realized. The active rod, shown on the right, is used in combination with a robust controller to reduce the vibrations of the effector. A maximal disturbance reduction of 18 dB has been achieved robust to mass changes of the structure as shown in Fig. 12. In the time domain this directly corresponds to a shorter decaying time of the effector vibrations resulting in shorter cycle times for handling and assembly [29].

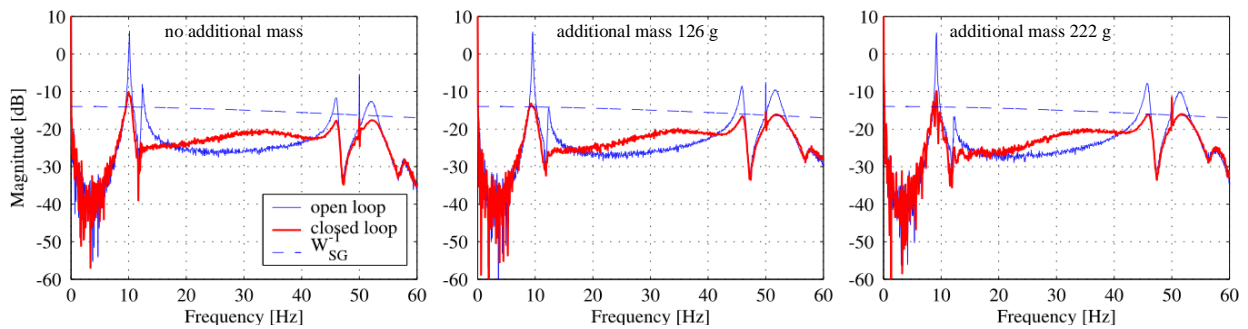

Fig. 12: Open- and closed-loop FRF

In the near future these smart technologies will be implemented on a four DOF Triglode parallel structure, which can be used in real industrial handling and assembling tasks (see Fig. 13).

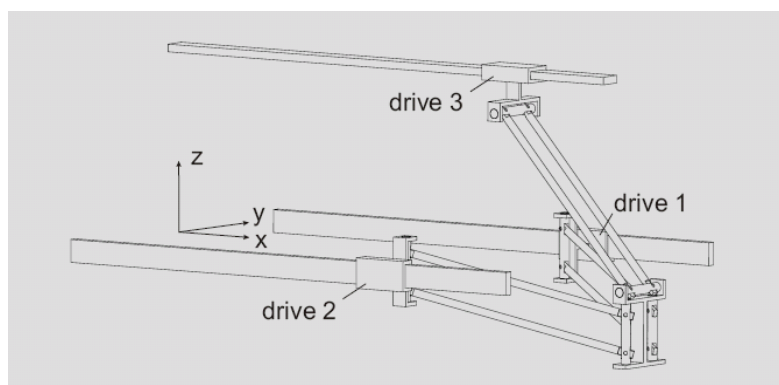

Fig. 13: Triglode parallel robot

2.11 Shunted systems

In 2003 the DFG-Research programme „Adaptronics in Machine Tools” to reduce the vibration on high speed cutting tools was initiated by the Technical University of Braunschweig and the DLR. The vibration of the cutting tool is the source for noise, vibration of the machine and poor quality of the goods. 14 research groups from different universities and research institutes are working

independently on various machine tools tasks. DLR is focussing on so-called shunted systems for rotating systems [30].

Active control of structures is an approved method to reduce the vibrations of a mechanical system. For this goal an actuator with an external power supply is necessary. In many applications it is difficult to feed the external energy in the system to drive the actuator for example in rotating structures like rotor-blades in helicopters or cutting machine tools. A way to handle this problem is to design shunted systems which need no or only very little external energy. If piezoceramic actuators are used the electrodes are connected with an electric circuit. If this circuit can oscillate (therefore an inductivity and a capacity is necessary) it can be tuned to behave like a vibration absorber. Then the mechanical energy from the structure can be transformed to electrical energy via the piezoceramic transducer and dissipated in a resistance. As a result the mechanical vibrations are reduced and no external energy is needed [31].

This method can also be used for multimodal applications but the number of parameters for the electrical circuit increase highly proportional and the performance of the vibration reduction is very sensitivity due to parameter fluctuation from temperature changes or production dispersion. Another problem is the high inductivity needed to match low frequencies of the mechanical structure. So the application of a physical inductivity is not feasible because it is too large and heavy. It is more convenient to build up the electrical network digital to run on a dsp-board. The next step is the implementation of a controller to change the parameters of the network. If the behaviour of the structure changes the parameters of the network can be tuned to match a goal frequency in the best way. For the validation of the theoretical work a test-set-up was build. This consists of a cutting saw with variable speed to run in different rotating speeds and a shaker to give a disturbance on the saw blade. On the saw-blade piezo-patches are bounded with a electrical network. Simulations with such a system show a significant vibration reduction for selected modes (see Fig. 14). These results can also be transferred to other rotating systems.

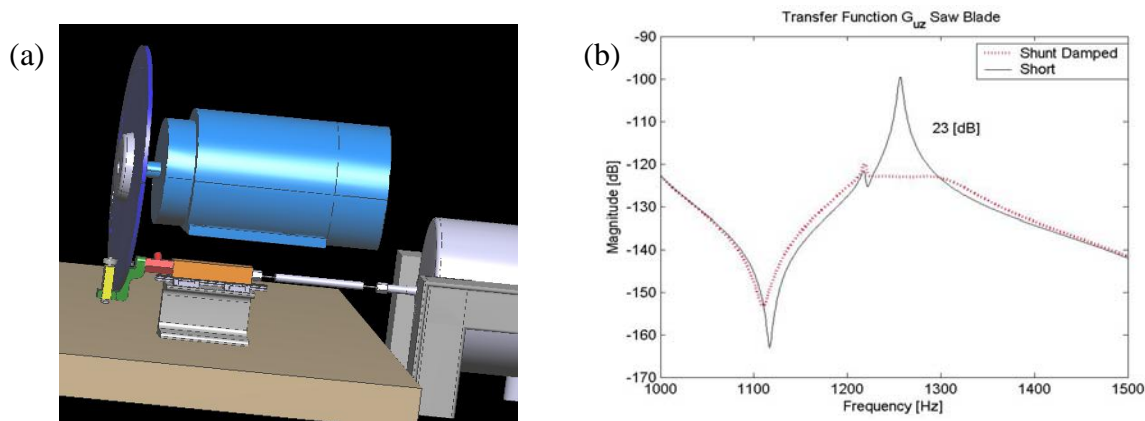

Fig. 14: (a) Test set-up of cutting saw, (b) Simulated vibration reduction

2.12 European Center for Adaptive Systems (ECAS)

The wide-spread application of innovative system solutions like smart-structures technology, however, is not possible without targeted knowledge and technology transfer. Insights from research and development must be implemented faster into marketable products. Practical implementation requires the cooperation of business and science via networks or cooperations. Strategic development, production or marketing alliances provide exceptional opportunities to do so.

As a result, the German Aerospace Center, in collaboration with the government of Lower Saxony, decided to create a European Center of Adaptive Systems – ECAS.

The goal is the development of a service and vocational education / training center as a central point of contact that will provide the market with a comprehensive service offer

- as a source of information and orientation
- as a technology broker and manager
- as well as an advanced training and specialization partner.

The performance profile concentrates on the following four competency modules:

- research and teaching (basic principals and application, public) → technology leadership
- vocational and advanced training (privat sector) → improvement of employment opportunities
- as well as realization → integration of the industry
- and marketing → penetration of the market

The ECAS performance profile is based on the following Module (see Fig. 15):

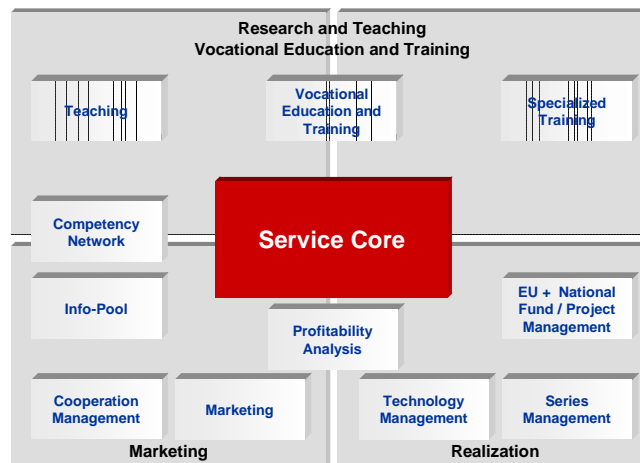

Fig. 15: Detailed performances profile

On May 31st 2005 all founder members (DLR, VW AG, EADS-CRC, OHB-System AG, Kayser-Threde GmbH, Otto Bock Group, ERAS GmbH) signed a contract in collaboration with the government of Lower Saxony to build up ECAS.

3. FINAL REMARKS

When implementing smart-structures technology into industrial applications and products typical challenges include low actuator stroke, expensive/heavy electronics, lack of system reliability information, manufacturability, reparability, recycling, implementation of robust distributed adaptive control strategies, and unavailability of reliable smart systems mathematical modelling and analysis. Depending on the system requirements the one or the other challenge is more dominant. However, tremendous progress has been made in all of these different tasks during the past decade allowing smart-structures technology to emerge into all kinds of industrial products. Following some details to these challenges are discussed:

Low actuator stroke: In smart-structures technology piezoelectric ceramics are first choice. They generate large forces, have fast response times, are commercially available as fibres, patches and

stacks and allow integration into structural components. Other commercialized smart materials are magnetostrictives and electrostrictives which have by far not reached the popularity of piezoelectric ceramics. However, the major limitation of these materials is their low actuator stroke. Another commercially available smart material, the shape memory alloy, is capable of generating large strokes and forces, but they have a very low bandwidth and require continuous heating for actuation. Therefore, in the past decade much effort has been made to generate new materials with larger strain rates. Especially the field of electroactive polymers has led to the development of a considerable amount of promising materials which are able to perform very large active strains. Also the ferromagnetic shape memory alloys recently discovered are capable of generating large actuator strokes. However, also these new materials have their limitations. Especially their low mechanical stiffness presently only allows to produce comparably low forces. Though these new smart materials are partially far from being mature they show great potential to open up many new frontiers of application. Research in the field is proceeding with an enormous dynamics meaning that new or improved smart materials can be expected for the future. A detailed overview of smart materials can be found in [32].

Expensive/heavy electronics: Hardware for controllers and signal processing have significantly improved both concerning cost and weight due to the increasing demand in large volume branches like automobile industry over the past years. Bottleneck is often the power electronics. Small power electronics that operates at voltages of many hundred up to several thousand volts, such as transistors and integrated circuits, are rarely available from the shelf. However, there are no fundamental obstacles to the further development of such devices. The currently available selection reflects the existing market demand rather than technology limitations.

Lack of system reliability information: The reliability prediction for the complete smart system involving structural material, distributed actuators and sensors, control strategies, and power conditioning electronics can be very difficult, especially when the smart system and the environmental conditions are very complex. For the commercialised smart materials the manufacturer often has data available for various load cases which often allows good prediction for the material itself. Due to competitive reasons this data is almost always unpublished and only made available to potential customers. When these materials are integrated, e.g. piezoceramic patches into CFRP, only very fractional data is available and distributed over many publications and far from being complete. Presently, apart from simple mono- or bimorphs, reliability predictions for more complex structures which are elasto-mechanically influenced by smart materials are not possible and require specific extensive reliability tests. In future a suitable reliability database for different combinations of smart materials, structural materials and load cases is required in order to accelerate the design phase for smart systems. Concerning the electronics vast experience is available for the reliability of controller hardware, signal processing and power electronics within the electronics departments of various firms.

Manufacturability: Dependant on the volumes required a high degree of automation is possible for smart systems. There are various types of large volume manufacturing technologies in different branches available which can be adapted to smart systems mass production. However, due to mainly small volumes being required smart systems presently involve a significant amount of manual work. Since the demand is increasing, e.g. in the European integrated project INMAR – “Intelligent Materials for Active Noise Reduction” large volume concepts for piezoceramic patch actuators and their integration/attachment are being developed.

Repairability: For smart structures with integrated actuators and sensors this is a serious issue and not solved up to date. The trend is to develop damage tolerant sensors and actuators which provide sufficient performance also when broken without being critical for the structural performance. Actuators and sensors externally bonded to a structure can be removed when appropriate adhesives, e.g. thermoplastic resins, are used. However, depending on the requirements of the application new concepts have to be developed in the future.

Recycling: A topic very rarely investigated in the past, simply because large volume applications with the need of recyclable systems have not emerged, yet. With the automobile industry and many others seriously considering smart systems for future large volume applications this question is of fundamental importance. E.g., the automobile manufacturers in Germany are bound to take back all cars sold after 1. July 2002 – free of charge. Therefore, research activities in this direction are gaining on momentum. Piezoceramics without lead, detachment technologies for piezoceramic patches, etc. are presently being investigated.

Implementation of robust distributed adaptive control strategies: The theoretical background for adaptive controllers as well as robust controllers like H_∞ and H_2 has been extensively described in literature. However, the implementation of such controllers is often very time consuming because a large amount of parameters has to be adjusted. For the future automated adaptation procedures have to be developed in order to efficiently be able to implement controllers on complex smart structures.

Unavailability of reliable smart systems mathematical modelling and analysis: For the linear behaviour of integrated/attached smart materials analytical formulations have sufficiently been described in many publications for rods, beams, plates, and shells. However, the implementation into commercial programs is only very sparse meaning the modelling of such systems can be very time consuming. In FE programs often the thermal analogon is used where the active strain is introduced by a thermal load in layered elements due to the lack of active plate or shell elements. When the highly non-linear multi-field behaviour of the smart materials, e.g. hysteresis of piezoceramics or complex stress-strain-temperature relationship of SMA, has to be considered reliable material models still are not available, though large progress has been made in the last years as can be found in literature. Commercially no non-linear materials model is available. This can be very problematic since e.g. in active structural acoustic control (ASAC) non-linearity of piezoceramic patches may cause additional noise.

4. LITERATURE

1. E. Breitbach, H. Hanselka: Antrag BMBF-Leitprojekt ADAPTRONIK, Förderkennzeichen 03 N 85161 1, DLR Braunschweig, 1998
2. Monner, H. P.; Hanselka, H.; Breitbach, E. J.: *New Results and Future Plans of the German Major Project ADAPTRONICS*, SPIE's 9th International Symposium on Smart Structures and Materials, 17-21 March, 2002
3. P. Wierach, H. P. Monner, A. Schönecker, J. K. Dürr, "Application Specific Design of Adaptive Structures with Piezoceramic Patch Actuators", SPIE's 9th Annual International Symposium on Smart Structures and Materials, March 2002, San Diego
4. E.F. Crawley, E.H. Anderson, "Detailed Models of Piezoceramic Actuation of Beams", 1989, AIAA Journal
5. H. Hanselka, H.P. Monner, V. Krajenski, *Hochintegrierte Materialsysteme für adaptive Leichtbaustrukturen*, 1996, Adaptronic Congress, Berlin
6. P. Wierach, A. Schönecker, „Bauweisen und Anwendung von Piezokompositen in der Adaptronik“, Adaptronic Congress 2005, 31. May – 1. June 2005, Göttingen, Germany
7. T. Weyer, H. P. Monner, „PKW-Innenlärmreduzierung durch aktive Beruhigung der durch die Mororharmonischen erregten Dachblech-Schwingungen“, *Motor- und Aggregate-Akustik*, Kapitel 18, Expert Verlag, 2003, ISBN 3-8169-2260-0
8. K. Schmidt, V. Thörmann, T. Weyer, D. Mayer, S. Herold, V. Krajenski, "Aktive Schwingungskompensation an einer PKW-Dachstruktur", Adaptronic Congress 2003, 1.-3. April 2003, Wolfsburg, Germany
9. R. Keimer, M. Matthias, J. Melcher, „Machbarkeitsstudie zum aktiven Schwingungsreduktionssystem (ASRS)“, DLR-IB, 131 – 98/28, (1998)
10. P. Kalinke, U. Gnauert, H. Fehren, „Einsatz eines aktiven Schwingungsreduktionssystems zur Verbesserung des Schwingungskomforts bei Cabriolets“, Adaptronic Congress 2001, 4-5 April

2001, Berlin

11. Baughman R.H. et al; Carbon Nanotube Actuators; Science 284, 1340 (1999)
12. Riemenschneider J., Mahrholz T., Mosch J., Monner H. P., Melcher J.; 'Carbon Nanotubes - Smart Material of the Future: Experimental Investigation of the System Response'; II ECCOMAS thematic conference on smart structures and materials, C.A. Mota Soares et al. (Eds.), Lisbon, Portugal, July 18 - 21, 2005
13. Monner H. P., Mühle S., Wierach P., Riemenschneider J.; Carbon Nanotubes - ein multifunktionaler Leichtbauwerkstoff für die Adaptronik; Adaptronik Congress 2003, April 1-3, Wolfsburg, Germany
14. Derham, Hagood; "Rotor Design Using Smart Materials to Actively Twist Blade"; 52nd Annual Forum of the American Helicopter Society 1996
15. Cesnik et al; "Modeling, Design and Testing of the NASA/ARMY/MIT Active Twist Rotor Prototype Blade"; 55th Annual Forum of American Helicopter Society 1999
16. Derham et al; "The Design Evolution of an Active Materials Rotor"; 57th Annual Forum of the American Helicopter Society 2001
17. Wilkie, W., High, J., Mirick, P., Fos, R., Little, B., Bryant, R., Hellbaum, R., Jalink, A., "Low Cost Piezocomposite Actuator for Structural Control Applications, Proceedings SPIE's 7th International Symposium on Structures and Materials, Newport Beach, California, March 5-9, 2000
18. Bent, A. A., Hagood, N.W., and Rodgers, J.P., Anisotropic Actuation with Piezoelectric Fiber Composites", Journal of Intelligent Materials Systems and Structures, Vol. 6, May 1995
19. <http://www.smart-material.com>
20. Andreas Büter, Elmar Breitbach, "Adaptive Blade Twist – calculations and experimental results" Aerosp. Sci. Technol. 4 (2000) 309-319
21. Johannes Riemenschneider, Peter Wierach, Stefan Keye, "Preliminary Study on Structural Properties of Active Twist Blades", 29th European Rotorcraft Forum; Friedrichshafen, Germany; 16.09.2003-18.09.2003
22. Monner, H. P., 2001. "Realization of an optimized wing camber by using formvariable flap structures", Aerospace Science and Technology 5, 445-455.
23. Campanile, L.F. and Sachau, D., 2000. "The belt-rib concept: a structronic approach to variable camber", Journal of Intelligent Material Systems and Structures, 11 (3), pp. 215-224.
24. Campanile, L.F., Rose, M. and Breitbach, 2004. "Synthesis of flexible mechanisms for airfoil shape control: a modal procedure", Proc. of the 15th International Conference on Adaptive Structures and Technologies, Bar Harbour, ME, USA, October 2004.
25. Nagel, B., Monner, H. P., Breitbach, E., 2004, "Aerolastic Tailoring transsonischer Tragflügel auf Basis anisotroper und aktiver Strukturen", Proc. of the German Aerospace Congress, Dresden, Germany, September 2004
26. J.K. Dürr, U. Herold Schmidt, H.W. Zaglauer, D. Scheulen, R. Sippel, "Smart Composites for Adaptive Satellite Mirrors", 2000, Adaptronik Congress, Potsdam
27. J. K. Dürr, R. Honke, M. V. Alberti, R. Sippel: Analysis and Design of an Adaptive Lightweight Satellite Mirror, (to be issued) SPIE's 9th International Symposium on Smart Structures and Materials, 17-21 March, 2002
28. Rose, M.; Keimer, E.; Breitbach, E.J.; Campanile, L.F.: Parallel Robots with Adaptronic Components. In: 13th International Conference on Adaptive Structures and Technologies (ICAST), S. 11, Potsdam, October 2002
29. S. Algermissen, M. Rose, R. Keimer, E. Breitbach, "High-Speed Parallel Robots with Integrated Vibration-Suppression for Handling and Assembly", SPIE - 11th Annual International Symposium on Smart Structures and Materials, San Diego, California, USA, March 2004
30. S. Homann, M. Rose, E. Breitbach, "Hybride elektromechanische Netzwerke mit piezoelektrischen Komponenten", Adaptronik Congress 2005, 31. May - 1. June 2005, Göttingen, Germany
31. N. W. Hagood, A. von Flotow, "Damping of Structural Vibrations with Piezoelectric Materials and Passive Electrical Networks", Journal of Sound and Vibration, Vol. 146 (1991) No. 2 pp. 243-268

32. Monner, H. P.: Smart materials for active noise and vibration reduction, Noise and Vibrations – Emerging Methods (Novem 2005), Saint-Raphaël, France, 18.-21. April 2005