

ISSN 1866-721X

4<sup>th</sup> SmartRaCon Scientific Seminar - Proceedings

DLR-TS 1.39



Deutsches Zentrum  
für Luft- und Raumfahrt

Proceedings

Berichte aus dem DLR-Institut  
für Verkehrssystemtechnik

Band 39

## 4<sup>th</sup> SmartRaCon Scientific Seminar



# Reports of the DLR-Institute of Transportation Systems

## Volume 39

### Proceedings of the 4<sup>th</sup> SmartRaCon Scientific Seminar

October 20. 2022  
Donostia-San Sebastián, Guipúzcoa, Spain

**Publisher:**

Deutsches Zentrum für Luft- und Raumfahrt e.V.  
Institut für Verkehrssystemtechnik  
Lilienthalplatz 7, 38108 Braunschweig

**ISSN 1866-721X**

DLR-TS 1.39

Braunschweig, October 2022

Institute Director:  
Prof. Dr.-Ing. Michael Ortgiese



# Preface

Dear reader,

you are holding the newest volume of the series „Reports of the DLR-Institute of Transportation Systems“ in your hands. In this series we publish fascinating scientific research results from our Institute of Transportation Systems at the German Aerospace Center (Deutsches Zentrum für Luft- und Raumfahrt e.V. - DLR) and its collaborating partners.

With this series we communicate results of our scientific work in the fields of automotive, railway systems and traffic management. We hope to enable a broad access to scientific work and results for the national and international scientific community and practitioners in the field of transportation. Beyond that, researchers in the early phase of their academic career of our staff and external doctoral candidates are offered the opportunity to publish their dissertation. In addition, the publication includes outstanding scientific contributions and project reports as well as proceedings of conferences in our house with different contributors from science, economy and politics.

The current volume contains the proceedings of the fourth SmartRaCon Scientific Seminar, which has been held on October 20st, 2022 hybrid remotely and in presence from San Sebastian, Guipúzcoa, Spain. This SmartRaCon Scientific Seminar aimed to bring together researchers from different railway research areas with focus on traffic management, train integrity, adaptable communications as well as KPI and energy assessment. The seminar was a vivid and fruitful forum for the presentation and discussion of new and on-going research.

We wish you an interesting and inspiring reading!

Prof. Dr.-Ing. Michael Ortgiese

**All contributions have been double refereed as abstract and full paper by the International Scientific Committee**

## **International Scientific Committee**

Dr. Michael Meyer zu Hörste (DLR, Braunschweig, Germany)  
Dr. Iñigo Adin (CEIT, San Sebastian, Spain)  
Dr. Itziar Apezetxea (CEIT, San Sebastian, Spain)  
Dr. Sergio Arana (CEIT, San Sebastian, Spain)  
Prof. Mats Berg (KTH, Stockholm, Sweden)  
Dr. Alfonso Brazalez (CEIT, San Sebastian, Spain)  
Dr. Pablo Ciaurriz (CEIT, San Sebastian, Spain)  
Dr. Nerea Fernandez (CEIT, San Sebastian, Spain)  
Svenja Hainz (DLR, Braunschweig, Germany)  
Michael Hutchinson (GMV NSL, Nottingham, United Kingdom)  
Dr. Miguel Martinez Iturralde (CEIT, San Sebastian, Spain)  
Dr. Emilie Masson (RAILENIUM, Lille, France)  
Dr. Jaizki Mendizabal (CEIT, San Sebastian, Spain)  
Dr. Gorka de Miguel (CEIT, San Sebastian, Spain)  
Dr. Ida Kristofferson (VTI, Stockholm Sweden)  
Dr. Insaf Sassi (RAILENIUM, Lille, France)

## **Host**

The 4<sup>th</sup> SmartRaCon Scientific Seminar was hosted by CEIT, Donostia-San Sebastián, Guipúzcoa, Spain



<http://www.ceit.es/>

## **SmartRaCon Steering Committee**

Dr. Marion Berbineau (COSYS, Université Gustave Eiffel, IFSTTAR, Villeneuve d'Ascq, France)  
Michael Hutchinson (GMV NSL, Nottingham, United Kingdom)  
Dr. Emilie Masson (IRT RAILENIUM, Famars, France)  
Dr. Jaizki Mendizabal (CEIT, San Sebastian, Spain)  
Dr. Michael Meyer zu Hörste (DLR, Braunschweig, Germany)

## **Organising Committee**

Dr. Jaizki Mendizabal (CEIT, San Sebastian, Spain)  
Dr. Sergio Arana (CEIT, San Sebastian, Spain)  
Dr. Jon Grijalbo (CEIT, San Sebastian, Spain)  
Dr. Michael Meyer zu Hörste (DLR, Braunschweig, Germany)

# Table of Contents

<b>Preface</b> .....	<b>iii</b>
<b>1 Introduction by SmartRaCon: The way forward</b> .....	<b>1</b>
<i>Marion Berbineau, Université Gustave Eiffel, Villeneuve d’Ascq, France; Michael Hutchinson, GMV NSL, Nottingham, United Kingdom; Emilie Masson, IRT RAILENIUM, Famars, France; Jaizki Mendizabal, CEIT, San Sebastián, Gipuzkoa, Spain; Michael Meyer zu Hörste, German Aerospace Center (DLR), Braunschweig, Germany</i>	
<b>2 Demonstration of Automation and Efficiency: The X2Rail-4 perspective for CCS-Systems of Future</b> .....	<b>11</b>
<i>Philippe Prieels, Alstom, Charleroi, Belgium; Michael Meyer zu Hörste, German Aerospace Center (DLR), Braunschweig, Germany</i>	
<b>3 Quantitative Safety Requirements of the New Onboard Train Integrity Function</b> .....	<b>19</b>
<i>Insaf Sassi, IRT RAILENIUM, Famars, France; El-Miloudi El-Koursi, Université Gustave Eiffel, Villeneuve d’Ascq, France; Dominique Renaux, Université Polytechnique Hauts-de-France, Valenciennes, France; Joffrey Clarhaut, Université Polytechnique Hauts-de-France, Valenciennes, France; Julie Beugin, Université Gustave Eiffel, Villeneuve d’Ascq, France</i>	
<b>4 Laboratory Simulation for On-Board Train Integrity</b> .....	<b>29</b>
<i>Gorka de Miguel, David Izquierdo, Jon Goya, Jaizki Mendizabal; CEIT, San Sebastián, Gipuzkoa, Spain</i>	
<b>5 Statistical model checking-based performance analysis of the onboard train integrity</b> .....	<b>37</b>
<i>Insaf Sassi, IRT RAILENIUM, Famars, France; Mohammed Ghazel; Université Gustave Eiffel, Villeneuve d’Ascq, France; El-Miloudi El-Koursi, Université Gustave Eiffel, Villeneuve d’Ascq, France</i>	
<b>6 Cost Benefit Analysis for OTI – Methodology and Results</b> .....	<b>47</b>
<i>Alessa Isberner, Benedikt Scheier, Florian Brinkmann, German Aerospace Center (DLR), Institute of Transportation Systems, Braunschweig, Germany</i>	
<b>7 An iterative algorithm for the coordinated train rerouting and rescheduling problem</b> .....	<b>55</b>
<i>Xiajie Yi, IRT Railenium, Famars, France; Grégory Marlière, Université Gustave Eiffel, Villeneuve d’Ascq, France; Paola Pellegrini, Université Gustave Eiffel, Villeneuve d’Ascq, France; Joaquin Rodriguez, Université Gustave Eiffel, Villeneuve d’Ascq, France; Raffaele Pesenti, Università Ca’ Foscari Venezia, Venice, Italy.</i>	

**8 Performance evaluation of data collection and forwarding in NEWNECTAR architecture based on a reconfigurable wireless transceiver..... 63**

*Dereje Mechal Molla, Université Gustave Eiffel, Marne - la- Vallée, France; Ali Sabra, IRT Railenium, Villeneuve d’Ascq, France; Hakim Badis, Université Gustave Eiffel, Marne - la- Vallée, France; Marion Berbineau, Université Gustave Eiffel, Villeneuve d’Ascq, France*

**9 Electromagnetic Energy Harvesting and Wireless Power Transfer Novel Concepts for the Railway Environment..... 73**

*Mohammed Kalaagi, IRT Railenium, Villeneuve d’Ascq, France; Divitha Seetharamdoo, Université Gustave Eiffel, Villeneuve d’Ascq, France*

**10 Ontology-based Conceptual Model Development for the Railway Domain: A Maintenance Case Study ..... 83**

*Christian Rahmig, German Aerospace Center (DLR), Institute of Transportation Systems, Braunschweig, Germany; Sana Debbech, IRT Railenium, Valenciennes, France; Itxaro Errandonea, CEIT, San Sebastián, Gipuzkoa, Spain; Saioa Arrizabalaga, CEIT, San Sebastián, Gipuzkoa, Spain*

**11 The KPI-Model – An integrated KPI assessment methodology to estimate the impact of different innovations in the railway sector..... 97**

*Filiz Kurt, Alessa Isberner, Michael Meyer zu Hörste, German Aerospace Center (DLR), Institute of Transportation Systems, Braunschweig, Germany; Jürgen Ernst, Deutsche Bahn AG, München, Germany; Abderrahman Ait Ali, Swedish National Road and Transport Research Institute (VTI), Stockholm, Sweden*

**12 Gaining accurate input data for a comprehensive assessment of the railway system ..... 109**

*Alessa Isberner, German Aerospace Center (DLR), Institute of Transportation Systems, Braunschweig, Germany; Svenja Hainz, German Aerospace Center (DLR), Brussels, Belgium; Ida Kristoffersson, Swedish National Road and Transport Research Institute (VTI), Stockholm, Sweden; Jürgen Ernst, Deutsche Bahn AG, München, Germany; Chengxi Liu, Swedish National Road and Transport Research Institute (VTI), Stockholm, Sweden*

**13 IMPACT-2 methodology to include customer experience improvements in modal shift estimations ..... 117**

*Ida Kristoffersson, Swedish National Road and Transport Research Institute (VTI), Stockholm, Sweden; Antoine Verrier, SNCF, Saint-Denis, France; Chengxi Liu, Swedish National Road and Transport Research Institute (VTI), Stockholm, Sweden; Filiz Kurt, German Aerospace Center (DLR), Institute of Transportation Systems, Braunschweig, Germany; Frédérick Getton, Elodie Vannier, SNCF Réseau, Saint-Denis, France*

**14 Development of energy assessment methodology and simulation tool in Shift2Rail projects FINE1 and OPEUS..... 131**

*Holger Dittus, German Aerospace Center (DLR), Institute of Vehicle Concepts, Stuttgart; Lukas Proehl, University of Rostock, Rostock, Germany*

**15 Authors Index ..... 139**







# 1 Introduction by SmartRaCon: The way forward

*Marion Berbineau; COSYS, Université Gustave Eiffel, IFSTTAR, Villeneuve d'Ascq, France*

*Michael Hutchinson; GMV NSL, Nottingham, United Kingdom*

*Emilie Masson; IRT RAILENIUM, Famars, France*

*Jaizki Mendizabal; CEIT, San Sebastián, Guipúzcoa, Spain*

*Michael Meyer zu Hörste; DLR, Braunschweig, Germany*

## 1.1 Smart Rail Control Systems - SmartRaCon

Innovative technologies enable new approaches for train control, command and signaling systems. E.g. digitalization and automation lead to completely new concepts. The partners RAILENIUM, GMV NSL, CEIT and DLR founded the consortium Smart Rail Control (SmartRaCon) to develop new concepts, approaches and technologies for the train control, command and signaling systems of the future in the frame of Shift2Rail IP2. In this contribution, the developments in the areas of Train Integrity, Traffic Management System and Smart Wayside Object Controller will be discussed.



Figure 1-1: SmartRaCon Logo

Digitalization and Automation will prepare the ground for a completely new generation of train control and railway management systems. In the frame of X2Rail-4 [3], SmartRaCon aimed to work on design and development of technology for on board train integrity system, Traffic Management System and Smart Wayside Object Controller.

Some of the concepts to be explored are:

- On board train integrity
  - Safety requirements
  - Laboratory simulations
  - Statistical model checking based performance analysis

- Cost Benefit Analysis
- Traffic Management System
  - Iterative algorithm for a coordinated train rerouting and rescheduling
- Smart Wayside Object Controller
  - Performance evaluation of data collection and forwarding in NEWNECTAR architecture based on a reconfigurable wireless transceiver
  - Electromagnetic Energy Harvesting and Wireless Power Transfer Novel Concepts for the Railway Environment

The overall concept is based on developing novel analyses and tools required for the development, validation and certification, with the idea to reuse COTS and integrating them into a railway network in a modular way. This allows on the one hand a flexible scaling of the rail control system in a cost-efficient way and on the other hand a building block approach for certification and modulewise change of technology.

## 1.2 The methodology

Smart Railway Control (SmartRaCon) will be the core to enable high capacity and cost-efficient rail systems for the next century. The proposed approach of SmartRaCon is to control smartly intelligent, autonomous trains on a scalable and more flexible infrastructure. Main challenges for the rail system are the enhancement of capacity, the reduction of investment and operations cost. The reductions of energy consumption as well as the reduction of cost for test and certification are two aspects for the cost reduction. These are the conceptual objectives of SmartRaCon [1] and are coherent with the Master Plan topics of Shift2Rail [2]. The SmartRaCon idea for a credible, coherent and long-term approach to achieve the Master Plan Objectives is to meet those challenges by:

- intelligent trains, which communicate safely & securely, localize & supervise integrity autonomously and operate as virtual coupled train-sets;
- infrastructure which is flexible, easy & fast to configure, less fixed (e.g. wired) & scalable, communicating safely & securely with trains and operating them in moving block;
- traffic management system operating both with optimization algorithms;
- supported by cost-efficient process for design, test and certification which uses highly automated test labs to avoid on-site tests based on formal test specifications.

For the capacity increase, an integrated moving block (MB) system has to be implemented. Hence technologies work together: train positions need to be reported safely & securely in real-time to the trackside train control and traffic management system (TMS). Positioning and communication are ensured by combining different technologies. To implement the MB logic

on-board train integrity (TI) supervision is required, applying similar technologies. An evolution of the TMS is needed to adopt the MB logic besides increasing the efficiency of dispatching. Virtual coupled train-sets can help to improve capacity by reducing the number of train routes required. The approach is fully in line with the standardized European Rail Traffic Management System (ERTMS) and the European Train Control System (ETCS) and enhances interoperability. New functionalities & technological solutions require being formally specified and tested. Hence testing needs to be automated & moved from on-site to lab. This achieves the objectives of reliability, improved standardization, lower costs & simplified processes. This prioritization is justified since traffic management, positioning and communication are enabling technologies that need to be tested and certified. The complementary work in areas as e.g. moving block and decentralized interlocking technologies extends the concept to reach a significant and sustainable effect on capacity & cost.

### 1.3 Technological research areas

The overall SmartRaCon concept is based on technology-independent adaptable train-to-ground communications resilient to radio technology evolution, ensuring safety levels of GNSS based on-board positioning and train integrity supervision. Some of the most relevant areas of SmartRaCon technological research are shown in Fig. 1-2 and the conceptual groups part of the 4th SmartRaCon Scientific Seminar (SRC4SS) "On-Board Train Integrity", "Optimized Traffic Management" and "Smart radio connected wayside Elements" as well as Conceptual Data Model, KPI Model, Combined Customer Experience Model & Modal Shift Model, Data and System Platform Demonstrator definition, Energy Simulation related to X2Rail-4 [3], IMPACT-2 [4], FINE2 [5], Linx4Rail [6] and Linx4Rail-2 [7] projects are discussed below.

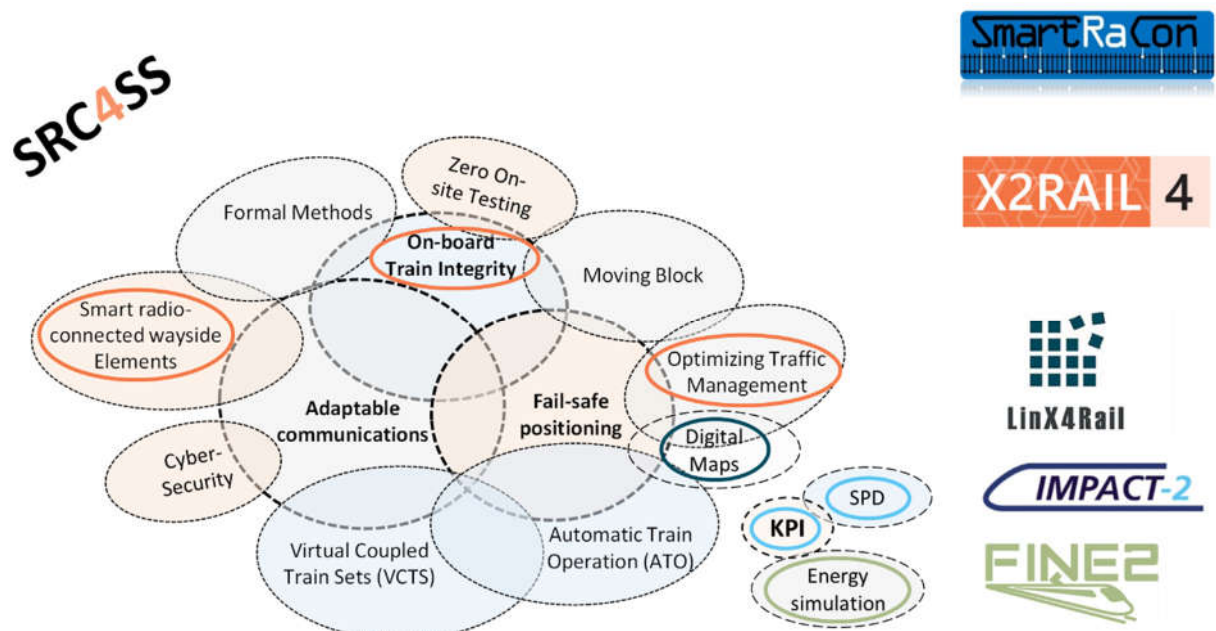

Figure 1-2: Core Areas of Research in SmartRaCon and related projects for the SRC4SS

#### 1.3.1 Conceptual group "On board train integrity"

On-board train integrity determination for the implementation of more efficient signalling systems based on concepts like moving block. The key issue for the overall concept of on-board train integrity determination is that this function becomes mandatory for the implementation

of more efficient signalling systems based on concepts like moving block. Systems based on these concepts will deliver very significant advantages in terms of capacity (shorter headways will be allowed), capital and maintenance cost (expensive track infrastructure for block detection will be obsolete), resiliency, and others such as compatibility among lines, etc.

### **1.3.2 Conceptual Group “Optimized Traffic Management”**

Future traffic management systems, which can optimize capacity, punctuality or energy-consumption require among others real-time precise localization and automated processes for data integration and exchange with other rail business services. The new architecture will allow predictive and dynamic traffic management in both regular and degraded situations for what new algorithms are required. It will use and integrate real-time status and performance data from the network and from the train, using on-board train integrity solutions and network object control functions, supported by wireless network communication.

### **1.3.3 Conceptual Group “Smart Wayside Object Controllers”**

Smart radio-connected wayside elements require a highly safe and secure communication that will enable autonomous, complete, intelligent, self-sufficient smart equipment (‘boxes’) able to connect control centres (e.g. interlocking) and other wayside objects and communicating devices in the area (by radio or satellite), as well as on-board units. Data transferring performance as well as power supply management are key aspects considered.

### **1.3.4 Further conceptual Groups**

The three above mentioned conceptual groups are related to many others in the context of future systems. Some examples are given below and visualization is given in Fig. 1-2.

- Automatic train operation requires a high performance adaptable communication as well as safe and precise localization.
- Virtual coupled train sets allow operating trains much closer to one another and dynamically modifying their own composition on the move, and requires very precise and highly safe absolute and relative localization as well as adaptable train-to-train and train-to-trackside communications.
- Adaptable train-to-ground communications system resilient to radio technology evolution considering threats such as interferences or cyber-attacks.
- Localization is based on the need to ensure that the safety levels provided by existing signaling systems are not compromised when a train-borne positioning system is employed. SmartRaCon covers activities and concepts related to test campaigns, improve specifications, safety case, simulation based KPI evaluation, multi-constellation, sensor integration, developing and certifying dedicated hardware, algorithms.
- Freight telematics needs an adaptable communication and localization.

- Moving block operation requires safe localization and train integrity as well as reliable as well as adaptable communication.
- Zero On-site testing new functionalities to complete the general test architecture, generic communication model between the different components of the test environment(s) defined, standardized interfaces and simulators to support automated testing in the laboratory.
- Formal Methods towards standardised engineering and operational rules through an open standard interface and a functional ETCS description model.

## 1.4 Outlook for the Europe's Rail JU in Horizon Europe

The research work for advance traffic management and control systems (IP2) in the frame of Shift2Rail H2020 is facing the last projects X2Rail-4 [3] and X2Rail-5 [8], once X2Rail-1 [9], X2Rail-2 [10] and X2Rail-3 [11] come to an end. The results of all the work are paving the way for Shift2Rail successor Europe's Rail Joint Undertaking in the frame of Horizon Europe. This Rail European Partnership will focus on accelerating, with an integrated system approach, research, development and demonstrations of innovative technologies and operational solutions (enabled by digitalization and automation) for future deployment to deliver on European Union policies towards "European Green Deal" objectives "a Europe fit for the digital age", "an economy that works for people" and "a stronger Europe in the world"[12].

Europe's Rail will implement an ambitious research and innovation programme, designed in line with the Sustainable and Smart Mobility Strategy, and delivered by the System and Innovation Pillars, bringing the most advanced technological and operational solutions to rail. Steered by an integrated system approach, implemented with a multi-annual programme enabled by the JU's Members, the new Programme will start delivering major flagship solutions as from 2025-26 to be demonstrated at large scale in the following years, and to bridge the future activities in the post-2028 era [13]. Among the innovation topics that would be covered there are the evolution of operational and business aspects such as [14]:

- Configuration of the new European reference operations framework and architecture for Control, Command and Signalling (CMS).
- Future evolution of the ERTMS system.
- Advances in telecommunications (5G developments with specific railway service and business use cases).
- Traffic management platforms.
- Automation of logistics chain, terminals and freight operations.
- Intelligent rail asset management and maintenance.
- BIM development for use in digital rail twins.

## 1.5 Conclusions

The SmartRaCon Partners are performing research work on innovative technologies for Digitalization and Automation to prepare the ground for new generations of train control and railway management systems. Some of the core elements are technologies covered in the 4th SmartRaCon Workshop 2022 topics, namely On-Board Train Integrity, Traffic Management System and Smart Wayside Object Controllers, linked to X2Rail-4 [3]. In parallel to the technological research, SmartRaCon Partners are developing and operating simulators and research infrastructures as well as carrying out analyses for the validation of the technologies.

To disseminate the results of the scientific work, SmartRaCon organizes the yearly Scientific Seminars to present and discuss their results on a high scientific level. The first SmartRaCon Scientific Seminar took place on the 25th of June 2019 in Villeneuve d'Ascq in France [15], due to the pandemic situation in Europe, the second seminar was held the 24th of November 2020 in a digital format from San Sebastian in Spain [16], and the third seminar, in the #EUYearOfRail, on the 2nd of September 2021 from Braunschweig in Germany [17]. Now, the fourth SmartRaCon Scientific Seminar takes place the 20th October 2022 in San Sebastian, Spain. Finally, to close the SmartRaCon Scientific Seminars in the frame of Shift2Rail, the fifth SmartRaCon Scientific Seminar is expected to take place in 2023 in Germany.

## 1.6 References

- [1] SmartRaCon: Technical Concept. May 2015.
- [2] Shift2Rail Master Plan. Shift2Rail Joint undertaking 1st issue 2015. [www.shift2rail.org](http://www.shift2rail.org).
- [3] X2Rail-4 Advanced signalling and automation system - Completion of activities for enhanced automation systems, train integrity, traffic management evolution and smart object controllers [https://projects.shift2rail.org/s2r\\_ip2\\_n.aspx?p=X2RAIL-4](https://projects.shift2rail.org/s2r_ip2_n.aspx?p=X2RAIL-4)
- [4] IMPACT-2 Indicator Monitoring for a new railway PARadigm in seamlessly integrated Cross modal Transport chains – Phase 2 [https://projects.shift2rail.org/s2r\\_ipcc\\_n.aspx?p=IMPACT-2](https://projects.shift2rail.org/s2r_ipcc_n.aspx?p=IMPACT-2)
- [5] FINE -2 Furthering Improvements in Integrated Mobility Management (I2M), Noise and Vibration, and Energy in Shift2Rail [https://projects.shift2rail.org/s2r\\_ipcc\\_n.aspx?p=fine-2](https://projects.shift2rail.org/s2r_ipcc_n.aspx?p=fine-2)
- [6] LINX4RAIL System architecture and Conceptual Data Model for railway, common data dictionary and global system modelling specifications [https://projects.shift2rail.org/s2r\\_ipx\\_n.aspx?p=LINX4RAIL](https://projects.shift2rail.org/s2r_ipx_n.aspx?p=LINX4RAIL)
- [7] LINX4RAIL-2 System Architecture and Conceptual Data Model For Railway, Common Data Dictionary And Global System Modelling Specifications [https://projects.shift2rail.org/s2r\\_ipx\\_n.aspx?p=LINX4RAIL2](https://projects.shift2rail.org/s2r_ipx_n.aspx?p=LINX4RAIL2)
- [8] X2Rail-5 Completion of activities for Adaptable Communication, Moving Block, Fail safe Train Localisation (including satellite), Zero on site Testing, Formal Methods and Cyber Security [https://projects.shift2rail.org/s2r\\_ip2\\_n.aspx?p=X2RAIL-5](https://projects.shift2rail.org/s2r_ip2_n.aspx?p=X2RAIL-5)
- [9] X2Rail-1 Start-up activities for Advanced Signalling and Automation Systems [https://projects.shift2rail.org/s2r\\_ip2\\_n.aspx?p=X2RAIL-1](https://projects.shift2rail.org/s2r_ip2_n.aspx?p=X2RAIL-1)

- 
- [10] X2Rail-2 Enhancing railway signalling systems based on train satellite positioning, on-board safe train integrity, formal methods approach and standard interfaces, enhancing Traffic Management System functions [https://projects.shift2rail.org/s2r\\_ip2\\_n.aspx?p=X2RAIL-2](https://projects.shift2rail.org/s2r_ip2_n.aspx?p=X2RAIL-2)
  - [11] X2Rail-3 Advanced Signalling, Automation and Communication System (IP2 and IP5) – Prototyping the future by means of capacity increase, autonomy and flexible communication [https://projects.shift2rail.org/s2r\\_ip2\\_n.aspx?p=X2RAIL-3](https://projects.shift2rail.org/s2r_ip2_n.aspx?p=X2RAIL-3)
  - [12] Shift2Rail Successor <https://shift2rail.org/shift2rail-successor/>
  - [13] Renewal of Shift2Rail Executive Director’s mandate <https://shift2rail.org/news/renewal-of-shift2rail-executive-directors-mandate/>
  - [14] Europe’s Rail Joint Undertaking Multi-Annual Work Programme Version 2.0 1 March 2022 [https://rail-research.europa.eu/wp-content/uploads/2022/03/EURAIL\\_MAWP\\_final.pdf](https://rail-research.europa.eu/wp-content/uploads/2022/03/EURAIL_MAWP_final.pdf)
  - [15] SmartRaCon: Proceedings of the 1st SmartRaCon Scientific Seminar. 25. June 2019, Lille, France. Reports from the DLR-Institute of Transportation Systems Volume 35, ISSN 1866-721X
  - [16] SmartRaCon: Proceedings of the 2nd SmartRaCon Scientific Seminar. 2020, 24, November 2020 San Sebastian, Spain. Reports from the DLR-Institute of Transportation Systems Volume 38, ISSN 1866-721X
  - [17] SmartRaCon: Proceedings of the 3rd SmartRaCon Scientific Seminar. 2021, 2, September 2021 Braunschweig, Germany. Reports from the DLR-Institute of Transportation Systems Volume 38, ISSN 1866-721X



## 1.7 Authors



Dr. **Marion Berbineau** received the Engineer degree from Polytech'Lille (France) and the Ph.D. degree from the University of Lille, both in electrical engineering, respectively in 1986 and 1989. She is a full time Research Director at Université Gustave Eiffel in the Component and SYStem department and in charge of coordination of Railway R&I activities of the University. She is associated researcher at LEOST laboratory. She is expert in the fields of radio wave propagation in transport environments (particularly in railway tunnels and high speed lines), electromagnetic modeling, channel characterization and modeling, MIMO, wireless systems for telecommunications, cognitive radio for railways and GNSS localization-based system for ITS particularly for the rail and public transport domains. She is responsible for Railway research coordination for the Institute. She is active as an expert for the GSM-R and future systems like LTE-A or 5G NR and beyond 5G. She is involved in several National and European research projects. She is author and co-author of several publications and patents. She is expert at the French national council for the railway system. She is on the reserve list of the Scientific Council of Shift2Rail.

marion.berbineau@univ-eiffel.fr



**Michael Hutchinson** has over 14 years of experience in the GNSS industry. Michael has developed solutions for and provided consultancy on a wide range of GNSS applications involving robust and reliable positioning and navigation. This includes aviation approach operations, liability critical automotive programmes, future train control systems and Unmanned Aerial Vehicles (UAVs). Michael also provides consultancy on GNSS system level topics. Michael currently works as Business Manager and Principal Navigation Engineer at GMV NSL, coordinating business development activities and leading the company's work in the railway domain.

michael.hutchinson@gmvnsl.com



Dr. **Émilie Masson** is a Project coordinator at Railenium, France. She received the Engineer degree from the Institut Supérieur de l'Électronique et du Numérique, Lille, in 2005 and the PhD degree in electronics from the University of Poitiers, in 2010. She joined Railenium in 2014 as a researcher. She conducted research activities related to telecoms on various European and national projects. She then moved on to become a project manager. Since 2017, she has been coordinating the TC-Rail project, which aims to test the feasibility of railway remote driving. She also coordinates all Railenium activities on Shift2Rail IP2 since 2016.

emilie.masson@railenium.eu



Dr. **Jaizki Mendizabal** received his M.Sc. and Ph.D. degrees in Electrical Engineering from TECNUN (University of Navarra, San Sebastián, Spain) in 2000 and 2006 respectively. He joined Fraunhofer Institut (Nuremberg, Germany) and SANYO Electric Ltd, Japan as RF-IC designer. Nowadays, he is at CEIT, in San Sebastián (Spain) where his research interests include communications and electronic systems. He is lecturing "Communications Electronics" and "Communications via Radio" at TECNUN (University of Navarra).

jmendizabal@ceit.es



Dr.-Ing. **Michael Meyer zu Hörste** holds a PHD in mechanical engineering from the technical University of Braunschweig. He has joined DLR Institute of Transportation Systems in 2001 bringing already 6 years of railway research experience with him. He is expert in railway operations, command, control and signalling systems, especially ERTMS/ETCS as well as train localisation. Currently he is working the business development of the DLR Institute of Transportation Systems He was a major contributor in building the DLRs ETCS test laboratory RailSiTe®. He is chairman of the ERTMS Reference Labs Association since 2012. He is fellow of the Institution of Railway Signalling Engineers (FIRSE) since 2012. He is member of the Shift2Rail and EU Rail governing boards as well as the coordinator in the DLR for Shift2Rail and Europe's Rail.

Michael.MeyerzuHoerste@dlr.de



## 2 Demonstration of Automation and Efficiency: The X2Rail-4 perspective for CCS-Systems of Future

Philippe Prieels, Alstom, Charleroi, Belgium

Michael Meyer zu Hörste, DLR, Braunschweig, Germany

### 2.1 Introduction

In the European Joint Undertaking Shift2Rail are five Innovation Programs from which the IP2 is focussed on “Advanced Traffic Management & Control Systems”. The work is organised in the series of the X2Rail-Projects, from which X2Rail-4 is the fourth project and one of the two final ones [1]. The focus is on research and development of innovations in the following areas: Demonstrating the Automatic Train Operation (ATO) as well as Smart Wayside Object Controllers (SWOC) in real environment, further developing the Onboard Train Integrity (OTI) and finally extending the Time Table Management and Traffic Control (TMS) to integrate new functionalities as e.g. ATO in the optimisation and control strategies to achieve the best impact on the rail operation in order to reduce costs and improve capacity and reliability.

The logo of X2Rail-4 is shown in Fig. 2-1. It is part of a family of logos developed to show the coherency between the five X2Rail-x projects.



Figure 2-1: X2Rail-4 Logo

### 2.2 Objectives

#### 2.2.1 Overall Objectives

The second pillar of the European Joint Undertaking Shift2Rail is the innovation program IP2 “Advanced Traffic Management & Control Systems” which is focussed on control-command and signalling systems (CCS), as well as communication systems. The target is to develop new innovative technologies which enable new functionalities for railway operation. The objective of IP2 is also to expand the level of standardisation. The main challenge is to increase the functionalities of the existing signalling and automation systems as well as the related design and validation processes providing a more competitive, flexible, real-time, intelligent traffic control management and decision support system. Nevertheless, the backward compatibility to the existing European Rail Traffic Management System (ERTMS) and especially its European Train Control System component (ETCS) shall be maintained.

The project X2Rail-4 aims to conclude activities in four of the eleven so-called “Technical Demonstrators (TD)” in the Shift2Rail IP2. It continues and finalises research and development of key technologies to foster innovations in the field of railway traffic control, command &

signalling, and automation. The demonstration of the new technologies as e.g. ATO in real environment is a central task of the project.

The actions undertaken in the scope of X2Rail-4 are related to the following specific objectives:

- On the basis of ERTMS/ETCS to implement (develop and test) the Automatic Driving up to the highest grade of automation GoA4 increasing line capacity, reducing operating costs, saving energy;
- To specify and prototype an innovative On-Board Train Integrity solution, capable of autonomous train tail localisation, wired or wireless communication between the tail and the front cab, safe train integrity supervision (SIL-4 at system level) of train interruption, traditional power supply or energy harvesting solutions without the deployment of any fixed trackside equipment;
- To develop a standardised communication structure linking rail different business services and new software applications for Time Table Management and Traffic Control to support the operation of the new drive modes e. g. ATO;
- To develop and test new concept Object Controllers consisting of a solution scalable and flexible enough to fulfil different configurations and scenarios, where locally derived power and wireless communications, guaranteeing safety and security justifications, together with maximum de-centralisation are applied. Additionally, the higher bandwidths will be used for transmission of status reports / maintenance information and further required data.

The actions undertaken in X2Rail-4 target high readiness level (TRL) starting from the results of previous X2Rail-1, X2Rail-2 and X2Rail-3 projects. The overall concept to fulfil the above-mentioned targets is shown in Fig. 2-2.

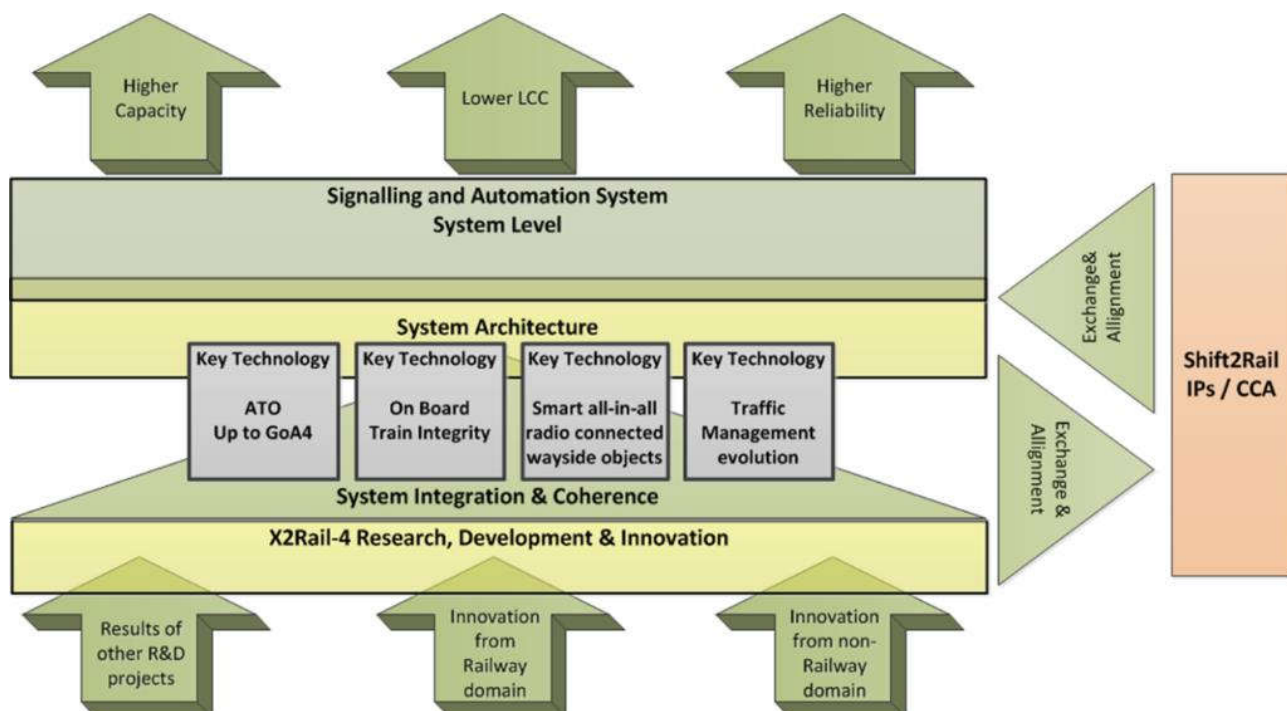

Figure 2-2: Overall concept of the X2Rail-4 project

The four Key Technologies appearing in Fig. 2-2 are further described in the sections below (the number of the Technical Demonstrators (TDx.y) is provided to show how the work done in X2Rail-4 relates to the Shift2Rail IP2 structure):

### **2.2.2 ATO Up to GoA4 (TD2.2)**

Fully automatic train operation (ATO) up to unattended operation in Grade of Automation 4 (GoA4) is a major innovation in the rail system with the aim of:

- Increasing the transportation capacity on existing lines while limiting investment for new infrastructure
- Reducing the operating costs saving energy and having a more efficient use of resources (e.g. staff)
- Improving service and quality to customer: quality of service is enhanced thanks e.g. to a better punctuality (arrival and departure times no more depend on the way the driver drives the train).

This action provides an important contribution to the vision of a fully automated rail system enhancing interoperability on the basis of ETCS specification.

Two aspects are in the focus of the work stream related to ATO over ETCS (AoE) up to GoA4: Updating and finalising the specification as well as testing in the real environment. The first tests are taking place in different laboratories which have been developed or updated and validated for those tests. Afterwards field tests are executed. Several suppliers will develop and provide solutions composing the AoE system. These solutions will be tested in lab and on site.

### **2.2.3 On-Board Train Integrity (OTI) (TD2.5)**

The technical development of the OTI is continued and completed by defining, developing and testing prototypes for the systems for different train topologies (wired solutions that can be implemented in fixed coupled train sets as many passenger trains; wireless solutions that can typically be used on freight trains). Additional activities are carried out with respect to energy harvesting and wireless communication. All the elements of the prototypes are implemented and tested in laboratories. Four different implementations provided by different partners are tested. Finally, the demonstration taking place in the Integrated Technology Demonstrator in X2Rail-5 has been prepared and systems provided.

A couple of activities are completing the technical development: The analysis related to RAMS and especially safety as well as the Cost-Benefit-Analysis are continued from the results of X2Rail-2 and completed with respect to the results achieved in this project. Approaches and concepts for the migration are collected and described. Finally, a proposal for the standardisation and related options are sketched.

### **2.2.4 Traffic Management Evolution (TD2.9)**

Many innovations have been developed to improve the competitiveness of the rail systems. Hence there is the need to reflect those innovations and their resulting impact on operations in

the time table management and traffic control systems. The exchange framework of the integration layer has been designed in earlier projects in Shift2Rail in order to ensure the seamless and fast exchange of information inside the rail system and with external clients and services. There is an improvement of the specification of the integration layer based on the demonstration of innovations as e.g. ATO in this project.

Recent evolutions of technologies as Artificial Intelligence (AI) allow to enrich the TMS with AI-based functionalities to optimise operations with respect to capacity, cost reduction and reliability by adding business logic and decision support tools. The specific prototypes are focussed on the integration of connected driver advisory systems, conflict detection and resolution systems, wayside ATO constituents, integration of field status, asset management and other business logic applications as well as various application modules. This set of different applications or modules is developed and provided by seven partners and tested in the integration layer.

### **2.2.5 Smart all-in-all radio connected wayside objects (TD2.10)**

Cabling is a significant issue for railways as e.g. developed in the project IMPACT-2 [2] for cost as well as for reliability. The consequent solution of Smart Wayside Object Controllers (SWOC) is targeted to develop individual units which are de-centralised up to the level of one unit for every individual trackside object, using locally derived power supply and different wireless connections. The specification of the SWOC provides a highly scalable and flexible solution for different applications, configurations and scenarios. Further aspects as e.g. safety, security and data provision for maintenance and asset management are covered as well. In total eight different SWOC prototypes are developed by different partners and successfully tested and demonstrated in lab and on site.

## **2.3 Methodology**

X2Rail-4 follows a holistic system approach that makes it possible to create and exploit synergies between the technical work streams dedicated to signalling and automation system: Railway line capacity increase (ATO GoA3/4), On Board Train Integrity, Traffic Management Evolution and Smart Radio-connect all-in-all wayside objects. The system approach ensures coherency of all the developments through specification, design, data management, verification, validation and finally demonstration in lab and on site.

The working methodology includes the definition of requirements that are allocated to the different technical work streams, followed by the specification of architectures and interfaces. The specification and development of prototypes include functional system integration, allowing an aggregated proof of concepts by V&V, demonstration, meeting the overall needs of the system development.

To ensure coherence and integration of the results of the four technical work streams, X2Rail-4 has created a dedicated work package (WP2) where technical experts come together to ensure technical coordination and system integration between the work packages. This transversal work package does not only ensure coherence within X2Rail-4 project, but also with the other IP2 projects (X2Rail-1, X2Rail-2, X2Rail-3 and X2Rail-5) and Shift2Rail non-IP2 projects

like Linx4Rail and Tauro. In order to ensure the consistency with the ETCS kernel concept and to facilitate that the outputs from the project will be well prepared to enter smoothly the ERTMS CCM process, the liaison with corresponding EUG and UNISIG groups is also maintained.

## 2.4 Impact

The Shift2Rail project X2Rail-4 supports the rapid and broad deployment of advanced traffic management and control systems, by offering improved functionalities and standardised data and physical interfaces based on common operational concepts, facilitating the migration from legacy systems, decreasing overall costs, adapting it to the needs of the different rail segments as well as to the needs of a multimodal smart mobility system.

### 2.4.1 Improved capacity

ATO up to GoA4 contributes to improving the overall line capacity thanks to train traffic optimisation which contributes to achieving service punctuality and to optimising headway between trains.

The OTI system contributes, as enabling technology for ETCS L3, to implementing advanced Train Separation systems based on self-train integrity detection and localisation (Moving or Fixed Virtual block); it therefore improves line capacity and allows better line exploitation.

The integrated approach of simultaneously developing ATO up to GoA4, Traffic Management Evolution and Smart Radio connect all-in-all wayside objects pave the way for radical new signalling and automation concepts. The management of the line and its performances included the Train Integrity concept significantly increase the capacity of the line.

In addition, TMS Services investigate the application of deep learning algorithms to the railways and specifically to traffic management. This type of algorithms has achieved spectacular results in other highly complex problems. More powerful algorithms enhance the ability to recover from disruptions to train operation by considering more complex scenarios. This increases punctuality and together with ATO contributes to higher capacity on the same infrastructure.

### 2.4.2 CAPEX and OPEX reduction

Making optimal use of railway system capabilities as well as reducing costs is a major objective of Shift2Rail. Consequently, it is to be analysed where higher degrees of automation and digitalisation can help to improve the train operation and reduce costs (CAPEX and OPEX).

Two immediate targets in X2Rail-4 are the reduction of trackside equipment and cabling by OTI, which moves the train integrity supervision into the trains, and SWOC, which exchanges cabling for data and power supply by radio and energy harvesting. Both, investment and maintenance costs, are directly reduced. AoE in collaboration with an adapted TMS addresses a number of cost positions as e.g. reduction of energy consumption by optimised operation, less maintenance cost for brakes and other mechanical parts thanks to an optimised driving and a more efficient use of the resources (e.g. staff) . Finally, the TMS including the integration layer reduces cost for installation and updates. Standardisation of the frameworks, data



structures and interfaces within the Integration Framework and Application Layer contribute to delivering a reduction of the investment for new integrated installations.

### **2.4.3 Reduction of environmental impact**

A major impact of the optimised operation using a well-adjusted combination of AoE GoA4 and TMS is a reduction of energy consumption and consequently a reduction of emissions e.g. carbon dioxide or noise (thanks to optimised driving with less acceleration and braking phases) which is an immediate increase in sustainability.

The application of the SWOC is also providing a positive environmental impact by reducing the need of concrete and civil works e.g. for cable trays as well as a reduction of carbon emissions by local energy harvesting systems.

### **2.4.4 Enhancement of the overall reliability, safety and security**

For instance, the work under TMS services provides an increase of transport reliability through application of new artificial intelligence and optimisation methods in TMS. Traffic Management Evolution also contributes to improving reliability of train operations in terms of service and availability of wayside assets through automation of processes and improved decision-making processes. It also contributes to allowing, through the new communication platform, the integration of now and forecasted status data of scheduled train services, infrastructure assets, rolling stock and information from external clients and services into Traffic Control, Traffic Management and other services processes. This secures the delivery of the production time table to reduce delays hence improving reliability of train services and availability of assets. All innovations from X2Rail-4 are developed in the European Framework and hence applying the current approaches for safety, security and standardisation in Europe.

## **2.5 Conclusion**

The project X2Rail-4 is one of the two final projects in the X2Rail-Series of five projects and finishes four TDs. The focus is on development and demonstration in laboratory and field of innovations in the four areas. Several different prototypes for automatic train operation over ETCS will be implemented and demonstrated in dedicated tests to show the maturity of the solutions as well as the interoperability and interchangeability of these solutions. Four prototypes for wired or wireless onboard train integrity supervision have been developed and tested to show the applicability for different train architectures and scenarios. The evolution of the Traffic Management has been successfully demonstrated by a significant number of different applications, which were tested the using integration layer. With the target to reduce investment and maintenance cost for cabling smart all-in-all radio connected wayside objects have been developed. In total eight different prototypes for different applications have been demonstrated successfully and have so proven the scalability and flexibility of the approach of the SWOC. The X2Rail-4 project is performing the final activities of four TDs of IP2. The X2Rail-5 project is performing the final activities of six other TDs (the eleventh TD of IP2 was already closed in the frame of X2Rail-3). Nevertheless, innovations for rail automation and signalling as well as for rail traffic management are two of the large flagship areas in the new EU-Rail JU that will continue innovation in the domain of rail automation.

## 2.6 References

- [1] X2Rail-4: [https://projects.shift2rail.org/s2r\\_ip2\\_n.aspx?p=X2RAIL-4](https://projects.shift2rail.org/s2r_ip2_n.aspx?p=X2RAIL-4)
- [2] IMPACT-2 (GA No.: 777531) Deliverable 4.6 Iterative SPD integrated assessment

## 2.7 Acknowledgements

The project X2Rail-4 has received funding from the Shift2Rail Joint Undertaking (JU) under grant agreement No. 881806. The JU receives support from the European Union's Horizon 2020 research and innovation programme and the Shift2Rail JU members other than the Union.

Disclaimer: This dissemination of results reflects only the authors' view and the Shift2Rail Joint Undertaking is not responsible for any use that may be made of the information it contains.



## 2.8 Authors



Ir. **Philippe Prieels** holds a Master's degree in Electrical Engineering from the UMONS Faculty of Engineering (FPMS, also known as "Polytech Mons"). He joined Alstom Belgium s.a. in 1996. He is working on Control-Command and Signalling for Railway since then and on ERTMS/ETCS related topics since 1998. He is contributing to the European collaborative projects for 15 years. In 2007, he joined the UNISIG Super Group. He led twice this group. He then joined Shift2Rail in 2019 with a double responsibility: leader of the X2Rail-4 project, one of the five projects of Shift2Rail Innovation Programme number 2 (IP2), and leader of the transverse "Technical Coordination & System Coherence" Work Package of this IP2. He is also representing Alstom in the Steering Committee of the IP2 as well as in the Steering Committee and the Technical Management Team of various Shift2Rail projects. He is now also coordinating the Alstom participation to the Flagship Area number 2 of Europe's Rail JU Innovation Pillar. He is recognised as a Senior Expert within Alstom.

E-Mail: [Philippe.Prieels@alstomgroup.com](mailto:Philippe.Prieels@alstomgroup.com)



Dr.-Ing. **Michael Meyer zu Hörste** holds a PHD in mechanical engineering from the technical University of Braunschweig. He has joined DLR Institute of Transportation Systems in 2001 bringing already 6 years of railway research experience with him. He is expert in railway operations, command, control and signalling systems, especially ERTMS/ETCS as well as train localisation. Currently he is working the business development of the DLR Institute of Transportation Systems He was a major contributor in building the DLRs ETCS test laboratory RailSiTe®. He is chairman of the ERTMS Reference Labs Association since 2012. He is fellow of the Institution of Railway Signalling Engineers (FIRSE) since 2012. He is member of the Shift2Rail and EU Rail governing boards as well as the coordinator in the DLR for Shift2Rail and Europe's Rail.

E-Mail: [Michael.MeyerzuHoerste@dlr.de](mailto:Michael.MeyerzuHoerste@dlr.de)

## 3 Quantitative Safety Requirements of the New Onboard Train Integrity Function

*Insaf Sassi, IRT Railenium, Famars, France*

*El-Miloudi El-Koursi, COSYS-ESTAS, Université Gustave Eiffel, IFSTTAR, Université Lille, France*

*Joffrey Clarhaut, Université Polytechnique Hauts-de-France, Valenciennes, France*

*Dominique Renaux, Université Polytechnique Hauts-de-France, Valenciennes, France*

*Julie Beugin, COSYS-ESTAS, Université Gustave Eiffel, IFSTTAR, Université Lille, France*

### 3.1 Introduction

The objective of this work is to determine the safety requirements of the Onboard Train Integrity OTI based on the infrastructures managers (IMs) data analysis and Moving Block (MB) work package assumption of SIL4 safety requirement, at system level. The aim is to provide a safety analysis to set OTI safety requirements, to comply with TD2.5 objectives in X2Rail-2 [8] and X2Rail-4 [9]. A harmonized approach to define a common safety requirement (SIL 4 at system level) and to contribute to standardization for OTI is proposed. Inside X2Rail-4 WP6, a working group was constituted to work on the safety analysis of the OTI in order to justify the safety requirement to be set based on field data of the train separation event occurred in the last 10 years provided by DB, NR and SBB in addition to 4 years of data provided by ÖBB. The safety analysis addresses two types of trains: passenger and freight. Consequently, the safety requirements of the OTI are defined by train type. The data are provided as accident and near miss statistics, related to the risk of undetected loss of train integrity i.e., undetected unintended train separation. Other data related to the number of trains per day and the operating time (per unit or total) are also given to quantify the OTI safety requirements per unit i.e., train.

### 3.2 Onboard Train Integrity

The on-board train integrity (OTI) system is designed to safely monitor the completeness of the train in operation. Consequently, train integrity monitoring and detection of unintended train separation are the responsibility of the onboard system and not the trackside equipment (track circuit, axle counters) anymore. In case of loss of integrity, i.e., unintended train separation, the OTI must detect it and report it to the ETCS onboard unit. The train integrity monitoring system supervises the status of the train tail by checking the coherence of the last wagon movement. In fact, the last wagon must be regularly advancing with the head of the train. The integrity status information must be provided to the ETCS onboard as shown in Figure 3-1 and then transmitted to the Radio Block Centre (RBC). It has three possible values: confirmed, lost or unknown according to CR940 [6].

The train integrity monitoring system consists of the following modules as depicted in Figure 3-1:

- OTI Slave (OTI-S): It is the tail OTI device. It communicates the status data of the train tail to the OTI Master.

- OTI Master (OTI-M): It is the head OTI device. It acquires the information of train integrity status from the OTI-S (intermediate and tail), evaluates it and sends it to the ETCS onboard.
- OTI Intermediate Slave: It is the OTI-S non tail which is an intermediate device installed along the vehicle. In fact, an OTI slave at train tail changes its position while adding other wagons after coupling procedure. In this case, it does not contribute to the train integrity status evaluation in case of product class 1 and 2. After the intentional splitting procedure, an intermediate slave identifies its position as slave in tail and contributes to the train integrity evaluation. However, in case of product class 3 (see definition below), the intermediate OTI slaves contribute to the evaluation of the train integrity status by determining the distance between adjacent OTI devices.
- Communication Network: It is the communication channel for information exchanging among OTI monitoring system devices. It can be wired or wireless and is bidirectional between the OTI modules.

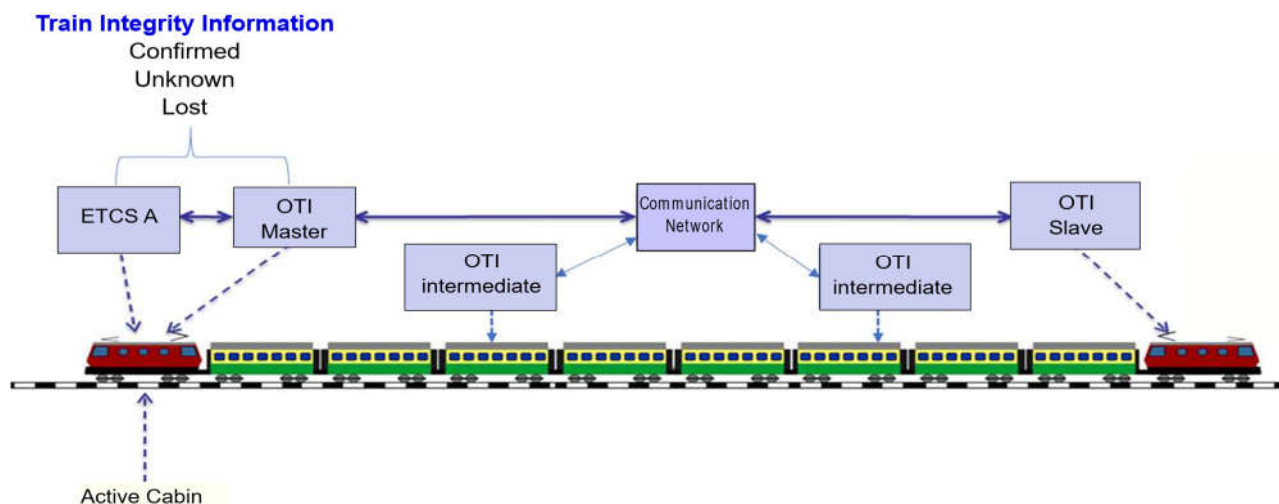

Figure 3-1: Onboard train integrity architecture

The way the integrity is evaluated depends on the technology used for the communication among the OTI modules and the train type (passenger or freight). Consequently, three classes of OTI are defined and hence the integrity criteria. Product class 1 refers to train with wired communication network where the integrity is evaluated based on the communication liveness between the OTI-S in tail (last waggon) and the OTI-M, head of the train. Product class 2 refers to trains equipped with wireless communication technology. In this case, the integrity is determined based on comparing kinematic data of train tail and front cabin (e.g., position, speed, acceleration). For Product Class 3, where OTI modules are installed in each waggon, train integrity criterion consists in verifying separation distance between adjacent waggons. More details about the OTI specifications can be found in Deliverable D4.1 [5] of X2Rail-2 WP 4. In addition to the onboard system as defined in Figure 3-1, OTI of product class 2 and 3 have more specifications by integrating the traffic management system (TMS), in the start of mission (SoM), in the first stage procedures, needed to evaluate the train integrity. Regarding product class 2, the wireless communication cannot enable to perform a safe inauguration process to discover the OTI modules installed along the train and to detect the OTI-S in tail. Therefore, the

inputs from TMS are needed to ensure a safe train integrity monitoring. For product class 3, TMS provides data about the planned train composition and train length used to be compared with the discovered composition and length by the onboard.

## 3.3 OTI safety analysis

### 3.3.1 Analysis approach

The OTI is an onboard function that monitors the completeness of the train continuously while the train is in operation, independently from the trackside infrastructure. Consequently, implementing the train integrity monitoring function onboard shift the safety responsibilities and requirements to the onboard which must meet the safety requirements as stipulated in the railway safety standards i.e. CENELEC 50126 (2017) [1] and the European regulation (402/2013) on common safety methods (CSM) [2]. In fact, the train integrity must be guaranteed by fulfilling a SIL 4 (Safety Integrity Level 4) requirements obtained as an overall result at system level, independently from trackside infrastructure. Note that according to Subset-026 [7], train integrity shall consist of train integrity status information, which is the objective of this analysis, and safe train length information for Level 3. As a new system to detect loss of train integrity, the OTI must offer a level of safety as least as good as the one offered by any equivalent system at the railway system level. The explicit risk estimation is considered to define the safety requirements of the OTI.

The OTI is considered as a safety function that is used as a detection mechanism of the unintended train separation. So, an undetected unintended train separation is the consequence of train coupling failure i.e., unintended train separation, and the failure of the OTI to detect it. In fact, hazard 2 "OTI evaluates incorrectly the train integrity as confirmed" in combination with the hazard 1 "unintended train separation" represents a hazardous situation that leads to train collision as depicted in Figure 3-2. These two independent and correlated functions can be considered autonomous according to the standard EN50126 (2017) part 2.

Explicit risk estimation is chosen as risk acceptance criteria (RAC) to determine the THR of "incorrect train integrity status information is leading to accident" as recommended in the CSM [2]. Note that the failure of the OTI does not lead directly to accident that requires the simultaneous failure of the OTI and the train coupling. So, the considered technical system is a mix of Electrical/Electronic/Programmable Electronic (E/E/PE) part which is the OTI and the mechanical and/or pneumatic part which is related to the train coupling. The non-detection of the unintended train separation has the potential to lead to collision accident affecting a large number of people and there is a potential for multiple fatalities. According to CSM, the severity class that can be considered is "catastrophic". Thus, the tolerable hazard rate of  $10^{-9}$  /h is allocated to the top hazard of "incorrect train integrity status information is leading to accident" which represents the event of misdetection of loss of integrity. The defined tolerable hazard rate ( $THR_0$ ) can then be apportioned to the contributing parts i.e., hazard 1 ( $THR_1$ ) and hazard 2 ( $THR_2$ ) of the fault tree of Figure 3-2.

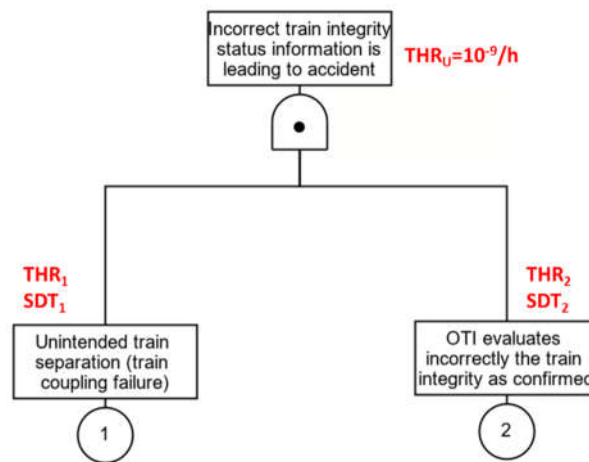

Figure 3-2: Fault Tree of undetected unintended train separation

In the objective of defining the safety requirements of the OTI, a quantitative approach based on the Fault Tree analysis (FTA) is proposed as depicted in Figure 3-2. It consists in apportioning the top event Tolerable hazard rate  $THR_u=10^{-9}/h$  and applying a quantitative analysis to evaluate the  $THR_2$  related to the failure of the OTI to detect the loss of integrity. The apportionment of  $THR_u$ , in the fault tree of Figure 3-2 starts with applying logical combinations of the functions through logical gate AND.

The  $THR_u$  is apportioned based on equation 1 using an "AND" gate according to the standard EN50126 (2017) part 2 [1]:

$$THR_u = THR_1 \times SDT_1 \times THR_2 \times SDT_2 \times \left( \frac{1}{SDT_1} + \frac{1}{SDT_2} \right) = THR_1 \times THR_2 \times (SDT_1 + SDT_2) \quad (\text{Eq.3- 1})$$

Where:

- $THR_u$  is tolerable hazard rate for train integrity,
- $THR_1$  is tolerable hazard rate for train coupling,
- $SDT_1$  is Safe Down Time of train coupling,
- $THR_2$  is tolerable hazard rate for OTI,
- $SDT_2$  is Safe Down Time OTI.

The Safe Down Time (SDT) (or the "Safe Down Rate" (SDR) with  $SDR=1/SDT$ ) is defined as the mean detection and negation time of functions failure and can be set to the testing period. Furthermore, the independency must be proven through the logical gate AND which is the case for the OTI which acting as independent detection mechanism for the train coupling failure (see EN50126 (2017), part 2).

The first step of the quantitative approach consists in determining  $THR_1$  based on IMs data about train separation events related to broken coupling or wrong adjusted draw hook. The numbers recorded in the period of the analysis include the known separation events reported in compliance with requirements of the appendix B of CENELEC standard EN50126, noting that "THR cannot be calculated from accident statistics unless rigorously collected statistics models

are available". To assign the obtained value of  $THR_1$ , based on the actual frequency of occurrence of unintended train separation, the accident statistics provided by DB, NR and SBB over 10 years have been analysed. In addition, ÖBB data provided statistics about unintended train separation recorded between 2015 and 2018.

The  $THR_1$  of the train coupling failure is calculated, per train, as follows:

$$THR1(\text{per train}) = \frac{N_{TS}}{N_{unit} \times H \times N_{years}} = \frac{N_{TS}}{T_{operating} (\text{per year}) \times N_{years}} \quad (\text{Eq. 3-2})$$

Where:

- $N_{TS}$  is the number of dangerous failures i.e., trains separation that have occurred during the years of recording across the railway network.
- $N_{unit}$  is the number of trains in the railway network to calculate the average hazardous failure rate per train
- $H$  is the number of train operational hours per year
- $N_{years}$  the number of years where the train separation events have been recorded
- The quantity  $N_{unit} \times H$  is equal to the yearly total operating time ( $T_{operating}$ ) of all trains in a year
- $\frac{N_{TS}}{N_{years}}$  corresponds to the average yearly number of train separation.

In case of using the worst case of number of unintended train separation in a year, over the period of recorded data, the formula of (Eq. 3-2) can be updated, taking into consideration the maximal number of yearly train separation events, as follows:

$$THR1(\text{per train}) = \frac{N_{TS/year-max}}{N_{unit} \times H} = \frac{N_{TS/year-max}}{T_{operating} (\text{per year})} \quad (\text{Eq. 3-3})$$

Where:

- $N_{TS/year-max}$  is the maximum number of dangerous failures i.e., unintended train separation events, that have occurred in a year, over the years of recording across the railway network.

Note that the IMs have provided either the operating hours per train ( $H$ ), the total operating time of all trains  $T_{operating}$  or the total traced trains kilometres. However, these quantities could be deduced regarding the available inputs.

### 3.3.2 OTI safety requirements

A first step consists in determining the  $THR_1$  related to the hazard "unintended train separation" and is described in the sequel. A set of data has been provided by the IMs in order to proceed with the safety analysis. For every IM data,  $THR_1$  values are determined and the



worst-case value of  $THR_1$  is thereby fixed for freight and passenger trains as explained in the sequel.

Table 3-1 Recap of collected IMs data

DB	NR	SBB	ÖBB
Recorded train separations 2010-2019	Recorded train separations 2011- mid 2020	Recorded train separations 2010- mid 2020	Recorded train separations 2015-2018
Number of trains per type: passenger trains (regional, long distance), freight	Number of trains per type: passenger trains, freight	Number of trains per type: passenger trains (regional, long distance), freight	--
Total traced distance in Km and average speed	Total transit hours for freight trains and passengers (2019-2020)	Total traced distance in Km and average speed	Total traced distance in Km

The safety analysis conducted to allocate THR to OTI function addressed two types of trains: passengers trains and freight according to the accidents and the near miss data available. The study focuses on the analysis of provided data by DB, NR, SBB and ÖBB related to unintended train separation events and the explicit risk estimation to define the safety requirements of the OTI. All the safety analysis concludes that the THR related to "unintended train separation" can be attributed for freight trains around  $2.16 \times 10^{-5}/h$  and around  $6.98 \times 10^{-6}/h$  for passengers' trains. The preliminary results regarding the safety requirements of the OTI are shown in Table 3-2 assuming and considering that:

- All recorded unintended separation events are considered as potentially serious.
- OTI function and train coupling shall be fully independent.
- Values of OTI safety requirements in terms of THR are proposed in Table 3-2 according to the chosen SDT. Operational rules shall be defined to fix SDT values. SDT1 (for train coupling) can be set to some seconds, the time needed to detect a loss of integrity and report it to Radio Bloc Center (RBC) in case immediate actions are taken to reach a safe state after the train separation. SDT2 can be set to the value of the testing period of the OTI.

The preliminary results regarding the safety requirements of the OTI are shown in Table 3-2 as follows, considering the higher SIL for the standardization:

Table 3-2: OTI safety requirement

SDT1 (train coupling)	SDT2 (OTI)	THR2 (passengers trains)	THR2 (freight trains)	SIL (OTI)
<b>SDT1 some seconds (e.g. 10 s)</b>	SDT2=1 h (hourly testing)	$3,82 \times 10^{-4}/h$	$1,42 \times 10^{-5}/h$	SIL1
	SDT2=10 h (in the end of every daily mission)	$3,83 \times 10^{-5}/h$	$1,43 \times 10^{-6}/h$	SIL1
	SDT2=24 h (daily testing)	$1,59 \times 10^{-5}/h$	$5,96 \times 10^{-7}/h$	SIL2
	SDT2=30h (daily testing)	$1,28 \times 10^{-5}/h$	$5,00 \times 10^{-7}/h$	SIL 2

### 3.4 Related works

Several works tackled the safety analysis of the train integrity monitoring system. The document of ERTMS Users Group (EUG) [3] provided information about the Train integrity monitoring (TIM) function requirements from ProRail. The work stated that the probability of loss of train integrity is small i.e., it is around  $10^{-5}$  or  $10^{-6}$  and that SIL4 is not required for the TIM. In fact, according to [3], the unsafe failure rate of the TIM device, i.e. the probability that the TIM device reports “train integrity confirmed” for a certain time ( $T_0$ ) while the train was broken shall be less than  $10^{-5}$ . However, the analysis in [3] includes only functions failure rate without considering detection and negation time (SDT) in the calculations as recommended by standard EN50126 (2017) [1]. Another analysis [4] has been proposed by University of Braunschweig during the workshop safetech 2020 providing different approaches to determine the safety requirements of the TIMS. In the objective of determining the OTI safety targets, this work proposes an explicit risk estimation to quantify the THR related to “unintended train separation”, inputs from SBB are provided about this hazard occurrence frequency in a period of 12 years (2003-2015). The same work proposed other approach based on Markov chain by analytically determine the failure rate formula of the OTI as a function of the failure rate of the train coupling determined using SBB and ÖBB data as explained before. A value of  $\lambda_{TIMS} = 2,15 \times 10^{-5}/h$  is obtained. Another approach is proposed by the same work [4] using Petri Nets and Monte Carlo simulation obtaining a failure rate of  $10^{-3}/h \leq \lambda_{TIMS} \leq 3 \times 10^{-3}/h$  by concluding that the OTI shall be SIL 1, if not SIL 0.

### 3.5 Conclusion

The aim of the safety analysis conducted in X2Rail-4 WP6 is to allocate SIL “safety integrity level” to onboard train integrity OTI function by addressing two types of trains: passengers trains and freight according to the available accidents and near miss data. The study focuses on the analysis of the provided data by DB, NR, SBB and ÖBB related to unintended train separation events and the explicit risk estimation to define the safety requirements of the OTI. The most constrained (higher) SIL is chosen in order to cover the railways applications concluding that the OTI shall be SIL 2.

## 3.6 References

- [1] EN50126 Railway Applications (2017)- The Specification and Demonstration of Reliability, Availability, Maintainability and Safety (RAMS) - Part 2: Systems Approach to Safety
- [2] Common safety method for risk evaluation and assessment and repealing regulation (ec) 352/2009, document regulation (eu) 402/2013, 30th commission implementing regulation (April 2013)
- [3] Report on Request for Information on ERTMS Cold Movement Detection and ERTMS Train Integrity Monitor, ERTMS USERS GROUP (EUG), June 2015.
- [4] Zugtrennung, Prof. Dr.-Ing. Dr. h.c. mult. Eckehard Schnieder, safe.tech 2020 –
- [5] Deliverable 4.1 Train integrity concept and functional requirements specifications. Shift2Rail, X2RAIL-2 WP4 project, August 2020.
- [5] CR940 (2017). Modifications related to train integrity functionalities-14.06.2017
- [6] SUBSET 026 ERTMS/ETCS - System Requirement Specification – rev. 3.6.0
- [7] X2Rail-2 D4.1 Train Integrity Concept and Functional Requirement Specification V5.0, 2020.
- [8] X2Rail-4 D6.1 Results of feasibility studies and laboratory tests for candidate technologies selection and adaptation of existing solutions, 2020.

## 3.7 Acknowledgements

The project X2Rail-4 has received funding from the Shift2Rail Joint Undertaking (JU) under grant agreement No. 881806. The JU receives support from the European Union's Horizon 2020 research and innovation programme and the Shift2Rail JU members other than the Union.

Disclaimer: This dissemination of results reflects only the authors' view and the Shift2Rail Joint Undertaking is not responsible for any use that may be made of the information it contains.



## 3.8 Authors



Dr. **Insaf Sassi** has received the engineering degree from the National School of Computer Sciences (ENSI), Tunisia, in 2014; the master's degree in control systems from Ecole Centrale Lille, France, in 2014; and the Ph.D. degree in control systems from University of Grenoble Alpes in 2017. She joined Railenium as post-doctoral fellow in 2018 and then as safety research engineer to work on RAMS analysis. Her research deals with dependability and safety analysis of railways systems. She contributed in X2Rail-2 WP4, X2Rail-2 WP3, and X2Rail-4 WP6 and WP7 projects.

E-Mail: [insaf.sassi@railenium.eu](mailto:insaf.sassi@railenium.eu)



Dr. **El-Miloudi El-Koursi** is a Research Director at Université Gustave Eiffel (ex IFSTTAR). He has 30 years experiences in performing assessment and certification of safety related rail and associated systems. He obtained in 1985 his Ph.D in Automatic control and industrial computer sciences at University of Lille. In recent years, he has been involved in various European projects. He was the leader of European FP5, SAMNET "Safety Management and interoperability thematic network" thematic network. He is the vice chairman of EURNEX.

E-Mail: [el-miloudi.el-koursi@univ-eiffel.fr](mailto:el-miloudi.el-koursi@univ-eiffel.fr)



Dr. **Joffrey Clarhaut** received his Ph. D in automation and computer science from the University of Lille (France) in March 2009. He is currently an assistant professor at the Polytechnic University of Valenciennes. His research interests include the dependability evaluation of complex systems, particularly during the design phase with an additional concentration for transportation systems.

E-Mail: [Joeffrey.clarauht@uphf.fr](mailto:Joeffrey.clarauht@uphf.fr)



Dr. **Dominique Renaux** got a PhD degree in automation and computer science from the University of Lille in France in 1989. She is now a researcher at the University Polytechnique Hauts-de-France of Valenciennes. Her research project is about dependability parameters assessment of complex systems and SIL Safety Integrated Level evaluation. She works in partnership with IFSTTAR (French Institute of Science and Technology of Transport, Planning and Networks) and RAILENIUM, which objectives are to improve the railway system and the future train's performance. The aim of this ongoing research is to develop methodology to ensure onboard train integrity.

E-Mail: [Dominique.renaux@uphf.fr](mailto:Dominique.renaux@uphf.fr)



Dr. **Julie Beugin** received the engineering degree from National School of Engineering for Computer Science, Automation, Mechanics and Electronics (ENSIAME), in 2002; the master's degree in automation engineering from University of Valenciennes, France, in 2002; and the Ph.D. degree in automation engineering in 2006. Since 2007, she has been with Université Gustave Eiffel (ex IFSTTAR) as a researcher. Her research interest deals with dependability and safety evaluation of complex guided transportation systems. Part of her activities addresses RAMS demonstration issues of GNSS-based solutions embedded in train control applications. She participated to the GaLoROI, STARS, ERSAT-GGC European projects. She has secondment agreements with Railenium to participate to projects in her research fields and with Certifer to realize ISA missions.

E-Mail: [julie.beugin@univ-eiffel.fr](mailto:julie.beugin@univ-eiffel.fr)

## 4 Laboratory Simulation for On-Board Train Integrity

*Gorka De Miguel Aramburu, David Izquierdo Calzada, Jon Goya Odriozola, Jaizki Mendizabal Samper; CEIT, San Sebastián, Guipúzcoa, Spain*

### 4.1 Introduction

On-board Train Integrity (OTI) is the function responsible for verifying the completeness of the train permanently, while the train is in operation. As part of the Innovation Programme 2 of Shift2Rail, Technical Demonstrator (TD) 2.5 deals with an innovative onboard train integrity solution, capable of safe detection of train interruption without the deployment of any fixed trackside equipment.

To increase the capacity and reduce the maintenance costs, especially for freight and low-density mixed-traffic lines, it is essential to implement the OTI functionality. This will enable the use of more efficient signalling systems based on concepts such as Moving Block or Train Position, calculated by the equipment on-board the train, allowing to simplify the fixed wayside infrastructure. Moreover, for this simplification of the trackside equipment to be feasible, the on-board train integrity shall fulfil a SIL-4 safety integrity level at a system level.

One of the techniques used for Train Integrity Monitoring is head and tail length detection. If the movement detected in the head is coherent with the movement detected in the tail, and the length of the train remains inside some boundaries calculated by using the real train length and some thresholds for the measuring equipment, there is no Train Integrity Loss detection.

When Train Integrity Loss occurs, one or more coaches of the train have been unhooked from the rest of the coaches in the train, and so there will be an increase in the train length, an increase in the distance between coaches, and finally, an incoherence between the movement of the head and the tail of the train. These effects shall be monitored by the On-board Train Integrity (OTI) equipment.

In cases where there is a Train Integrity Loss, the On-board Train Integrity (OTI) system should detect the anomaly, indicating the possibility that the train is no longer complete, namely, that one or more vehicles have been separated from the train. If a Train Integrity Loss occurs and it is not detected, an unexpected coach appears on the line, being an obstacle for the normal operation, which could be dangerous for the safe operation. This hazardous situation shall be reported to the signalling system in command of the operation by means of the ETCS onboard unit.

In X2Rail-4 WP6 and WP7, the creation of the OTI devices along with simulators for zero on-site testing has been carried out.

Moreover, this investigation could help to find dual-use technologies that can be applied to every coupling and decoupling operation, and not only when the train interruption is accidental. Demonstration of WP6 and WP7 results achievement will be obtained with laboratory tests on

prototypes and on-field demonstrators, aimed at verifying and demonstrating the right technical choices and to allow the performance analysis. As a relevant part of the laboratory tests, specific models and simulation tools will be adopted thus verifying in advance the performances and the suitability of some specific solutions as well as predicting and analyzing specific behaviors that could be observed in a more complex way at a system level.

As part of the development and validation process of the OTI functionality carried out in WP6 and WP7 of X2Rail-4, a simulator is shown in this work.

## 4.2 On-Board Train Integrity Simulator

A simulator is proposed at the phase of the validation of the system to virtually test the OTI device functionality. The simulator used in this project is based on CEIT's RANSS (Railway Advanced Navigation Simulation System) (see Figure 4-1).

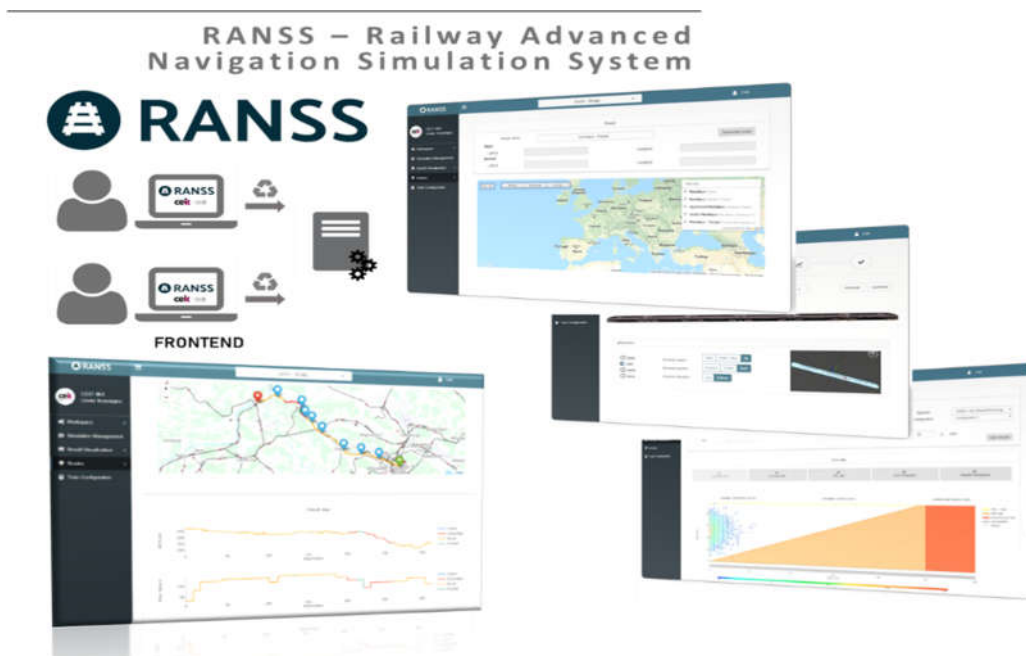

Figure 4-1: RANSS Simulator

The RANSS simulator is extended with a train integrity module to test the train integrity functionality. The simulation-based validation approach of the train integrity module consists of four different sequential steps (Figure 4-2).

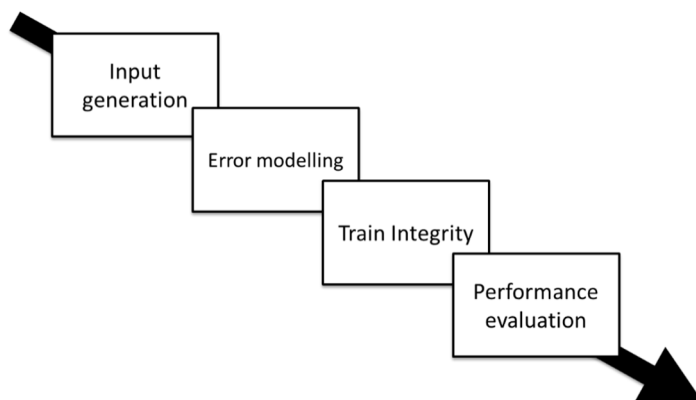

Figure 4-2: Simulation-based validation approach

**Input generation:** Generation of head/rear position information of the train linked to a determined technology on a given track is obtained. That is, the position and the speed of the train head and rear are obtained along the time of the journey. On one hand, there will be the reference data, the one that is supposed to be the real one, and on the other hand, there will be all the data calculated with different technologies such as GNSS (Global Navigation Satellite System) or IMU (Inertial Measurement Unit), employed as an information source by the OTI device.

**Error modelling:** As each of the technologies has different weaknesses and errors, error modelling has to be done. These errors will determine the precision of the selected technology. The considered technologies are:

- GNSS: it is the most straightforward solution. A Global Navigation Satellite System as GPS or Galileo will give the possibility to know the exact position of each coach of a determined train and even compare it with other coach's position so that it is ensured that train integrity is preserved. It fits both the technical and the energy harvesting constraints. The main drawback of the system may be the fact of being a satellite-dependent choice, as occasionally tracks go through tunnels or urban canyons and the lack of coverage could provide misleading results.
- Wired communication: It is the simplest method. Just a wired solution for knowing if the integrity is fulfilled or not by connecting the rear and head coaches.
- Wireless communication: a subdivision is done into terrestrial wireless technologies, including options such as mobile cellular networks (LTE) the 802.11 family, technologies such as ZigBee® and 6LoWPAN (802.15.4), and solutions based on WiMAX (802.16).
- IMU: an IMU or Inertial Measurement Unit as the accelerometer providing acceleration data of each coach could also be used to solve the train integrity problem. The acceleration measured by the odometer will provide the tool to measure Train Integrity (TI): speeds (obtained from the accelerations) of all the different coaches will be compared and gaps will be evaluated. It is also worth mentioning that its low noise features fit perfectly for train vibration detection.
- Train Composition Sensors: this solution consists of proximity sensors in each wagon so that it could know if there are more coaches before and after itself. All this information will be sent to the head coach and there the integrity of the train will be determined.

**Train integrity function:** Once error modelling is done, the next step is train integrity determination. All the data collected in the previous step have to be used and tested with a threshold for each technology. This threshold will be responsible for determining if there is a train integrity issue by testing if the data passes the defined threshold at each instant of time for each method. This third step must be also done with the reference data so that it is ensured that the data simulated for the train integrity is consistent with the reality. This will be the tool to determine the output of the train integrity monitoring function. In fact, there will be four



possible outputs for each method: a correct Train Integrity Loss detection, an undetected Train Integrity Loss, a correct confirmation of Train Integrity, and an incorrect detection of Train Integrity Loss, when there is no real Train Integrity loss, due to the weaknesses of the technology used. With all these parameters the train integrity monitoring capability of a determined technology will be completely represented.

**Performance evaluation:** Performance evaluation and comparison of all the technologies in different tracks and conditions. This will be done through the final result of the simulator module implemented on RANSS. Through this module, there will be the possibility to select different technologies and compare their Train Integrity detection success percentage and all their results through a track.

### 4.3 Test Plan

To test the performance of the developed simulator and to generate a zero on-site testing scenario, the trial site used by Hitachi STS in Tuscany has been modelled. For that, different parameters of the testing environment must be taken into account. The first parameter is the track. Using a public database, RANSS is able to model the track and the environment in which it is. In this case, it is placed in Tuscany and more details are introduced in a later stage. The second parameter is the fact of having introduced a Train Integrity Loss on the reference data or not, that is, if there is a Train Integrity Loss in reality.

The track chosen for doing the tests, and so the one that is simulated is the one between Empoli and Chiusi. In this case, as the journey between those locations is long and has many stations in the way, the track has been split into two parts to make simulations computationally less demanding; one between Empoli and Siena, and another one between Siena and Chiusi (See Figure 4-3 and Figure 4-4).

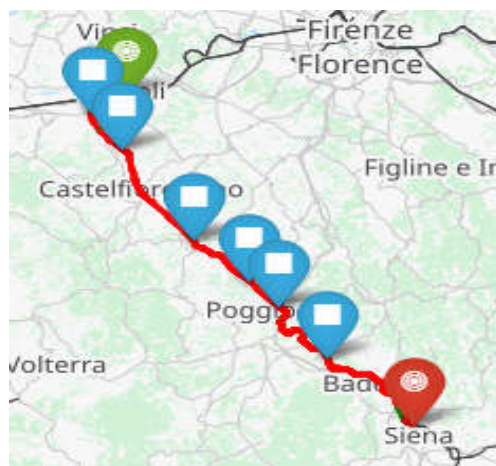

Figure 4-3: Track between Empoli and Siena

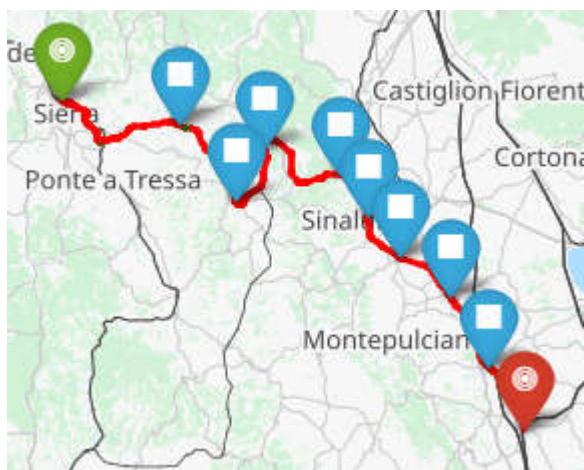

Figure 4-4: Track between Siena and Chiusi

The next step is to configure the train that will be used in the track above. Nevertheless, the process of the formation of the train, as well as the different Train Integrity determination strategies available in the simulator, are always the same. Regarding the formation, the reference vehicle, in this case, is the ALN668 Series 3200. The weight, the length, the width, and the height of each of the coaches, along with the braking forces are included. The complete distribution of these vehicles through the train and their number is also included. So, in this case, the train can be composed of 2 or 3 coaches all of them of the same type.

Finally, the integrity criteria used by the demonstrator has to be known to simulate the integrity of the train along the track with the same criteria of the demonstrator and to test it in fair conditions.

## 4.4 Conclusions

On-board Train integrity functionality is one of the enablers for the future railways allowing to remove track-side equipment and the deployment of the moving block concept. Different solutions might be deployed depending on the railway domain. However, all the solutions will need to go through a development and validation phase. In this context, a simulator for the OTI functionality is proposed based on CEIT's RANSS simulator. By means of the 4 steps of the OTI functionality simulator, it is possible to assess the performance of the proposed OTI functionality solution. The 4 steps are input generation, error modelling, train integrity function, and performance analysis. The simulator covers the scenario generation, different technologies that can be combined including its errors, the modelling of the OTI functionality itself, and a strategy for the performance analysis. First step of the methodology applied by the simulator have been used in the railway between Empoli and Chiusi, which showed that required modelling can be completed with the information available by the railways.

## 4.5 References

- [1] X2Rail-4 Deliverable D6.1: Results of feasibility studies and laboratory tests for candidate technologies selection and adaptation of existing solutions

## 4.6 Acknowledgements

The project X2Rail-4 has received funding from the Shift2Rail Joint Undertaking (JU) under grant agreement No. 881806. The JU receives support from the European Union's Horizon 2020 research and innovation programme and the Shift2Rail JU members other than the Union.

Disclaimer: This dissemination of results reflects only the authors' view and the Shift2Rail Joint Undertaking is not responsible for any use that may be made of the information it contains.



## 4.7 Author



Dr. **Gorka de Miguel** received the M.Sc. degree in Telecommunications Engineering from TECNUN (School of Engineering of San Sebastián), Spain, in 2015 and the Ph.D. degree from the Universidad de Navarra in 2020. He joined the CEIT Research Centre in San Sebastián in 2015, and he is currently a Researcher within the Transport and Sustainable Mobility group. His research activity lies in the field of positioning and software development. He is the co-author of three software registers and the author or co-author of 18 articles in journals and international conferences. He is now actively participating in H2020 European-funded projects in Railway signaling and positioning topics. He is a lecturer assistant in the subject Electronic Fabrication Systems at TECNUN, University of Navarra.

E-Mail: [gdemiguel@ceit.es](mailto:gdemiguel@ceit.es)



**David Izquierdo** received a degree in web and multiplatform applications from Plaiaundi, Spain, in 2020. He joined the CEIT Research Center in San Sebastián in 2020 and is currently a Research Assistant in the Department of Transport. and Sustainable Mobility Group. His research activity is situated in the field of web and mobile software development. Now he actively participates in projects financed with European H2020 funds on railway signaling and positioning issues.

E-mail: [dizquierdoc@ceit.es](mailto:dizquierdoc@ceit.es)



Dr. **Jon Goya** received the M.Sc. degree in telecommunications engineering in 2011 and the Ph.D. degree from the Universidad de Navarra in 2016. He is currently a Lecturer with the TECNUN, Universidad de Navarra, and also a Researcher with the CEIT. His professional research activity lies in the simulation of on-board positioning systems and performance analysis for railway. He has participated in FP7 projects coordinated by CEIT and is now actively participating in H2020 European funded, such as SIA, and Shift2Rail projects in Railway signaling and Positioning topics: X2RAIL-5 and FR8RAIL-IV.

E-Mail: [jgoya@ceit.es](mailto:jgoya@ceit.es)



Dr. **Jaizki Mendizabal** is a researcher at CEIT and a lecturer at TECNUN (University of Navarra). He received his MSc and Ph.D. degrees in Electrical Engineering from TECNUN in 2000 and 2006, respectively. He joined Fraunhofer IIS-A (Germany) from 2000 to 2002 and SANYO Electric Ltd (Japan) from 2005 to 2006 as an RFIC designer. He obtained his Ph.D. in the field of RF design for GNSS systems. Currently, his research interests at CEIT include GNSS, wireless communication, and safety-critical systems for the railway and maritime industry. He has been engaged in the SIL4 design of a safety-critical receiver for an ERTMS BTM for high-speed trains (8M€ project with eight partners), he was the project coordinator of the FP7 EATS project dealing with the introduction of GNSS to onboard ETCS and he is currently working in several Shift2Rail projects apart from being member of the board. He has participated in more than 20 research projects where 6 of them dealt with GNSS for railways. He has directed 5 doctoral theses and more than 20 master and graduate theses. He is author or co-author of 2 patents and 35 scientific and technical publications and is the author of one book and 2 book chapters.

E-Mail: [jmendizabal@ceit.es](mailto:jmendizabal@ceit.es)



# 5 Statistical model checking-based performance analysis of the onboard train integrity

*Insaf Sassi, IRT RAILENIUM, Famars, France*

*Mohamed Ghazel, COSYS-ESTAS, Université Gustave Eiffel, IFSTTAR, Villeneuve d'Ascq, France*

*El-Miloudi El Koursi, COSYS-ESTAS, Université Gustave Eiffel, IFSTTAR, Villeneuve d'Ascq, France*

## 5.1 Introduction

Formalizing the system requirements specifications (SRS) is a complex exercise. In X2Rail-2 project, Model checking was used to systematically check a set of properties pertaining to the on-board train integrity system the specifications of which were proposed in deliverable D4.1 [1]. Indeed, formal validation of functional specifications of Onboard Train Integrity (OTI) function was provided to check consistency, completeness, functional, and safety requirements [2]. In the OTI context, several aspects are taken into consideration such as, for instance, configuration variation, configuration evolution (position, joining, splitting), communication failure, integration of the OTI communication with the on-board ETCS module. In the project X2Rail-4, the subsequent step consists in using the formal models to study the OTI performances. In this context, OTI is considered as an interactive, distributed system that behaves according to the stimulus it receives. Probabilistic aspects such as message loss probability, transmission delays, failure probability are integrated into the analysis. Thus, quantitative properties are specified to check system performances using probabilistic notations and their relevant analysis techniques: probabilistic timed automata [5] in UPPAAL [4]. In fact, statistical model checking (SMC) [6] offers valuable advantages to investigate several properties. It consists in obtaining statistical evidence (with a predefined level of confidence) of the quantitative properties to be checked using sufficient simulation runs based on a given system model. Before starting the quantitative analysis, the models used in X2Rail-2 [2] have been updated while making an abstraction of some details. In fact, unlike in the models provided in X2Rail-2, some functional details such as reset and start inputs, joining and splitting specifications, role updating from Master to slave or vice versa, are not considered to focus only on performance analysis. The new formal models need to be coherent w.r.t the technical implementation and the relevant parameters for performance analysis must be defined.

## 5.2 Approach

The approach used for this work and the different steps of the analysis are as follows:

- Review and update of the Finite state machine (FSM) formal models, used for formal verification of OTI functional specifications, according to the implementation of the different architectures/technologies to target the relevant parameters for performance analysis. Abstractions have been adopted to focus on the relevant part of the specifications related to OTI performance.

- Identify the system performance to be analysed, hence properties to be verified using Probabilistic Computation Tree Logic PCTL (see Figure 5-1), are described as follows:
  - Performance analysis in relation to CR940 (i.e., timer sensitivity analysis and impact on capacity level)
    - When the OTI delivers unknown status, longer safety margins are considered for the track occupancy, therefore impacting on movement authority assigned to the following train and on the availability of the track in general.
    - OTI timers related to non-regular state (i.e., unknown train integrity) imply an increased track occupation.
  - False-positive frequency evaluation which is feasible depending on some parameters: network QoS parameters
  - Detection time of loss of train integrity
- Investigate and identify the various parameters that impact the above-mentioned system performances: timeouts, communication loss rate, etc.
- Perform statistical model checking by considering the following aspects:
  - Non-deterministic choices among multiple enabled transitions modulated by some probabilistic values: weights can be added to give a distribution on discrete transitions.
  - Non-deterministic choice of delays refined by probability distributions
  - Analysis of probabilistic performance properties per mission time
  - Quantitative properties: probability distributions over the reachability time.
  - Perform statistical quantitative analysis using the three possible queries in SMC: probability estimation, sequential hypothesis testing, probability comparison as follows:
    - Estimation of the expected value of certain observable parameters
  - Statistical evaluation can be performed with a large number of runs
- Perform a sensitivity analysis on the different impacting parameters
- Perform a comparative study of the various investigated solutions using simulation and formal verification techniques

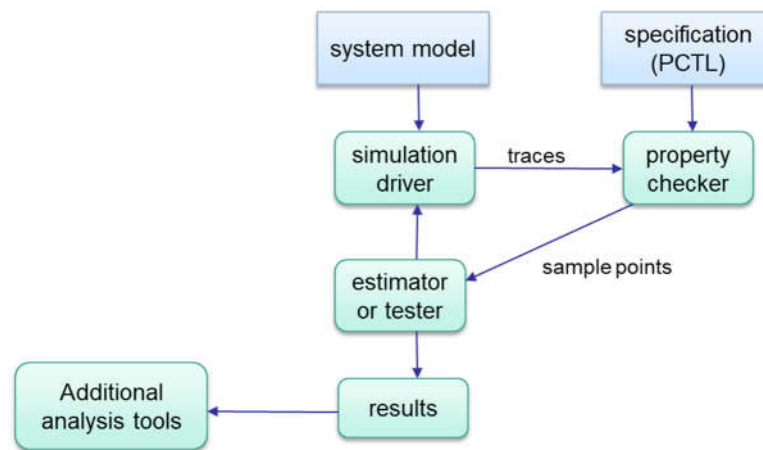

Figure 5-1: Statistical Model Checking Workflow

### 5.3 Simulations scenarios

The following scenarios describe a subset of the simulations that have been performed in X2Rail-4 WP6 in order to collect data about the OTI performance indicators. In this paper, the detection time is chosen to be presented among the indicators. Given the various automaton models described in D6.1 [3], a set of assumptions is considered to focus on the integrity evaluation:

- No failure injections i.e., message loss, nor performance focus in the mastership, identification, pairing, monitoring-initialization phases.
- Only the regular, non-regular and loss monitoring states are investigated in this analysis by taking into consideration the configuration parameters as timers: Latency,  $T_{OTIM\_COMM}$ ,  $T_{OTIM\_L}$ , the rate of the successfully received messages  $N$ . We should recall that these timers are defined as follows regarding every step of the monitoring step as depicted in Figure 5-2:
  - $T_{OTIM\_COMM}$ : duration of the transmission cycle
  - $T_{OTIM\_I}$ : duration of the initialization step
  - $N$ : number of successfully received messages in the initialization phase
  - $T_{OTIM\_L}$ : duration of Non-regular phase (unknown) before switching to loss
- Our analysis focuses on the impact of message loss rate on the OTI performance. The timers are hereby determined by using the sensitivity analysis principle, i.e., One Factor at A time (OFAT), to investigate their impact on the system performances. In all the scenarios, the train integrity monitoring system consists of the OTI-Master (OTI-M) in the active cabin, and the OTI-Slave (OTI-S) in the tail, which communicate with each other via a communication network in order to evaluate the train integrity. The other timers  $T_{STATUS\_TAIL}$  and  $T_{COUPLING\_STATUS}$  will be considered in future work.
- The considered time unit is second, distance in m and velocity in m/s.



- LATENCY is the transmission delay, uniformly varying in ]0..1] of seconds.
- T\_OTIM\_COMM is fixed to 2s.

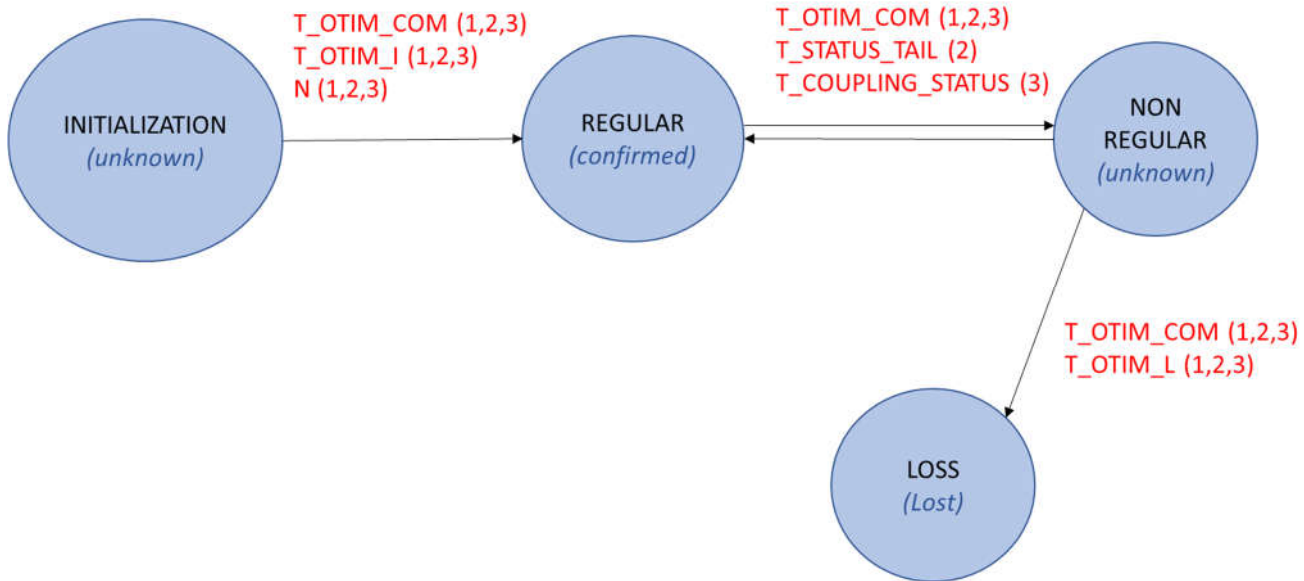

Figure 5-2: Monitoring states

**Simulation scenario 1:** This simulation scenario is devoted to collect data about the detection time of loss of integrity in the case of product class 1 in different network quality of service states according to the message loss rate and the OTI timers. To answer the question on how much time it takes between the occurrence of the physical train separation and its detection by the OTI, the event of physical loss of integrity is triggered at time  $T_{loss}=100s$  (after 100s of operation). In the case of product class 1, where a wired communication medium is used, the loss of integrity results in a total interruption of the communication between the master and the slave.

**Simulation scenario 2:** This scenario permits to collect data about detection time for product class 2 in different network quality of service states, according to the message loss rate and the OTI timers. Note that in this case, the loss of integrity criteria is based on the evaluation of the velocity gap  $\Delta V$  and/or travelled distance gap  $\Delta X$  between the OTI master, head of the train, and the OTI slave in tail installed in the last wagon. The considered unit for the distance measuring is meter (m) and the one for the velocity is meter per second m/s.

## 5.4 Analysis approach description

The objective of this analysis is to provide some means in order to help choose the OTI configuration parameters, mainly the timers values, using OFAT sensitivity method, so as to optimize a number of OTI performance criteria. Hence, to choose the model parameters impacting the system performance, we proceed as follows:

- Fixing the value of the message loss rate

- Varying **T\_OTIM\_L** (duration of Non-regular phase (unknown) before switching to loss) while reducing the probability of false alarm (due to communication errors) to 0 for 10 hours of operation using simulation scenario 1.
- Measuring the unknown rate for each value of T\_OTIM\_L in a mission of 10h of operation recorded before delivering a loss of integrity because of a false alarm using simulation scenario 1.
- Investigating the detection time for each value of T\_OTIM\_L corresponding to a message loss rate using simulation scenario 1 for product class 1 and simulation scenario 2 for product class 2.

In order to collect the data needed for the analysis, SMC is used by checking quantitative properties based on the model simulation. The SMC properties that have been considered in this analysis are listed in Table 5-1.

Table 5-1 List of SMC properties

OTI Performance Indicator	SMC Property	Output
<b>Detection time</b>	<p>Reachability property of Lost state: <math>Pr[\leq 300](\langle \rangle integrity\_status\_oti.Lost)</math></p> <p>Where time_bound=300s (&gt;T_loss=100s) represents the time bound and duration of the simulation.</p>	<p>The output consists of a Probability distribution of reachability time of the state <i>Lost</i> in the automaton integrity_status_OTI <b>after the loss of integrity event occurs at T_loss=100s</b>. The result provides the possible values of the reachability time with their associated probability and the average time as depicted in <b>Fehler! Verweisquelle konnte nicht gefunden werden..</b> The maximum and the minimum of detection time, its most probable value as well as its average can be derived by subtracting T_loss=100s from the obtained reachability time. In instance, from <b>Fehler! Verweisquelle konnte nicht gefunden werden.</b> average detection time=average reachability time (113,5s)-T_loss(100s)=13,5s</p>

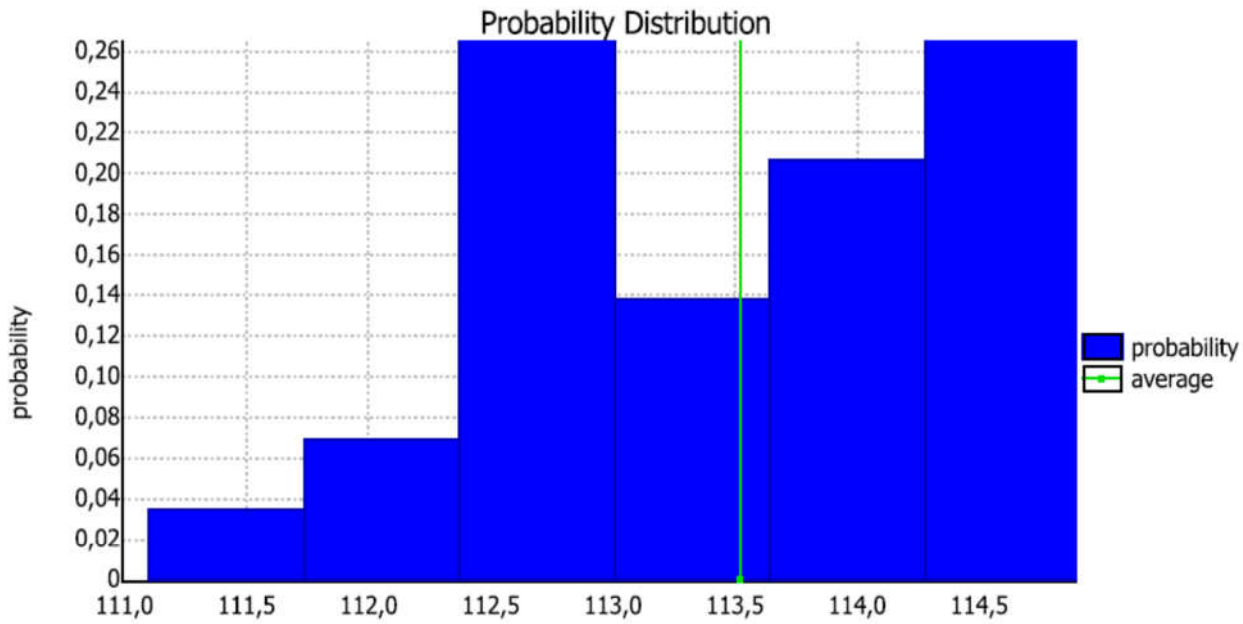

-1

Parameters:  $\alpha=0.05$ ,  $\varepsilon=0.05$ , bucket width=0.63535, bucket count=6  
 Runs: 29 in total, 29 (100%) displayed, 0 (0%) remaining  
 Span of displayed sample: [111.1, 114.9]  
 Mean from displayed sample: 113.5  $\pm$  0.391 (95% CI)

Figure 5-3: Probability distribution of reachability time of Lost state after  $T_{LOSS}=100s$ :  
 $T_{OTIM\_L}=12s$ , Message loss rate =20% (product class 1)

## 5.5 Analysis results

In the case of product class 1 and according to its integrity evaluation criteria, timer  $T_{OTIM\_L}$  represents the period of time used to filter the false alarm before reporting a loss of integrity with a direct impact on the detection time, which is the time elapsed from the occurrence of the train separation event to the time when loss of integrity is reported. Figure 5-4 shows well that in the case of product class 1, the detection time (orange curve) tends to evolve with  $T_{OTIM\_L}$ . The analysis consists in improving the OTI performance by reducing the probability of false alarm, due to message loss, to an interval of values in **[0; 0,004]** with a confidence interval of 99%. The possible values of  $T_{OTIM\_L}$  that shall fit the network quality of service in terms of message loss rate and reduce the false alarm rate due to communication errors are depicted in Figure 5-4. We can also notice that the detection time of loss of integrity is evolving exponentially with  $T_{OTIM\_L}$  and with the rate of message loss as depicted in Figure 5-4. In addition to the average detection time, it is worthy to investigate the maximum values of detection time, as the worst-case delay, in order to define the safe limit (or zone) for the running train. Therefore, according to the chosen value of  $T_{OTIM\_L}$ , there is a risk of having a time of detection that reaches the authorized maximum value.

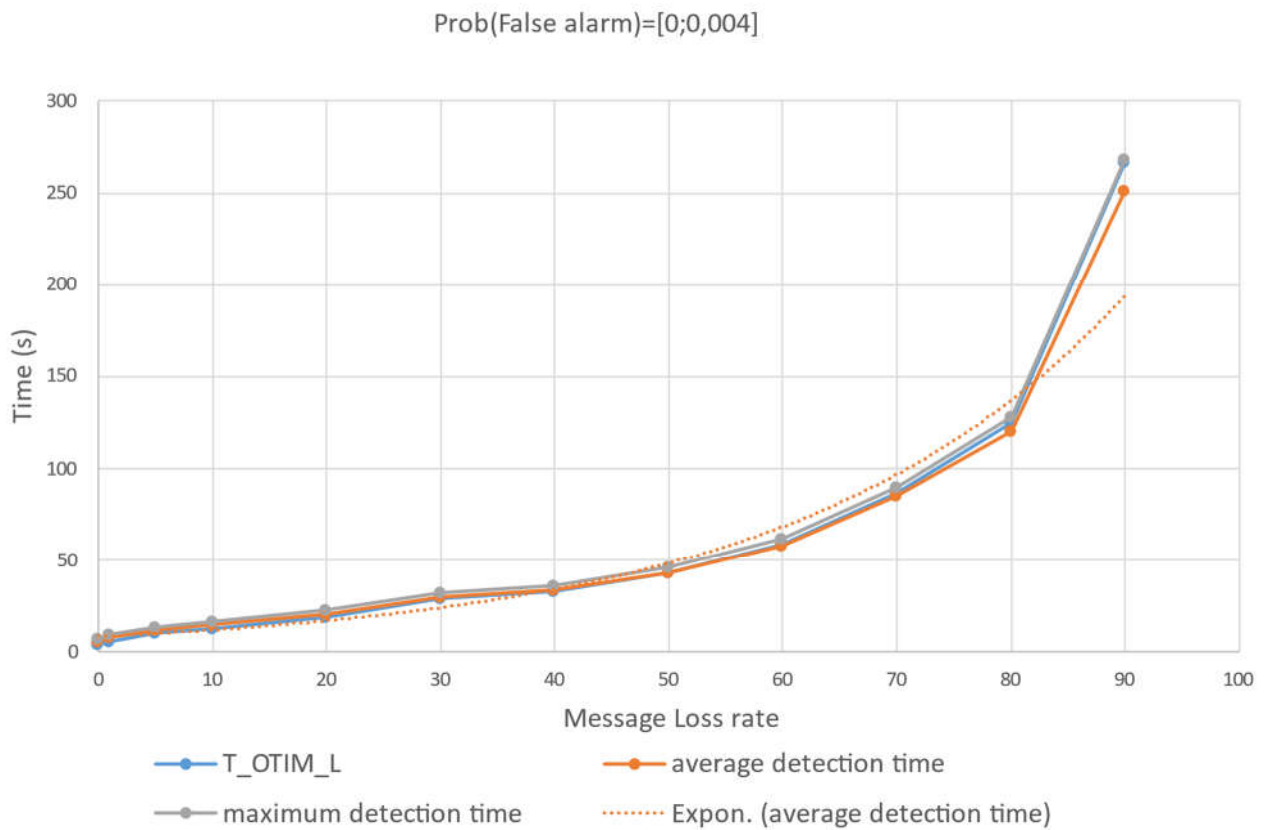

Figure 5-4: Average and maximum Detection time evolution as a function of message loss rate, for product class 1

Regarding the detection time in the case of product class 2, the train integrity criterion is based on evaluating the velocity gap  $\Delta V$  between OTI Master and OTI Slave. The threshold of velocity comparison to detect the loss of integrity is chosen to be 3m/s where  $\Delta V > 3\text{m/s}$ . Once, the OTI-M detects this velocity variation and the loss of integrity, the train shall start braking until it comes to standstill. The detection time for product class 2 has been recorded as shown in Figure 5-5 by varying the message loss rate.  $T_{OTIM\_L}$  values have been chosen to ensure availability by avoiding the false alarm (Prob (false alarm)) in [0;0,004] due to communication errors. Note that the detection time depends on the chosen threshold of  $\Delta V$ . In product class 2, a wireless network is used to ensure the communication between the master and the slave located in the train tail. Considering another criterion, as the  $\Delta V$  to evaluate the train integrity, makes it possible to detect the loss of integrity before completely losing the communication between the master and the slave. Therefore, the average detection time of product class 2 is not sensitive to  $T_{OTIM\_L}$  as shown in Figure 5-5, but rather to the message loss rate assuming that the transmission latency does not exceed 1s and  $T_{OTIM\_COMM}$  is fixed to 2s. However, by studying the maximum detection time as the worst-case delay, it has been shown that this delay evolves with  $T_{OTIM\_L}$  as depicted in Figure 5-5. Note that having a delay to detect the loss of integrity equal to the maximum detection time is possible with a certain probability

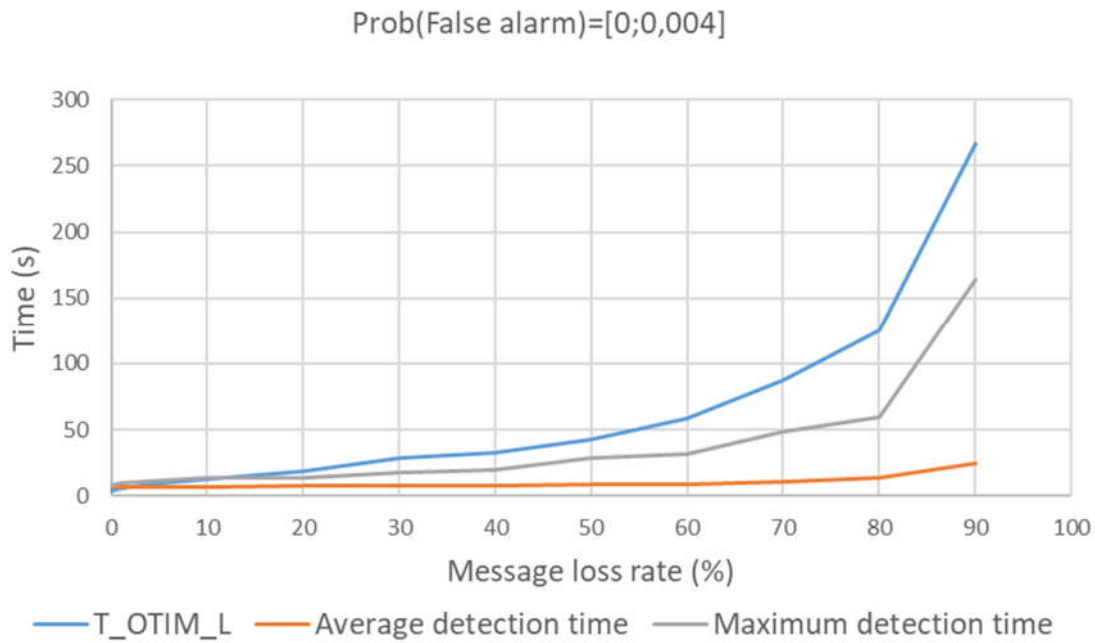

Figure 5-5: Average and maximum Detection time evolution as a function of message loss rate, for product class 2

## 5.6 Conclusion

An analysis of the OTI performance indicators has revealed many important aspects of the OTI implementation. Sensitivity analysis has allowed us to determine which impacting parameters and factors should be taken into consideration to understand the evolution of some indicators such as the probability of false alarm, number of reported unknown integrity status and detection time of loss of integrity. In fact, this study highlights the impact of the quality of service of the communication network, in terms of loss of message rate, on the OTI performance. It provides a policy to choose the system configuration parameters, mainly, the OTI timers ensuring an acceptable level of availability and safety. One of the considered timers is T\_OTIM\_L which represents the period of time where the master waits for slave status information before reporting a loss of integrity status. This analysis has shown the impact of T\_OTIM\_L and message loss rate on the performance indicators for product classes 1 and 2. This study will be pursued in X2Rail-4 WP7 to analyze the impact of other configuration parameters. Further results will be published in deliverable D7.1 [7].

## 5.7 References

- [1] X2Rail-2 D4.1 Train Integrity Concept and Functional Requirement Specification V5.0, 2020.
- [2] SASSI, Insaf, GHAZEL, Mohamed, et EL-KOURSI, El-Miloudi. Formal modeling of a new On-board Train integrity System ETCS Compliant. In: ESREL 2021, 31st European Safety and Reliability Conference. 2021. p. 9p.
- [3] X2Rail-4 D6.1 Results of feasibility studies and laboratory tests for candidate technologies selection and adaptation of existing solutions, 2020.
- [4] Gerd Behrmann, Alexandre David, and Kim G. Larsen, A Tutorial on Uppaal 4.0, Update of November 28, 2006

- [5] Rajeev Alur and David L. Dill, A Theory of Timed Automata, Theoretical Computer Science No. 126, pp. 183-235, 1994.
- [6] Alexandre David, Kim G. Larsen, Axel Legay, Marius Mikucionis, and Danny Bogsted Poulsen, Uppaal SMC Tutorial, January 2018.
- [7] X2Rail-4 D7.1 Demonstration and assessment, 2022.

## 5.8 Acknowledgements

The project X2Rail-4 has received funding from the Shift2Rail Joint Undertaking (JU) under grant agreement No. 881806. The JU receives support from the European Union's Horizon 2020 research and innovation programme and the Shift2Rail JU members other than the Union.

Disclaimer: This dissemination of results reflects only the authors' view and the Shift2Rail Joint Undertaking is not responsible for any use that may be made of the information it contains.



## 5.9 Authors



Dr. **Insaf Sassi** has received the engineering degree from the National School of Computer Sciences (ENSI), Tunisia, in 2014; the master's degree in control systems from Ecole Centrale Lille, France, in 2014; and the Ph.D. degree in control systems from University of Grenoble Alpes in 2017. She joined Railenium as post-doctoral fellow in 2018 and then as safety research engineer to work on RAMS analysis. Her research deals with dependability and safety analysis of railways systems. She contributed in X2Rail-2 WPail-4, X2Rail-2 WP3, and X2Rail-4 WP6 and 7 projects.

E-Mail: [insaf.sassi@railenium.eu](mailto:insaf.sassi@railenium.eu)



Dr. **Mohamed Ghazel** is a Research director with the COSYS/ESTAS team at Université Gustave Eiffel (ex IFSTTAR). He received the Master's and Ph.D. degrees in automatic control and industrial computer sciences from École Centrale de Lille in 2002 and 2005, respectively; and the Habilitation à Diriger des Recherches from University Lille Nord de France in 2014. He specialises in safety and interoperability analysis of transportation systems using discrete models. He is member of the IFAC TC 7.4 on Transportation Systems, he has been involved in several national and European research projects and acts as expert for the European Commission in the framework of innovation programs.

E-Mail: [mohamed.ghazel@univ-eiffel.fr](mailto:mohamed.ghazel@univ-eiffel.fr)



Dr. **El-Miloudi El-Koursi** is a Research Director at Université Gustave Eiffel (ex IFSTTAR). He has 30 years experiences in performing assessment and certification of safety related rail and associated systems. He obtained in 1985 his Ph.D in Automatic control and industrial computer sciences at University of Lille. In recent years, he has been involved in various European projects. He was the leader of European FP5, SAMNET “Safety Management and interoperability thematic network” thematic network. He is the vice chairman of EURNEX.

E-Mail: [el-miloudi.el-koursi@univ-eiffel.fr](mailto:el-miloudi.el-koursi@univ-eiffel.fr)

# 6 Cost Benefit Analysis for OTI – Methodology and Results

*Alessa Isberner, Benedikt Scheier, Florian Brinkmann; DLR, Braunschweig, Germany*

## 6.1 Introduction and Aim

A study performed on Network Rail and Deutsche Bahn real scenarios for regional and high capacity lines has been conducted about the life cycle costs for on-board train integrity control (OTI) being developed within X2Rail-4 project of Shift2Rail. The expected costs were compared to the saving potential through the elimination of infrastructure components. The following advantages of shifting the train integrity control from the track to the train are expected: On the one hand, the energy supply, maintenance, servicing and reinvestment of trackside elements such as axle counters and track circuits are significant cost factors that represent an economic disadvantage, especially on lines with a low density of trains and short block distances. It can therefore be assumed that a cost saving can be realised here through OTI. On the other hand, the saved costs of the field elements must be compared against the costs for the additional train equipment. Further calculations have been performed on the cost difference of retrofitting with SIL-2 or SIL-4 devices.

Furthermore, a simulation model has been used to investigate the effects on capacity when operating with moving block for which OTI is an enabler. For the analysis of capacity gains through moving block, two high-density lines with mixed traffic and one low density line have been chosen. Of the two high density lines one is located between Offenburg and Freiburg in Germany, the other one is a section of the West Coast Main Line (WCML) in the United Kingdom (UK). The low-density line is located in Wales (UK). In addition to the line capacity analysis, the effects of applying moving block in nodes and stations has been investigated. Due to the different approaches of reserving track sections, differences in the occupation of tracks in the node and therefore differences in the headway are expected. Here, an additional improvement can be expected for lines with high density of trains and nodes that are at their capacity limits [1,2].

## 6.2 Methodology and Results

### 6.2.1 Life Cycle Cost Analysis

A Life Cycle Cost (LCC) analysis based on the Net Present Value (NPV) approach has been performed in order to evaluate the changes in the cost structure. The LCC approach is useful for assessing technological implementations with a long service life.

$$NPV = \sum_{t=0}^T \frac{B_t - C_t}{(1+i)^t}$$

Equation 6-1: Calculation of the Net Present Value



where  $t$  = year under consideration,  $B_t$  = benefits in year  $t$ ,  $C_t$  = costs in year  $t$ ,  $T$  = lifespan of the project (in this case 30 years),  $i$  = discount rate in year  $t$  (in this case 3%) [3].

The cost calculation and determination of the number of trains which are relevant for each scenario has been described in detail at the SmartRaCon Conference 2020 [4].

Results of the analysis show that on the Cambrian line in Wales, costs can be saved even if 50% of the trackside elements remain installed (see Figure 6-1). Reasons are that no freight trains are running and only one passenger train service every hour. This means that only few trains have to be fitted with the new OTI technology. At the same time, a lot of trackside infrastructure is on the line, making it expensive. On the other two lines, the number of trains that need to be equipped with the new technology is much higher. This has the result that the cost ratio is only positive when most of the trackside elements can be removed (10% remain on WCML and 25% Offenburg scenario). A limitation of these results has been the sole focus on regional and freight traffic (not including high speed trains and potential costs for retrofitting), thus the real numbers are assumed to be lower [5].

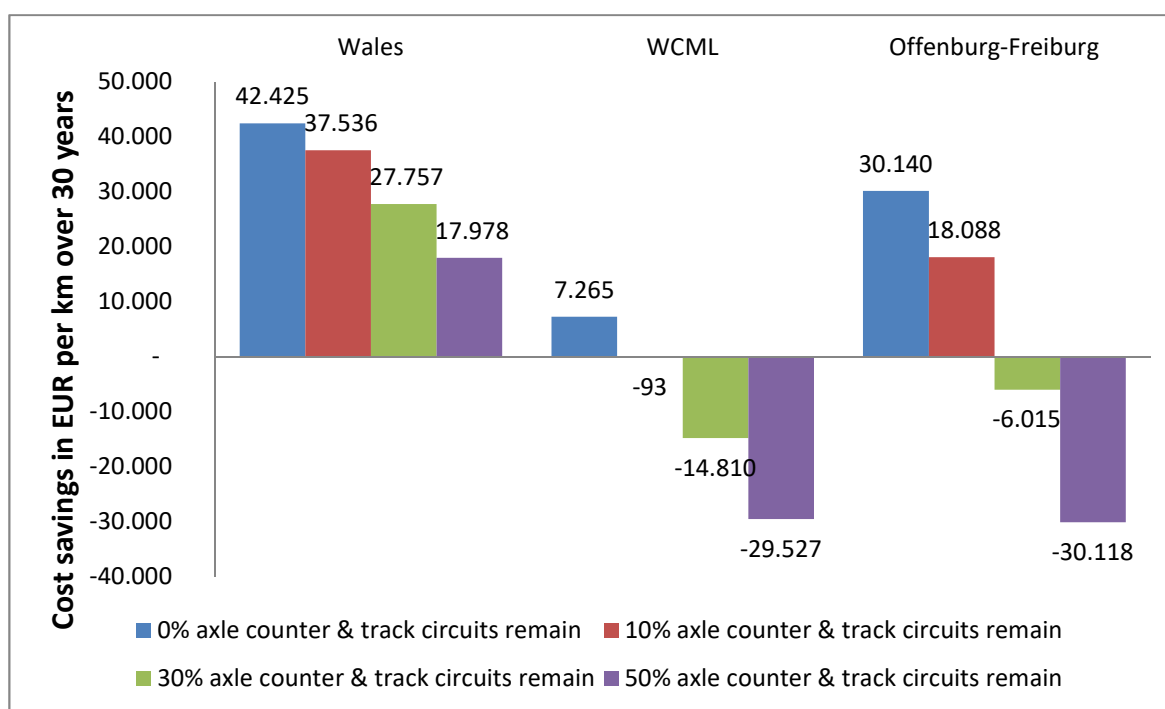

Figure 6-1: Cost savings per km for different amount of trackside infrastructure

Further calculations have been performed on the cost difference of retrofitting with SIL-2 or SIL-4 devices. As cost estimations for a SIL-2 device have only been available from expert estimation, the overall costs for the SIL-2 OTI device have been assumed to lie in a range of 50%-70% of the costs of a SIL-4 product. The results of Figure 6-2 show that the main lever are freight trains as the cost to equip freight trains with OTI technology is a lot more cost intensive due to every freight vehicle needing to be equipped, and higher costs for wireless solutions (when compared to fixed-formation passenger trains) [1].

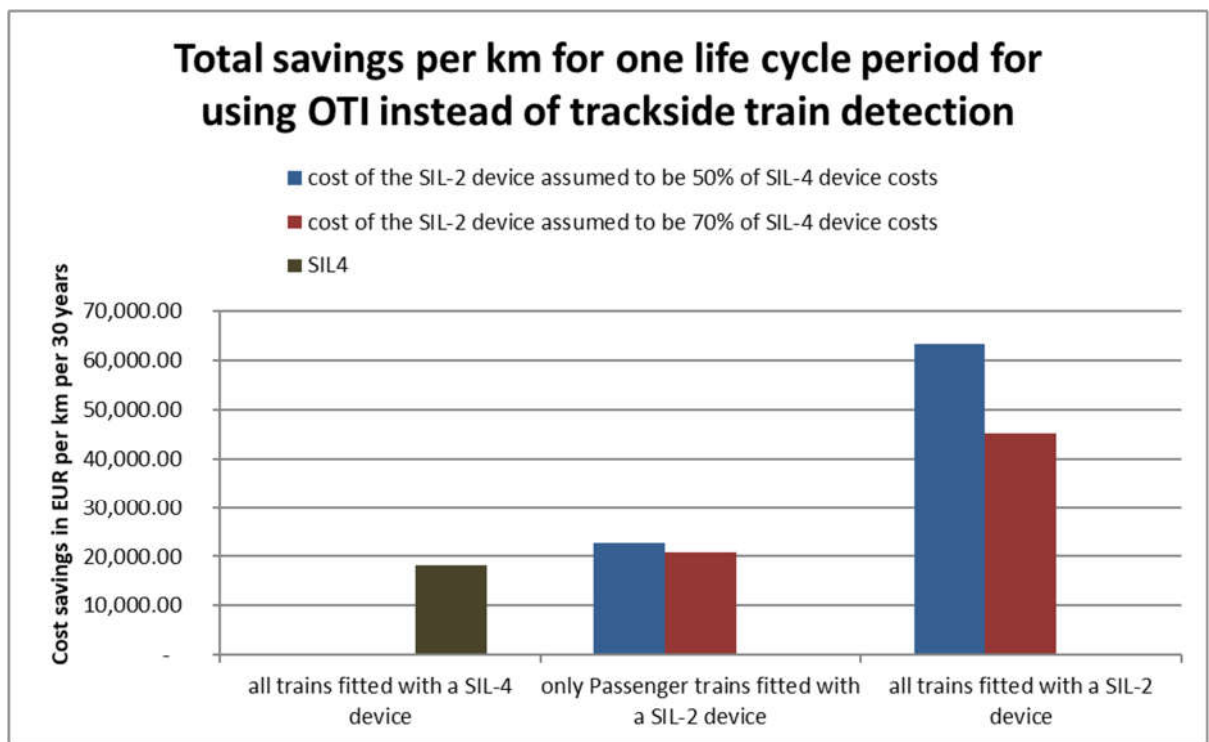

Figure 6-2: Cost savings in the Offenburg scenario with a SIL-2 device

### 6.2.2 Capacity Analysis

For the investigation on the effects of applying moving block in nodes and stations in the specific scenarios, a microscopic simulation has been applied, because detailed models of trains as well as the infrastructure (e.g. switch positions) are needed. The simulation tool OpenTrack of the Swiss company OpenTrack Railway Technology Ltd was used for the microscopic simulation as it provides the possibility to apply moving block operation [6]. The critical areas in the analysed corridor are in front of Freiburg and Offenburg where additional regional train lines merge onto the main line. In Offenburg an additional factor that limits capacity is the fact that some of the freight trains need to cross through the oncoming traffic as they need to merge into the marshalling yard. Even though the block distance in these areas is already very short with 1-1.5 km, the capacity consumption is lowered from around 80% to 55% (evaluation of capacity consumption according to UIC Code 406) [7], meaning an improvement to the recommended value for maintaining satisfactory operating quality. Figure 6-3 shows two train diagrams of a section of the analysed corridor with fixed blocks (left) and moving block approach (right). On the x-axis the distance of the section is shown and on the y-axis the time. The grey shaded areas visualise the time that a track section is blocked by one train thus showing bigger stairs shaped areas when the legacy system uses fixed blocks.

## Niederschopfheim - Offenburg - Gengenbach

## Niederschopfheim - Offenburg - Gengenbach

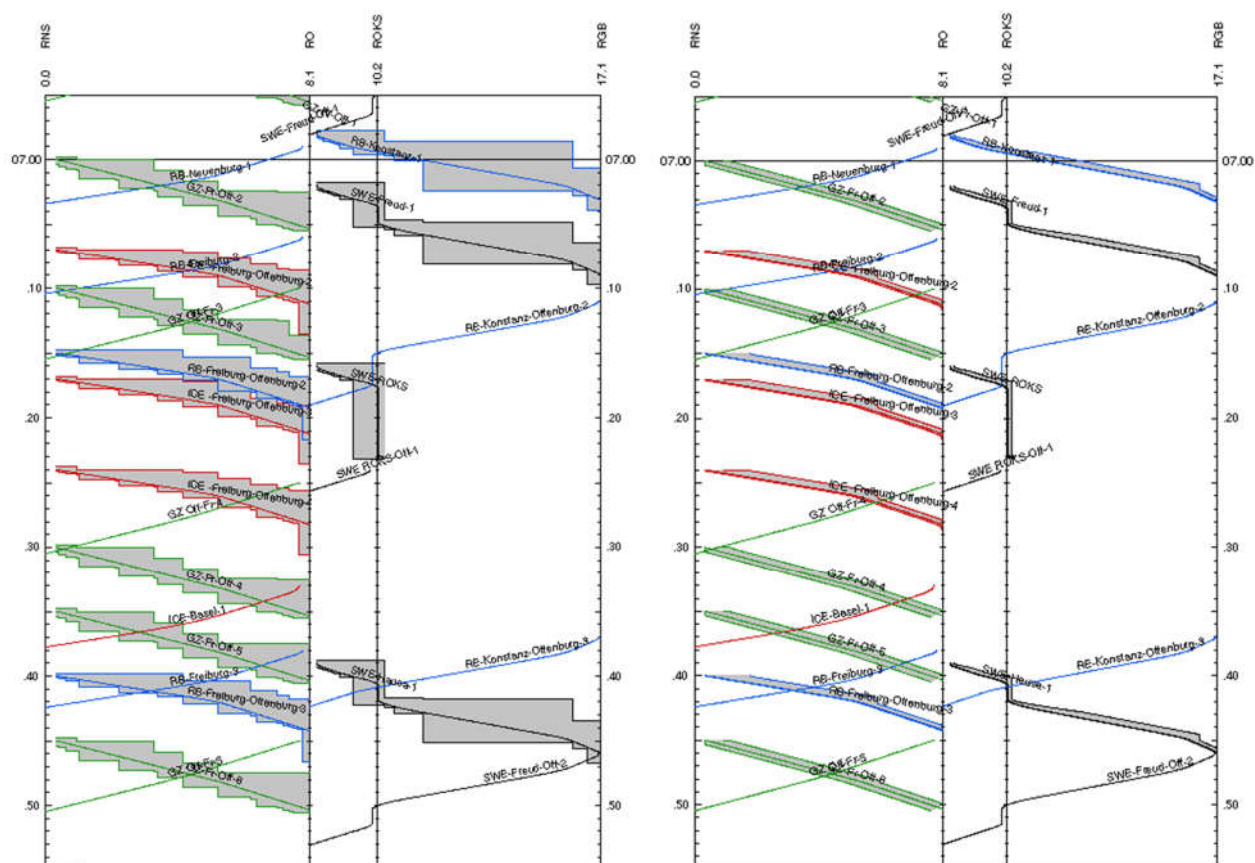

Figure 6-3: Train diagram between Freiburg and Offenburg with current fixed block (left) moving block approach (right)

Even though, the gain in capacity has not been monetarised as it can only be partially attributed to the OTI technology it is an important benefit. It shows that there are additional factors besides the direct costs that are important to consider when making an economic comparison between on-board and trackside infrastructure functionalities [2].

With moving block operation, an increase in capacity can also be achieved in nodes. The occupation rate of the critical switches and crossings in the Moving Block scenario in Offenburg station (see Figure 6-4), could be reduced to about 50% - 33% compared to the fixed block scenario (see Table 6-1) [2]. The location of the switches and crossings analysed are visualised in Figure 6-4 and the results documented in Table 6-1.

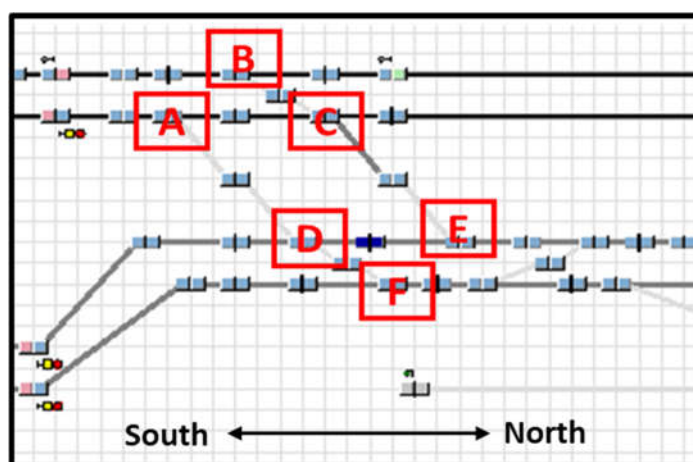

Figure 6-4: Node-edge model of Offenburg station with switches and crossings (A-F)

Table 6-1: Occupation rate of relevant switches and crossings in Offenburg station (A-F)

Switch/ crossing	Fixed occupation rate [%]	block Moving block occupation rate [%]	Occupation level of switch/crossing
<b>A</b>	32.2	9.6	Bottleneck 1: highly occupied switch; all trains coming from the South need to cross here
<b>B</b>	19.2	8.1	Medium occupied switch; all trains coming from the North cross here
<b>C</b>	28.2	9.5	Bottleneck 2: same level crossing of freight traffic coming from North with passenger traffic coming from south
<b>D</b>	24.4	8.8	Medium high occupied switch; freight traffic coming from South crossing traffic coming from side line
<b>E</b>	19.2	9.3	Medium occupied switch; freight traffic coming from the South is crossing traffic coming from side line; interesting fact, moving block effect is not as high as for other points
<b>F</b>	23.7	7.6	Medium high occupied switch, freight traffic coming from the South crossing passenger traffic coming from the side line

## 6.3 Conclusion

Train integrity monitoring with trackside equipment was compared to the onboard train integrity with on-board unit. For low density lines, the results show that train integrity monitoring with on-board units is more economical due to the limited amount of trains that need to be equipped and the high costs for the infrastructure elements.

For high density mixed lines, the break-even point between both technologies under the stated assumptions was between a level of remaining trackside elements of 10-25%.

The track circuits and axle counters on the infrastructure however do not solely monitor train integrity but also provide the location of the train. When trackside elements are removed it has to be considered that the functionality of safe train positioning and the determination of the train length are safety relevant information that needs to be provided. For this reason, the additional functionality of train length determination has been added to the project, however this had been done at an advanced stage of the project after the analysis which is described here had been performed.

From the capacity analysis it can be concluded that with moving block operation, an increase in line capacity as well as the capacity in the analysed station is possible. Whether this is only the case for this specific station or whether it can be transferred to other stations has not yet been investigated.

## 6.4 References

- [1] D4.5 Cost benefit analysis - X2Rail-2 – February 2020
- [2] D6.2 Cost benefit analysis – X2Rail-4 – December 2020
- [3] J. Nellthorp, “The principles behind transport appraisal,” in the Routledge Handbook of Transport Economics, 2017, pp. 176-208.
- [4] Eckert, Alessa (2020) CBA – Assessment methodology for shifting railway technology from the infrastructure onto the train. In: Proceedings of the 2nd SmartRaCon Scientific Seminar, 37, Seiten 73-79. 2nd SmartRaCon Scientific Seminar, 24. Nov. 2020, San Sebastian
- [5] Eckert, Alessa und Brinkmann, Florian und Scheier, Benedikt (2020) Kostenvergleich einer innovativen Zugvollständigkeitskontrolle / A cost comparison of innovative train integrity control. SIGNAL + DRAHT, 12/20 (112), Seiten 52-58.
- [6] D. Huerlimann und A. Nash, „Open Track-Simulation of Railway Networks Version 1.9,“ [Online]. Available: [http://www.opentrack.ch/opentrack/opentrack\\_e/opentrack\\_e.html](http://www.opentrack.ch/opentrack/opentrack_e/opentrack_e.html).
- [7] UIC, „UIC Leaflet 406 - IV Operating,“ Paris, 2013

## 6.5 Acknowledgements

The project X2Rail-4 has received funding from the Shift2Rail Joint Undertaking (JU) under grant agreement No. 881806. The JU receives support from the European Union’s Horizon 2020 research and innovation programme and the Shift2Rail JU members other than the Union.

Disclaimer: This dissemination of results reflects only the authors’ view and the Shift2Rail Joint Undertaking is not responsible for any use that may be made of the information it contains.



## 6.6 Authors



**Alessa Isberner** is scientific staff at the Institute of Transportation Systems of the German Aerospace Center since 2018 after graduating from the Institute of Transport Studies (ITS) at the University of Leeds. She works in the X2Rail-4 project on the Cost-Benefit Analysis of the On-board Train Integrity technology.

E-Mail: [Alessa.isberner@dlr.de](mailto:Alessa.isberner@dlr.de)



**Benedikt Scheier** is scientific staff at the Institute of Transportation Systems of the German Aerospace Center since 2007. His focus is on the design and impact assessment of new transportation technologies and innovative mobility concepts.

E-Mail: [Benedikt.Scheier@dlr.de](mailto:Benedikt.Scheier@dlr.de)



**Florian Brinkmann** is team leader at the Institute of Transportation Systems of the German Aerospace Center. The focus of his research group is the design and impact assessment of new transportation technologies and innovative mobility concepts.

E-Mail: [Florian.Brinkmann@dlr.de](mailto:Florian.Brinkmann@dlr.de)



## 7 An iterative algorithm for the coordinated train rerouting and rescheduling problem

*Xiajie Yi, IRT RAILENIUM, Famars, France*

*Grégory Marlière, COSYS-ESTAS, Université Gustave Eiffel, Villeneuve d'Ascq, France*

*Paola Pellegrini, COSYS-ESTAS, Université Gustave Eiffel, Villeneuve d'Ascq, France*

*Joaquin Rodriguez, COSYS-ESTAS, Université Gustave Eiffel, Villeneuve d'Ascq, France*

*Raffaele Pesenti, Dept. of Management, Università Ca' Foscari Venezia, Venice, Italy*

### 7.1 Introduction

Due to perturbations (i.e., an unexpected, degraded operation), a common problem faced by traffic controllers is that timetables for trains are not necessarily operated as they were planned. This paper deals with a collaborative train rerouting and rescheduling problem to minimize the impact of such a perturbation, i.e., to minimize delay propagation. We consider the coordination of traffic management across different regional railway control centers, and divide the real-time railway traffic management into two decision levels. At the lower level, dispatchers manage train schedules and routes in their own control areas. At the higher level, a coordinator ensures the compatibility of dispatchers' decisions over two or more areas. In this paper, we propose an iterative algorithm to optimize the problem.

The problem we consider is known in the literature as real-time Railway Traffic Management Problem (rtRTMP) [1]. Typically, the railway network is divided into non-overlapping control areas. Each control center coordinates one or several control areas. Several approaches have been proposed to deal with the problem [2]. Nevertheless, only few papers focus on the coordination of traffic management across different control areas. Sometimes, it would be problematic if dispatchers from two connected control areas gave contrary priorities to the same pair of trains. From this point of view, we consider integrated operations of various control areas.

### 7.2 Definitions

In this paper, two control areas are called adjacent if a train can move from one to the other without crossing any other control area. Two adjacent control areas can either be separated or bordering: they are separated if trains can move from one to the other one under the control of a coordinator via a line, whereas they are bordering if trains can only move from one to the other one directly. The space connecting adjacent control areas is named coordinator space. It is composed of border sections: points between bordering control areas and lines that join separated ones. Remark that several border sections can connect two adjacent control areas. We illustrate an example of a coordinator space with two trains and four stations in Figure 7-1, and each train traverses three stations.



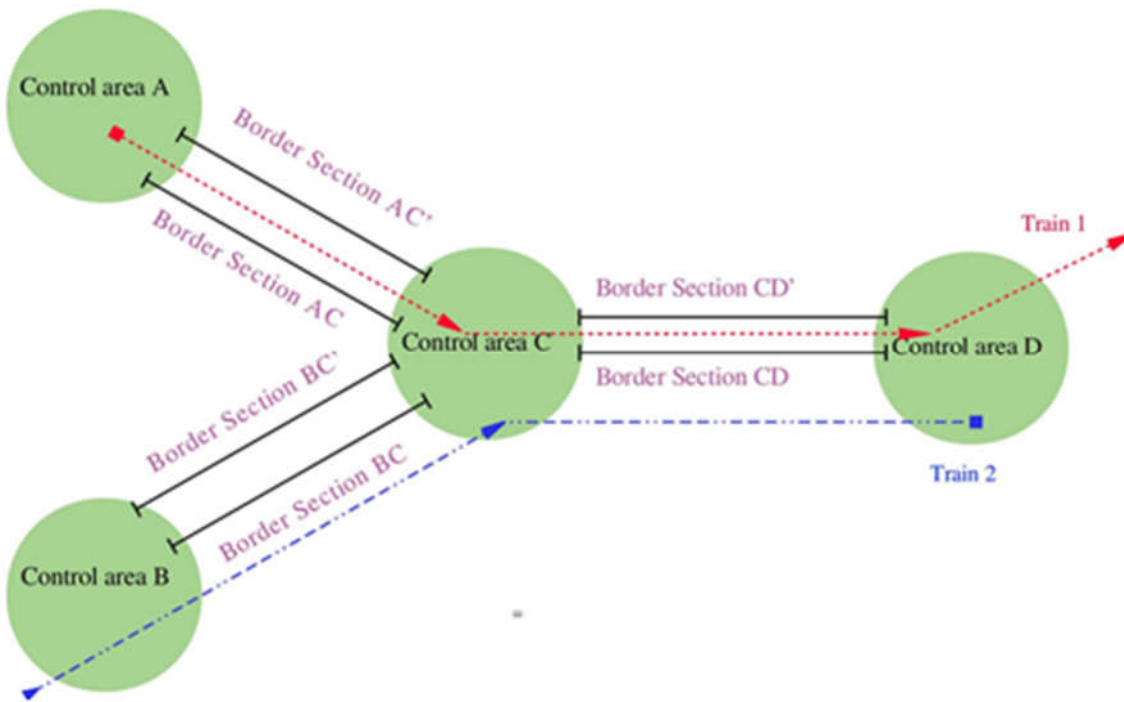

Figure 7-1: An example coordinator space with two trains and three stations

We organize the rtRTMP into two levels, and we refer to the problems tackled at the higher and lower levels as coordination and dispatching problems, respectively.

The coordinator problem consists in choosing precedences between trains using the same border sections, and possibly the specific border sections used by each train if alternative options exist. In this study, we assume that the sequence of control areas traversed by a train cannot be modifiable, which may be relaxed in the future. The dispatching problem consists in finding a traffic management strategy which is compliant with the choices of the coordinator. When trains travel from a control area to an adjacent separated one, some flexibility exists on the running time along the line: the exit time decided for the former does not directly imply the entrance time for the latter, or vice versa. When the travel is from a control area to an adjacent bordering one, instead, no flexibility exists and the exit time from the first one directly implies the entrance time in the second: the latter must precede the former of a time dictated by the interlocking system.

The dispatcher is in charge of choosing precedences between trains sharing track portions (track-circuits, block sections, track sections, ... according to the model adopted for the control area dealt with), train timings and train routes within their control area, provided their consistency with the entrance and exit precedences and locations chosen by the coordinator. We assume that a train starts and ends its journey in a control area among the ones considered. Besides, border sections connect pairs of control areas: given a border section, a train traversing it necessarily uses its origin and its destination control areas. Instead, pairs of control areas can be connected by several border sections (e.g., multiple tracks).

## 7.3 Methodology

We propose an iterative algorithm to optimize the collaborative real-time railway management problem. At each iteration, the coordinator solves the problem of choosing precedences ( $y^-$ ) and locations ( $x^-$ ) of trains passing from a control area to an adjacent one with the objective of minimizing delay estimates. We do so by solving an integer linear programming formulation based on time-indexed binary variables. Precedences and location choices are passed to dispatchers, who solve the real-time traffic management problem in each control area to comply with them, by choosing internal precedences ( $y$ ) and routes ( $x$ ).

Given the decisions from the higher level, the dispatcher sends feedback to the coordinator if a feasible solution does not exist in that control area. As a result, some additional constraints in the form of cuts will be added to the formulation. In this case, a new iteration starts. If feasible solutions exist for all control areas, the set of all routes and precedences there defined constitute a detailed and complete traffic management strategy for the whole network.

However, the internally computed timings may not be coherent when complete train paths are considered. To coherently assess these timings and hence delays, we solve an overall LP in which precedences and routes are inputs. Here, track capacity constraints translate in having non-overlapping train utilization of common portions. We then pass the optimal solution and the shadow prices of the overall LP to the coordinator so that as to either modify delay estimates or define cuts that exclude the current solution in the next iteration. In addition to the timing and objective function assessment, the solution of the overall LP supplies the shadow prices of capacity constraints. We use these shadow prices to define cuts which will be added to the coordinator problem in the next iteration, to try to progressively improve solution quality. The whole iterative algorithm is stopped by the total computational time limit, i.e., when reaching this time limit, the calculating process will be stopped.

## 7.4 Implementation of the iterative algorithm

In this section, we describe the algorithmic choices we made in our implementation of the iterative algorithm mentioned above. The proposed iterative algorithm is depicted in Figure 7-2.

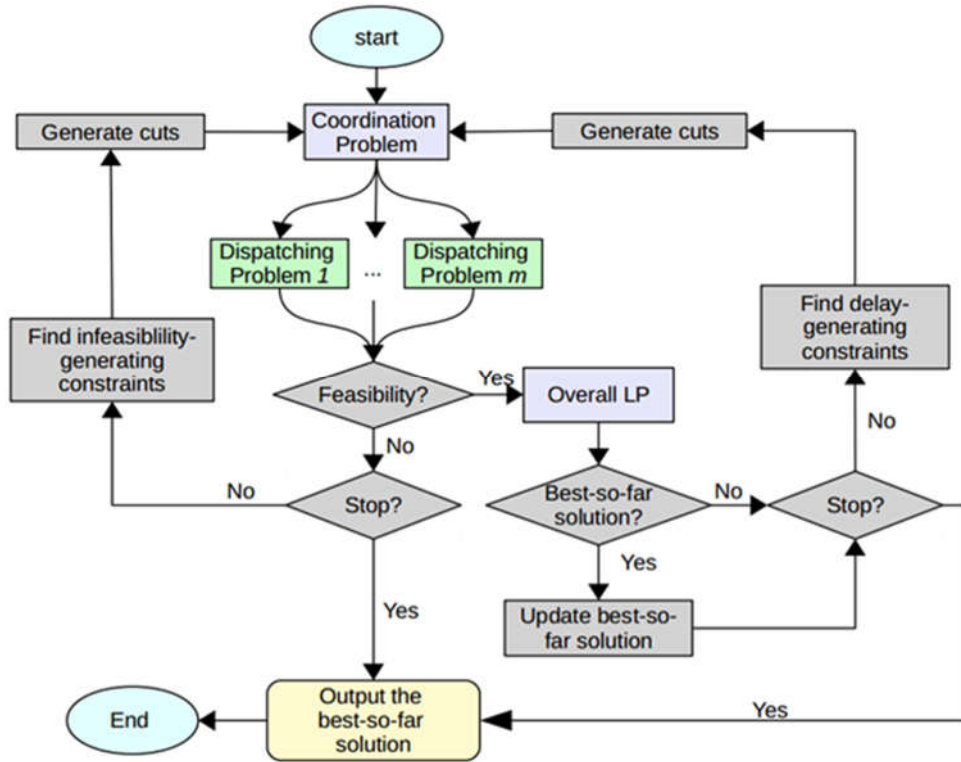

Figure 7-2: Flowchart of the iterative algorithm

For the coordinator problem, we propose a time-index formulation to model the coordination problem. The planning horizon is divided into  $H$  intervals, each with the same length. The value of  $H$  has to be large enough to cover the time range considered in the problem. In this model, both control areas and border sections will be named resources. The use of a resource will be named movement: a train journey is a sequence of movements, taking place in resources that can be either border sections or control areas. Recall that the use of control areas is not an option: the control area traversed by a train is per-defined and not modifiable. Instead, possible alternative border sections may exist.

Hence, we will consider a set of movements for a train, of predefined cardinality. For some of these movements, alternative resources may be available, in particular if the resource is a border section. The objective function of the coordinator problem is to minimize the sum of deviation from the expected entering times over the control areas.

The coordinator decides the locations and precedences for every train, after which decisions in each area are passed to corresponding dispatchers. Each dispatcher only consider the trains and the resources in his own control area. Given those decisions, a dispatcher has to check if it is feasible in his own control area. If it is infeasible, dispatchers(s) will send feedback to the coordinator. The coordinator thereby will further adapt the feedback(s) and reconsider his decisions. In our implementation, we use RECIFE-MILP for solving the dispatcher problem, which has been studied before (see e.g. [1],[3],[4]). If all dispatchers confirm the feasibility of the passed decisions, we calculate the overall LP.

Once we have an overall LP solution, we need to check if the new solution is improved or still acceptable. If yes, we first update the solution set and further detect a cut that potentially generate delays. This cut will be added as a constraint back to the coordinator. If not, the last

added cut that made the new solution unacceptable is abandoned. We go back to the previous overall LP solution and try to find another delay-generation cut. We deal with the overall LP considering the RECIFE-MILP formulation (2014 version) in which all binary variables are fixed. Indeed, they are fixed by the respective dispatcher problems.

The whole iterative process will store a set of overall LP solutions. During the process, if we reach the computational time limit, we stop calculating. However, if at some point, we could not find any more new cut, we also pause the process. Finally, the best-so-far solution is returned.

## 7.5 Partial results and contributions

We test the proposed approach on artificial networks of increasing size to assess its scalability. Preliminary results are promising in networks including up to seven stations. Besides, we assume that each train repeats its schedule everyday in a week. Consider time zone from 00:00:00 to 00:02:00, part of the results from the coordinator problem for one of the stations are shown in Table 7-1.

```
<station id="station1">
  <borders>
    <border CourseID="100_0" Enter_TC="TC1_13" Exit_TC="TC1_1"/>
    <border CourseID="101_0" Enter_TC="TC2_1" Exit_TC="TC2_11"/>
    ...
  </borders>
  <precedences>
    <precedence Course_one="100_0" Course_two="200_0" PreclD="p1" TC="TC1_13" y="1"/>
    <precedence Course_one="100_0" Course_two="201_0" PreclD="p2" TC="TC1_13" y="1"/>
    <precedence Course_one="200_0" Course_two="201_0" PreclD="p9" TC="TC1_13" y="1"/>
    ...
  </precedences>
</station>
```

Table 7-1: Part of the result from the coordinator problem

In Table 7-1, we have a list of borders and a list of precedences for station 1. In the border list, a CourseID represents a train and the Enter\_TC (Exit\_TC) implies the border section where the train utilized for entering (exiting) the station. As to one precedence, it contains a pair of trains (Course\_one and Course\_two), the precedenceID, a border section and a y value: y equals to one means that the first train has the priority to use the border section. For convenience, we always store a precedence in the format of  $y=1$ .

The results shown in Table 7-1 are used as input for each related dispatcher problem in every iteration until the best solution is found or it reaches the time limit. Dispatchers should give a detailed schedule of trains including timings and routes.

In terms of delay-generation detection and cuts, an example is illustrated in Figure 7-3.

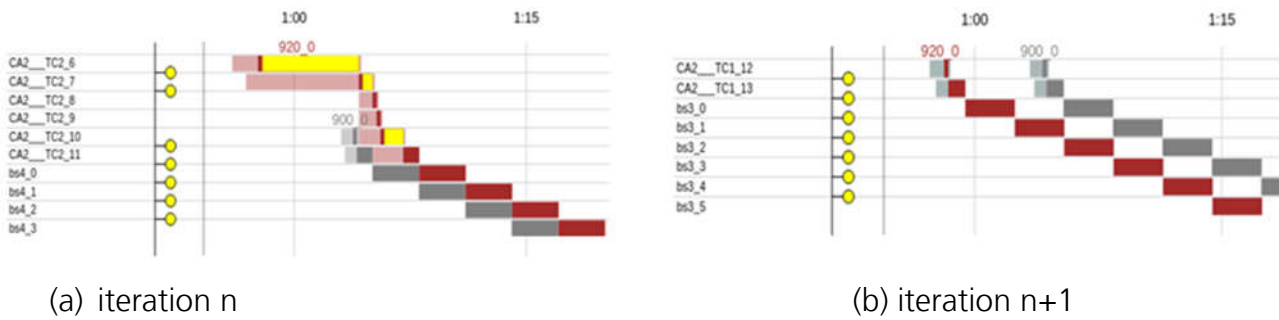

Figure 7-3: An example of a delay-generation cut

According to Gantt plot of the overall LP solution from iteration  $n$ , see Figure 7-3(a), we see that train 920\_0 had some delays (yellow blocks). Besides, for any resources shared by train 920\_0 and 900\_0, it is noticed that the ending utilization of 900\_0 is always followed by the starting utilization of 920\_0. It implies that train 920 had to slowly follow 900\_0, potentially leading to its delay. Thus, a feedback was sent to coordinator to regulate that: either i) 900\_0 and 920\_0 has to exchange the precedence, or ii) at least one of them has to use an alternative resource. The coordinator adapted this feedback and made new decisions. As shown in Figure 7-3(b), two trains used bs3 instead of bs4 in the next iteration, together with an exchanged precedence. In this new solution, no train had delay.

The main contributions of our work are the following: i) we study a collaborative level of the rtRTMP other than the wide-studied single area problem; ii) we design an iterative algorithm to solve our problem, in which the decisions of the coordinator are passed and kept as precisely as possible to dispatchers. A subset of cuts is defined when infeasibility occurs.

In this paper, we study the coordinator and dispatching problems for a collaborative version of the rtRTMP. The proposed algorithm can solve large scale instances efficiently. For our future works, we will implement our approach to real-life studies. We could also relax some assumptions, e.g., the sequence of control areas traversed by a train is not fixed.

## 7.6 References

- [1] Paola Pellegrini, Grégory Marlière, Raffaele Pesenti, and Joaquin Rodriguez. RECIEF-MILP: An effective MILP-based heuristic for the real-time railway traffic management problem. *IEEE Transactions on Intelligent Transportation Systems*, 16(5): 2609-2619, 2015.
- [2] Wei Fang, Shengxiang Yang, and Xin Yao. A survey on problem models and solution approaches to rescheduling in railway networks. *Transportation Systems*, 16(6): 2997-3016, 2015.
- [3] Pellegrini, P., Marlière, G., & Rodriguez, J. A detailed analysis of the actual impact of real-time railway traffic management optimization. *Journal of Rail Transport Planning & Management*, 6(1), 13-31, 2016.
- [4] Pellegrini, P., Pesenti, R., & Rodriguez, J. Efficient train re-routing and rescheduling: Valid inequalities and reformulation of RECIFE-MILP. *Transportation Research Part B: Methodological*, 120, 33-48, 2019.

## 7.7 Acknowledgments

This project X2Rail-4 has received funding from the Shift2Rail Joint Undertaking (JU) under grant agreement No. 881806. The JU receives support from the European Union's Horizon 2020 research and innovation programme and the Shift2Rail JU members other than the Union.

Disclaimer: This dissemination of results reflects only the authors' view and the Shift2Rail Joint Undertaking is not responsible for any use that may be made of the information it contains.



## 7.8 Authors



**Xiajie Yi** obtained the degree of Master in Engineering (specialization: Logistics Engineering) from Shanghai University, Shanghai, in 2016, and received her Ph.D. degree in Business Economics from Ghent University, Ghent, Belgium, in 2020. After that and until now, she joins Institut de Recherche Technologique Railenum as a post-doc researcher. Her current research activity lies in real-time railway traffic management problems.

E-Mail: [xiajie.yi@railenum.eu](mailto:xiajie.yi@railenum.eu)



**Grégory Marlière** is an IT engineer, he has 20 years of experience in the fields of rail traffic simulation and optimization. He has been involved in multiple European and national projects

E-Mail: [gregory.marliere@univ-eiffel.fr](mailto:gregory.marliere@univ-eiffel.fr)



**Paola Pellegrini** received the Ph.D. degree in mathematics for economics from Ca' Foscari University, Venice, Italy, in 2007. She is currently a Research Director at the Université Gustave Eiffel (ex IFSTTAR), Lille Campus, France. She has been a Visiting Researcher at the University of Arizona (USA) and a Postdoctoral Researcher at the University of Trieste and Ca' Foscari University (Italy) and at the research institute IRIDIA (Belgium). She has participated in research projects in the field of mathematical optimization, air traffic management, and railway transportation. She has published the results of her research studies in several scientific journal articles, book chapters, and conference papers.

paola.pellegrini@univ-eiffel.fr



**Joaquin Rodriguez** received the Ph.D. degree in computer science at the University of Compiègne, Compiègne, France, in 1985. He is a Research Director at the Université Gustave Eiffel (ex IFSTTAR), Lille Campus, France. He is responsible for the traffic management team. He has 20 years of experience in coordinating industrial and academic research projects dealing with railway traffic management, capacity analysis, diagnosis, and safety. He has developed several decision support tools in transportation applications: real-time train circulation management in railway nodes, simulation of guideway transit systems, and model-based diagnosis of electronic devices.

joaquin.rodriguez@univ-eiffel.fr



**Raffaele Pesenti** received the Ph.D. degree in systems sciences at the University of Genova, Genova, Italy. He is a Full Professor of operations research at the Department of Management, Ca' Foscari University, Venice, Italy. His major area of research is management of complex systems with application in transportation and logistics. The interests in this field are devoted to the study of the strategic and analytical elements of the systems design and to the development of models and methods that may find application in the day-by-day operations. His works appear on some of the highest impact journals in the field.

pesenti@unive.it

## 8 Performance evaluation of data collection and forwarding in NEWNECTAR architecture based on a reconfigurable wireless transceiver

*Dereje Mechal Molla, Université Gustave Eiffel, IFSTTAR, Villeneuve d'Ascq, France*

*Ali Sabra, IRT RAILENIUM, Famars, France*

*Hakim Badis, Université Gustave Eiffel, IFSTTAR, Villeneuve d'Ascq, France*

*Marion Berbineau Université Gustave Eiffel, IFSTTAR, Villeneuve d'Ascq, France*

### 8.1 Introduction

Railway infrastructure is a complex system that includes different structures, tracks, buildings, and equipment to support the railway line. Monitoring each element of the railway infrastructure is a crucial and vital task for transport safety, infrastructure sustainability and infrastructure adaptability or flexibility to existing and emerging needs. However, monitoring the health of such infrastructure is challenging due to the need to collect various data from each component that are installed in different areas including in places that are difficult or impossible to access. The development of Wireless Sensor Networks (WSNs) and the large set of new wireless communication technologies have made possible to monitor complex infrastructures in the railway sector by allowing the collection of sensor data remotely. Indeed, distinct wireless sensor nodes utilizing different wireless technologies can be installed in the railway infrastructure and form heterogeneous WSN domains. The data collection process from these heterogeneous domains requires managing several sensor nodes with different characteristics. This task poses some challenges related with different topics such as energy consumption, limited radio frequency spectrum bands, resource optimization, Quality of Service (QoS), etc. Thus, to alleviate these challenges and perform efficient data collection, a moving vehicle equipped with multiple technologies capable of visiting each WSN domain involved in the railway infrastructure can be used. In addition, these challenges can be addressed by designing a new WSN infrastructure that exploits Software Defined Radio (SDR) approaches at the physical layer and Software Defined Networks (SDN) at higher layers.

Consequently, we have proposed a new WSN infrastructure formed by independently deployed WSNs with heterogeneous wireless communication technologies. It is called a New generation of adaptable Wireless sensor NEtwork for wayside objeCTs in rAilway enviRonments (NEWNECTAR) [1]. It is an adaptive data collection and forwarding strategy based on the software-defined approaches at the physical and higher layers. It involves the use of a Universal Sink Gateway (USG) mounted on a moving vehicle (trains) and is designed based on SDR capabilities to allow the data collection from different wireless sensor nodes through a reconfiguration process. The collected data is forwarded to a remote control center (such as a cloud server) using long-range cellular wireless technologies. Moreover, the NEWNECTAR uses the SDN paradigm to control network and sink node failures that might occur due to several factors such as environment, battery drainage, natural or man-made disasters.

In the following, we first present the general architecture of NEWNECTAR with a brief description of its main parts. Then, we show the system architecture of a testbed and a couple



of test results which prove the functionality of our demonstrator at its current stage for data collection and forwarding. Finally, the conclusions obtained from this research work are exposed including the future work to be done to improve the current demonstrator.

## 8.2 NEWNECTAR demonstrator architecture

The NEWNECTAR architecture has three main parts: the WSN domains responsible for the actual data collection from railway objects, the USGs mounted on the trains and the remote cloud to host servers and base stations. Figure 8-1 demonstrates the global view of NEWNECTAR architecture [1]. The sensors in the WSN domains (or clusters where each cluster comprises several sensors and a cluster head (CH) to manage the activities of sensors) along the railway line collect data from the environment and send/route data to the CH. Each USG, mounted on trains, collects data either directly from sensor nodes (end devices) or collects aggregated data from CHs while moving on the railway line until it reaches a data upload zone where high-power technologies are accessible. The USG then forwards the collected data to the cloud server from the data upload zone. The communication between each entity (WSN nodes, USG and cloud service providers – Internet Service Provider (ISP) base stations) can be carried out using different wireless technologies. On the one hand, in NEWNECTAR, WSN nodes, in general communicate with USGs using short-range technologies such as IEEE 802.15.4, Bluetooth Low Energy (BLE), etc., sometimes using long-range low-power technologies such as Long-Range (LoRa). On the other hand, USGs communicate with the cloud through long-range high-power technologies such as 3GPP 3G, LTE/LTE-A, 4G/5G, etc., sometimes using medium-range technologies such as WiFi, and low-power wide area network technologies such as NB-IoT, LoRa, etc.

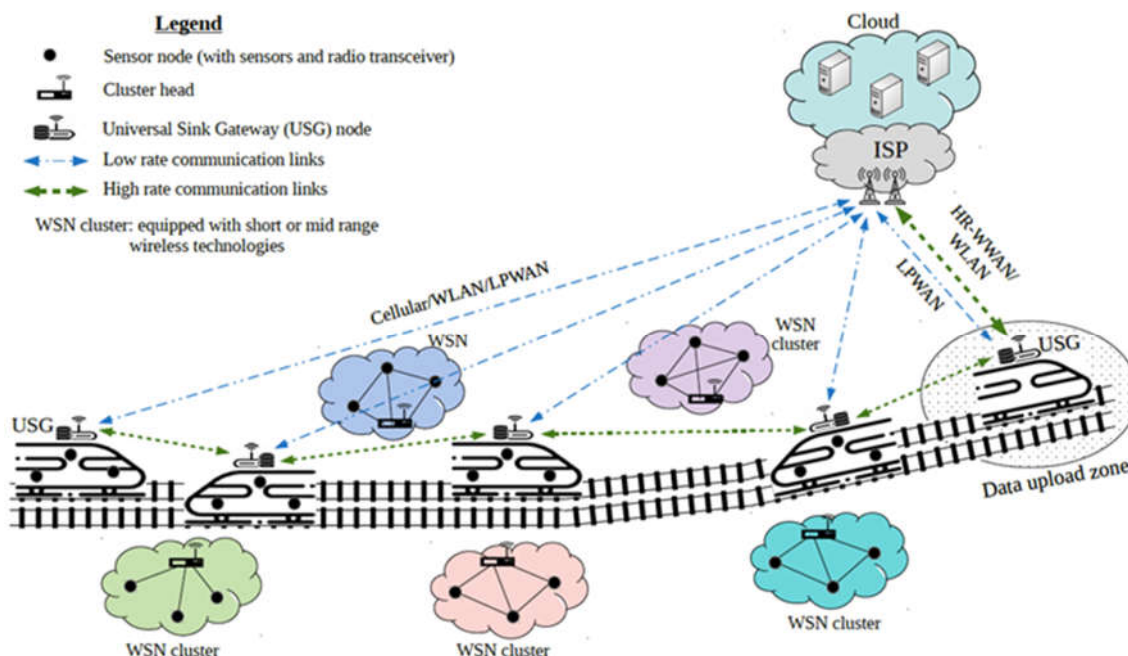

Figure 8-1: General architecture of NEWNECTAR demonstrator [1].

The participation of multiple wireless technologies in the data collection and forwarding process creates challenges on the design of the USG node. In fact, it can be designed by aggregating multiple wireless transceivers, which will increase the cost and complexity, and suffers from low scalability and low programmability/configurability issues. However, NEWNECTAR uses a

reconfigurable/programmable device based on General Purpose Processor (GPP)-based SDR platform to design the USG. This design allows the USG to reconfigure itself to a target wireless technology whenever required. Due to the short distance coverage of most wireless technologies used by sensor nodes for data collection, a pre-recorded information on the USG's database is used to perform the reconfiguration process. However, for data forwarding, we consider cognitive radio techniques to search for available long-range wireless technologies and switch to new technology. Another challenge is the reconfiguration of the network when required, for example, during network or node failure. NEWNECTAR proposes to perform network reconfiguration using SDN paradigm where alternate multi-hop routes can be forwarded to USGs from a central controller located in the cloud. These two challenges are considered and explained in this paper.

### 8.3 NEWNECTAR demonstrator testbed

To illustrate the functionality of the NEWNECTAR demonstrator, a testbed is prepared as depicted in Figure 8-2. For simplicity, the general architecture is first grouped into three layers: WSNs layer, USGs network layer and cloud layer, which perform the functions stated for the three parts described above, respectively. The testbed consists of two WSN clusters based on IEEE 802.15.4 and LoRa technologies at the WSNs layer; two USG nodes at the USGs network layer; and MQTT broker, database and application servers at the cloud layer. Each USG implements IEEE 802.15.4 and LoRa wireless technologies to communicate with the WSN clusters, as well as Wi-Fi and LTE technologies to communicate with the respective base stations of radio access network (RAN) providers. The USG also implements a second LoRa and LTE-Direct technologies, which are utilized to exchange routing information and perform multi-hop routing, respectively. However, we limit the experimental demonstration only to evaluate the performance of USG while reconfiguring its radio interfaces towards the WSN node technologies: IEEE 802.15.4 and LoRa, and forwarding data through LTE.

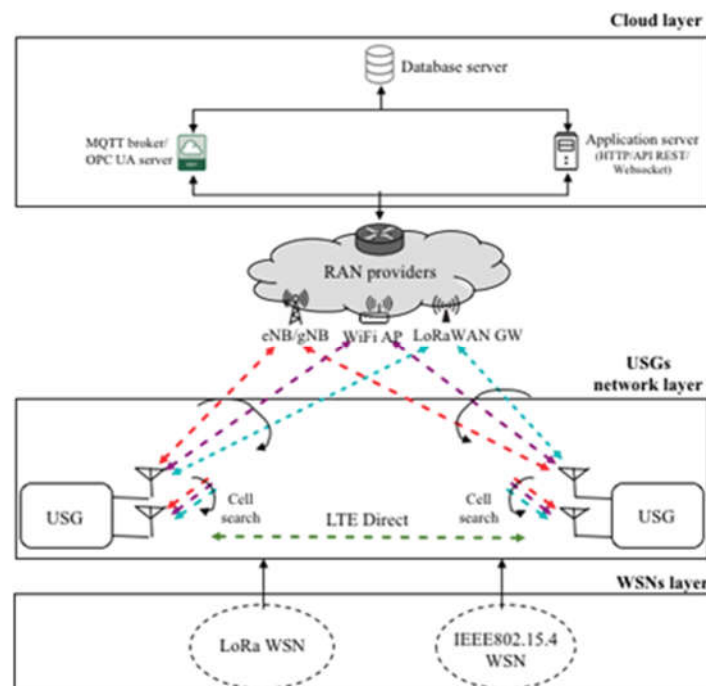

Figure 8-2: NEWNECTAR demonstrator testbed.

## 8.4 Performance evaluation

Based on the testbed depicted in Figure 8-2, we experimentally evaluated the performance of the NEWNECTAR demonstrator for two scenarios: USG's reconfiguration capability for data collection and USG's performance for forwarding data.

### 8.4.1 USG reconfiguration capability for data collection

As stated in the previously section, the USG is required to reconfigure itself to different radio access technologies so that it can exchange data with the different sensor nodes that are operating over a specific radio access. Therefore, we demonstrate here the capability of the USG to reconfigure itself to different communication systems technologies. Moreover, the GPP performs the wireless technologies slowly compared to other processors [1]. Consequently, the USG reconfiguration process is not instantaneous. This means that the reconfiguration of the USG requires some time that has to be taken into account while analyzing USG's performance for data collection. The reconfiguration delay and the distance traveled by the train must be anticipated by the USG due to the limited coverage zone of the technologies over which the sensors are transmitting data.

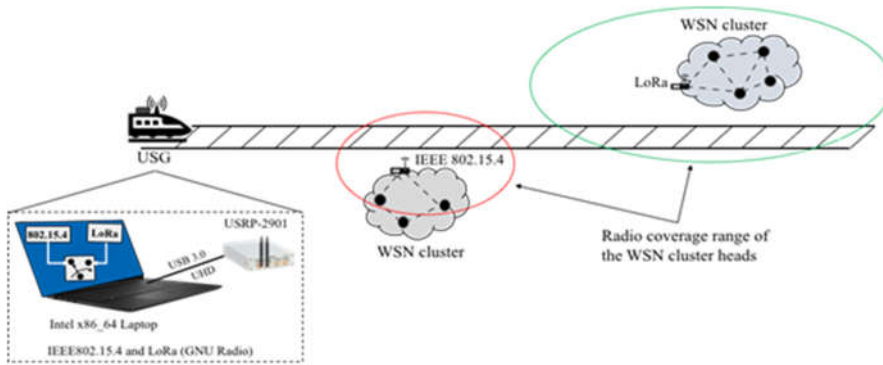

Figure 8-3: USG communication systems switching test setup.

A testbed has been set up using one x64\_86 laptop performing LoRa and IEEE 802.15.4 systems from [2] and [3] respectively and connected to a USRP B210 [4] SDR card via USB cable. Reconfiguration delay from LoRa to IEEE 802.15.4 and vice versa is measured and the result with 60 repetition is shown in Table 8-1.

Table 8-1. Switching time (sec) from LoRa to IEEE 802.15.4 and vice versa

	min	max	mean	Standard deviation
LoRa to IEEE 802.15.4	3.39	3.64	3.51	0.0581
IEEE 802.15.4 to LoRa	3.1	3.3	3.2	0.0522

According to Table 8-1, when the USG switches itself from LoRa to IEEE 802.15.4 technology, the maximum switching time is 3.64 seconds. If considering three different train speeds, 80 km/h (Urban), 180 km/h (Intercity) and 250 km/h (Rural), the maximum switching delay is equivalent to 80.88, 182 and 252.778 meters of train travel distances, respectively. Given that the IEEE 802.15.4 is a short-range technology, the USG needs to start reconfiguring itself at

least before the distances stated above, depending on the train speeds. This guarantees the maximum time for data exchange between the USG and the IEEE 802.15.4 node.

Regarding the switching delay from IEEE 802.15.4 to LoRa, the maximum value is 3.3 sec. This means that, if considering the same speeds as stated earlier, the train will travel distances of around 73.326, 165 and 229.167 meters. However, given that LoRa is a long-range technology, the USG can start its reconfiguration process to LoRa even after reaching the latter's technology coverage zone. Nevertheless, the USG should still take the switching delay into account for time-critical data transmission.

### 8.4.2 USG data forwarding performance

After data collection, the train will have to forward the data to the cloud server. Considering that the amount of data to be collected is high, we find that a high-rate, long-range technology such as LTE is suitable for forwarding such data. This is also due to the fact that the LTE system is robust against bad channel conditions (high speed, low Signal-to-Noise Ratio (SNR), etc.) [5], which might be the case for railway communication. In order to test the USG's capability to forward data over LTE, we conducted an in-lab experimental study.

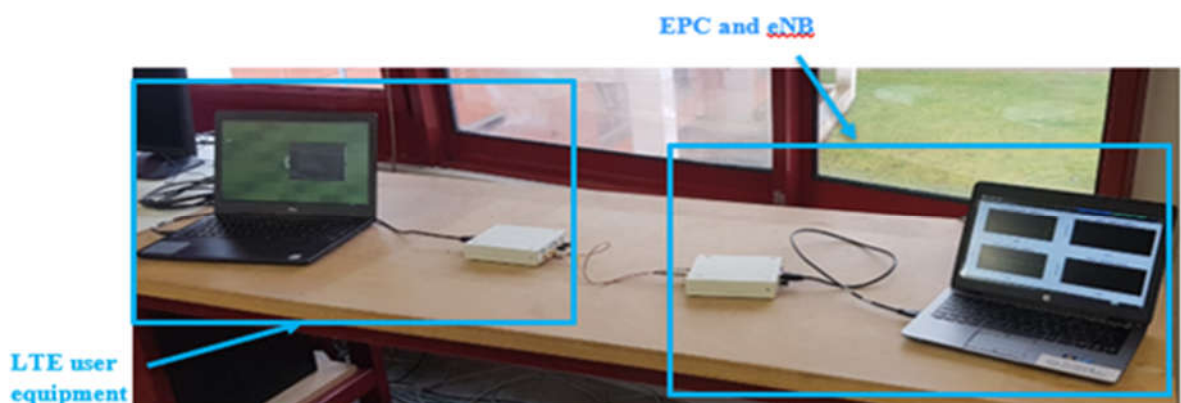

Figure 8-4: LTE data forwarding testbed.

As shown in Figure 8-4, the testbed consists of one USG node designed using x64\_x86 PC, USRP B210, coaxial cable and 30 dB attenuator. The software part of the USG is implemented based on srsRAN [6] for LTE emulation. The RAN base-station (eNodeB) at the cloud is formed using USRP B210 SDR board, coaxial cable and 30 dB attenuator. The aim of the experiment is to test the data forwarding capability (in terms of throughput, packet loss, and transmission delay) of USG through LTE link under different channel conditions and speed of train. The radio channel effects considered are the Doppler effect that occurs due to the train mobility and multipath due to the signal spread into multiple rays. Also, we test the data forwarding delay according to the amount of data to be transferred and the channel condition. We consider 1 Mbyte and 10 Mbytes of data to transmit. To mimic the time dispersion of the channel, we include a software generated Extended Vehicular A (EVA) channel model [7] to the LTE signal for all the tests. The LTE system is configured with 50 resource blocks (10 MHz of bandwidth). Iperf3 [8] network tool is used to transmit IP traffic at 10 Mbits/s from USG node to the cloud.

Table 8-2 shows the experimental test results of USG data forwarding over the LTE link. Obviously, the faster the train, the lower is the throughput. The results show that, the throughput starts to be heavily affected with train speeds above 180 km/h. Moreover, compared to 180 km/h (from 10 Mbits/s to 7.16 Mbits/s), at 250 km/h, the average throughput decreases severely (from 10 Mbits/s to around 2 Mbits/s) for 1 Mbyte. Similarly, there are no packets lost while the train is stationary and moving at 80 km/h. At 180 km/h, though the packet loss is very less for transmitting small amount of data, significant number of packets are lost transmitting 10 Mbytes of data. For the delay test, the results show that when moving at the maximum considered speed (250 km/h), the train should be in a good cell coverage for at least 611 meters in the case of 10 Mbytes data transmission, whereas for the 1 Mbyte case, 135 meters of good cell coverage are enough for the same speed.

Table 8-2. Data forwarding performance under time and frequency dispersion

	min				max				average				Standard deviation			
	0	80	180	250	0	80	180	250	0	80	180	250	0	80	180	250
Speed of train (km/h)	0	80	180	250	0	80	180	250	0	80	180	250	0	80	180	250
Throughput (Mbits/s)	9.5	9.3	6.1	1.02	9.88	9.79	7.89	2.95	9.83	9.59	7.16	2.08	0.07	0.09	0.26	0.45
	9.6	9.6	6.1	1.24	10.3	10.2	7.9	3.71	9.97	9.96	7.16	2.7	0.14	0.13	0.26	0.4
Packet Loss (%)	0	0	0	48	0	0	3	66	0	0	0.81	58.6	0	0	0	0.03
	0	0	23	66	0	0	26	76	0	0	24.5	71	0	0	0	0.26
Transmission duration (s)	0.8	0.8	1.08	1.4	0.81	0.83	1.33	1.95	0.79	0.81	1.14	1.56	0	0	0.03	0.2
	7.6	7.6	8.21	8.17	7.62	7.68	8.28	8.79	7.65	7.66	8.24	8.6	0.01	0.01	0.01	0.16
Equivalent Distance (m)						18	136	135								

NOTE: Shaded cells are for 1 Mbyte of data; white cells are for 10 Mbytes of data transmission.

## 8.5 Conclusions

We experimentally demonstrated the NEWNECTAR demonstrator developed for optimizing data collection and forwarding processes in the railway sector. It exploits the two novel software defined approaches where SDR technology is used to design a USG node and considers spectrum sensing and radio access reconfigurability based on cognitive radio. At the network level, it relies on the SDN paradigm for network management and policy enforcement. As the core element of NEWNECTAR is the USG node, two demonstration scenarios were experimentally presented to show its reconfiguration capability in order to communicate with WSN nodes for data collection, and cloud base stations to forward collected data. The results demonstrate that for USG to collect data from short-range technologies, it should start switching its radio interfaces before entering the coverage range of short-range technologies for high-speed trains. Moreover, we also demonstrated that USG can perform data forwarding through the LTE link.

In future work, we plan to show the reconfiguration of USG node to data forwarding technologies through a spectrum sensing algorithm. In addition, we plan to conduct experimental demonstrations to perform reconfiguration of USGs network through SDN paradigm. Each USG will receive routing information from a central controller (known as SDN

controller) located in the cloud. For this part, an experimental test to show the communication between USG and SDN controller will be performed using the MQTT protocol and LoRa communication technology. In addition, a link between USG nodes will be established via LTE-direct and test for multi-hop routing functionality.

## 8.6 References

- [1] D. M. Molla, H. Badis, L. George and M. Berbineau, "NEWNECTAR: A New generation of adaptable wireless sensor network for wayside objects in Railway environments", NETS4WORKSHOP, Springer, FRANCE. NOV 2020.
- [2] [Wi-Fi 15.4] Bloessl, Bastian, et al. "A GNU radio-based IEEE 802.15. 4 testbed." 12. GI/ITG KuVS Fachgespräch Drahtlose Sensornetze (FGSN 2013) (2013): 37-40.
- [3] Tapparel, Joachim, et al. "An open-source LoRa physical layer prototype on GNU radio." 2020 IEEE 21st Interna. Workshop on Signal Processing Advances in Wireless Communications (SPAWC). IEEE, 2020.
- [4] NI-2901 <https://www.ni.com/fr-fr/support/model.usrp-2901.htm>. Accessed 10/02/2022
- [5] A. Elnashar and M. A. El-Saidny, "Looking at LTE in Practice: A Performance Analysis of the LTE System Based on Field Test Results," in IEEE Vehicular Technology Magazine, vol. 8, no. 3, pp. 81-92, Sept. 2013, doi: 10.1109/MVT.2013.2268334.
- [6] I. Gomez-Miguel, et al. " srsLTE: an open-source platform for LTE evolution and experimentation." ACM WiNTECH, pp. 25-32, OCT 2016.
- [7] 3GPP, « 3GPP TS 36.101. "Evolved Universal Terrestrial Radio Access (E-UTRA); User Equipment (UE) Radio Transmission and Reception." Available: <https://www.3gpp.org>. [Access on 09 09 2021].
- [8] iperf network test tool. Available online in <https://iperf.fr/iperf-download.php> Accessed 20/05/2022

## 8.7 Acknowledgments

This project X2Rail-4 has received funding from the Shift2Rail Joint Undertaking (JU) under grant agreement No. 881806. The JU receives support from the European Union's Horizon 2020 research and innovation programme and the Shift2Rail JU members other than the Union.

Disclaimer: This dissemination of results reflects only the authors' view and the Shift2Rail Joint Undertaking is not responsible for any use that may be made of the information it contains.



## 8.8 Authors



**Dereje Mechal Molla** received the B.S. degree in electrical engineering from Hawassa University, Hawassa, Ethiopia in 2008; and the M.S. degree in Telematics from Politecnico di Torino, Turin, Italy in 2013 and the Ph.D. degree in computer science from Gustave Eiffel University, Marne la Vallée, France in 2022. From 2014 to 2018, he was a lecturer at the communication engineering stream, Hawassa University Institute of Technology, Hawassa, Ethiopia. His research interest includes to study the performance of SDR platforms as a wireless transceiver for WSNs and IoT, integration of SDR and software defined networking for wireless networks.

E-Mail: dereje-mechal.molla@univ-eiffel.fr



**Ali Sabra** received the Bachelor of Engineering in Information and communication Technology from the Belarusian State University of Informatics and Radioelectronics, Minsk, Belarus, and the M. Eng. degree from the University of Burgundy, Dijon, France, in 2018 and 2019 respectively. He participated in Emulradio4Rail, X2Rail-4 and X2Rail-5 European railway-related projects. He is currently working as a R&D engineer at Railenium. His research interests include radio channel characterization and emulation, cognitive radio, software defined radio, LTE, 5G and railway communications.

E-Mail: ali.sabra@railenium.eu



**Hakim Badis** received the M.S. degree in Distributed Computing from Paris-sud University, Orsay, France in 2002, and the Ph.D. degree in Mobile Networks from LRI, Orsay, France in 2005. He is currently associate Professor in computer science at Gustave Eiffel University, researcher at LIGM lab specialized in next generation wireless networks, multi-hop and IoT sensor networks, smart antennas (MIMO, etc.), software defined radio, software defined networking, discrete mathematics (graph theory, information theory, etc.), distributed algorithms and complexity.

E-Mail: hakim.badis@univ-eiffel.fr



**Marion Berbineau** (Member, IEEE) received the Engineer degree from Polytech'Lille (EUDIL) in informatics, electronics, automatics, in 1986, and the Ph.D. degree in electronics from the University of Lille, France, in 1989. She was the Director of the Leost Laboratory, from 2000 to 2013, and the Deputy Director of the COSYS Department, from 2013 to 2017. She is currently the Research Director of Université Gustave Eiffel (previously Ifsttar and Inrets), since 2000. In addition to research activities and supervision of Ph.D. students, she coordinates railway research at Université Gustave Eiffel. She is the Pole Leader of the Intelligent Mobility pole of European Railway Research Network of Excellence (Eurnex). Her current research interests include wireless communications for connected and automatic vehicles (trains and cars) (radio propagation, channel characterization and modeling, MCM, MIMO, ITS-G5, GSM-R, LTE, and 5G NR). She has already participated to a lot of European and national research projects since 1990. She is also the Project Leader of the Emulradio4Rail Project in the framework of Shift2Rail IP2 and involved in several other projects (X2Rail-3, X2Rail-4, and X2Rail-5). She is on the reserve list of the Scientific Council of the Shift2Rail Program.

E-Mail: [marion.berbineau@univ-eiffel.f](mailto:marion.berbineau@univ-eiffel.fr)





# 9 Electromagnetic Energy Harvesting and Wireless Power Transfer Novel Concepts for the Railway Environment

*Mohammed Kalaagi ,IRT RAILENIUM, Famars, France*

*Divitha Seetharamdoo, Université Gustave Eiffel, IFSTTAR, Villeneuve d'Ascq, France*

## 9.1 Abstract

The interest for electric energy power supply to different components in the railway infrastructure, has become an interesting research topic with the gain of popularity for railway systems. To develop a smart, reliable, safe and autonomous railway system, specially with the rise of different technologies such as Internet of things (IoT) devices and wireless sensor nodes (WSN), electric power supply is needed for such that devices are implemented in a reliable and autonomous manner. Energy harvesting and wireless power transfer (WPT) technologies can be a key element for power supply to such devices, to build a sufficient and convenient system. The aim of this work is to develop novel concepts, to enhance the potential and performance of EM energy harvesting and WPT technologies which can be compatible for the application in the railway environment.

## 9.2 Introduction

Railway transportation has become an essential method of transport between regions for many people around the world, this especially due to its characteristics such as high safety, reasonable economical value, being a low carbon mode, resource efficient transport transport and environmental friendliness. Moreover, the enhancement and growth of the railway environment is essential specially with the rise of different smart technologies such as IoT, wireless sensor networks (WSN) and 5G communication systems [1] [2]. These technologies can help enhance the reliability, security and maintenance and give rise to smart railway systems. However, the need of power supply for systems such as WSN or IoT devices on the railway system can be a challenge, specially to enable autonomous and more reliable systems for implementation and deployment. EM energy harvesting (EH) and WPT technologies can be key to enable autonomous WSN on the railway infrastructure [3].

For the railway application, many challenges and limitations can arise for EM energy harvesting devices. Rectenna systems for low microwave frequencies, can be of low efficiency and difficult to implement. On the other hand, for WPT technologies, line of sight can be a major challenge for such applications. Metasurfaces have gained remarkable interest in the field of electromagnetics for many researchers in the past years [4]. This is many for their exceptional physical properties, characteristics and wide generality design approach, specially in terms of wave control and manipulation in various manner depending on the engineered design and application needed. A wide range of characteristics in terms of wave control have been given in the literature for metasurface designs, from anomalous wave control, beam splitting, focusing, wavefront manipulation, absorption, energy harvesting, retro-reflection and many more.

In this work, we introduce the design of retrodirective metasurfaces following the generalized phase law of reflection, which can be remarkable in terms of tracking and localization enhancement specially from the oblique angular aspect [5] [6]. A novel concept and approach in terms of EM EH, for enhancing the performances of rectenna system is given. The concept is based on focusing metasurfaces in which a well designed, high efficient and miniaturized metasurface focuses the EM energy present in the far field at a focal point at a distance from the metasurface. An off the shelf rectenna system is then implemented at the spot to harvest the energy. This concept can be a remarkable approach to overcome the challenge and limitation of low efficient ambient EM energy in the surrounding environment, and enhance the performances of low efficient rectenna systems [7].

### 9.3 Wireless power transfer: use case and testing scenario

A typical use case for the WPT is when the sensor node to be powered is located onboard a moving train and the powering and transmitting unit is located on the trackside. The inlab test emulation of the angular variation between the beams of the emitting and receiving systems will be done in an anechoic chamber with the classical turnstands used for radiation pattern measurements. Such a scenario is depicted in the Figure 9-1 below.

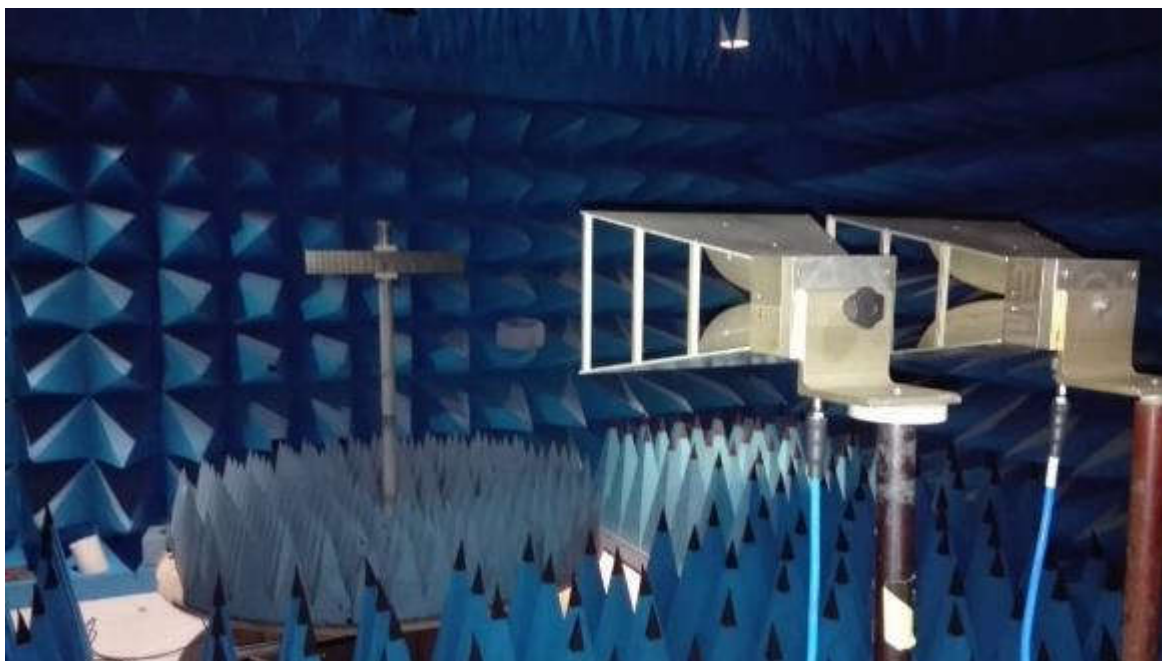

Figure 9-1: Turnstand in an EM anechoic chamber with an angular resolution of  $1^\circ$  in sub 6 GHz frequency bands (Measurements of Monostatic radar cross section (RCS) using two antennas one transmitting and one receiving)

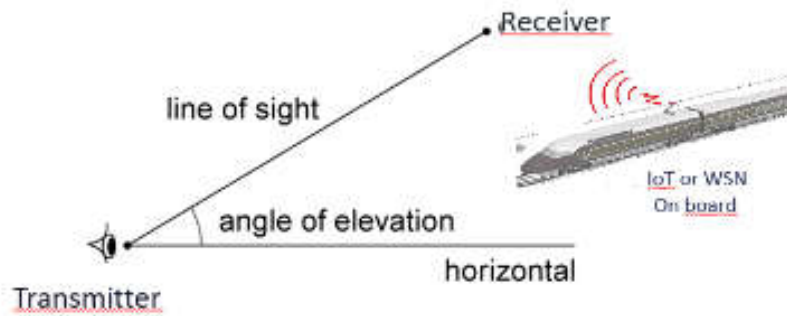

Figure 9-2: Use case scenario for WPT for IoT or WSN on board units

Figure 9-2 shows a use scenario for retrodirective metasurfaces where mobility and line of sight can be a challenge to power IoT and WSN on board of a railway. The receiver in this case is the WSN or IoT device on board of the train along side the retrodirective metasurface.

Wireless powering of sensors with WPT is a good solution for IoT devices accounting for mobility for its ease of implementation, battery-less configuration resulting in low maintenance costs. One of the main challenges of WPT is the design of the radiating elements used to transmit and receive power, which can support tracking and localizing of sensor nodes to ensure that the power is properly and selectively directed. The concept of the proposed WPT solution is depicted in the figure below.

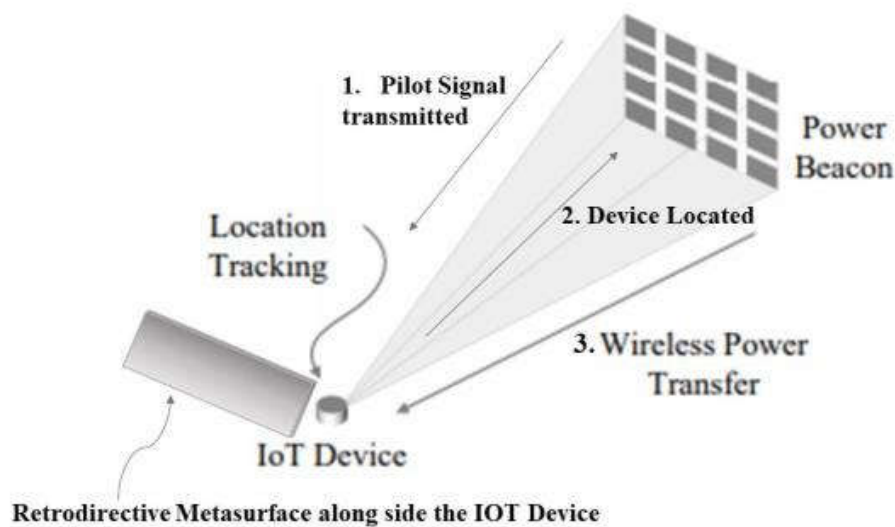

Figure 9-3: Wireless Power Transfer concept for tracking an IoT device to supply along with the usage of a device with retrodirective properties<sup>4</sup>

Our WPT system will particularly address this problem with a focus on providing these tracking and power redirection functions at a low-energy cost, based on technological solutions that can be passive. The system consists of: A receiving antenna, an emitting antenna and a prototyped device with retrodirective properties such that power is redirected at the sensor node (Figures 9-4 and 9-5).

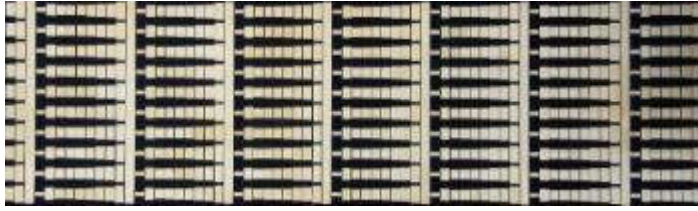

Figure 9-4: Multi-Angle retrodirective metasurface [6]

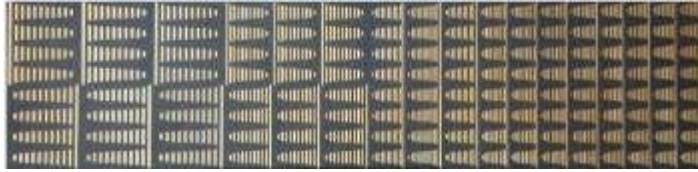

Figure 9-5: Wide band Multi-Angle cascading retrodirective metasurface [5]

Figure 9-4 and 9-5 show different designs of retrodirective metasurfaces functioning at various angles simultaneously which are printed on top of a Rogers Duroid substrate of permittivity 2.2 and thickness 1.6mm. In Figure 9-5 the metasurface is designed based on the cascading method, various super-cell designs each at a specific angle are modelled following the generalized phase law of reflection and superposed to form a wideband multi angle functional retrodirective metasurface. The equation of the generalized phase law of reflection [5] is given by (1):

$$\sin \theta_r - \sin \theta_i = \frac{\lambda}{2\pi} \frac{\partial \phi}{\partial x} \quad (\text{Eq. 9-1})$$

For retroreflection,  $\theta_r = -\theta_i$  thus the equation of the generalized is integrated to determine the periodicity of the super cell design given by (2):

$$L_x = \frac{\lambda}{2 \sin \theta} \quad (\text{Eq. 9-2})$$

$\theta_r$  is the angle of reflection,  $\theta_i$  is the angle of incidence,  $\lambda$  is the wavelength and  $L_x$  is the periodicity of the super cell design. In Figure 9-4 the metasurface is designed following the same procedure of that of Figure 9-5 using the generalized phase law of reflection. In addition, the super-cell is given with high periodicity  $3\lambda$  to achieve multiple angle retro-reflection where surface impedance modulation is used to achieve a lossless multi-functional retrodirective metasurface. For the test cases the monostatic RCS is calculated and measurements are carried on in an anechoic chamber as shown in Figure 9-1.

The metasurface (Figure 9-4) is tested for retroreflection using two Vivaldi antennas implemented at the same point. The results of retroreflection are shown in Figure 9-6.

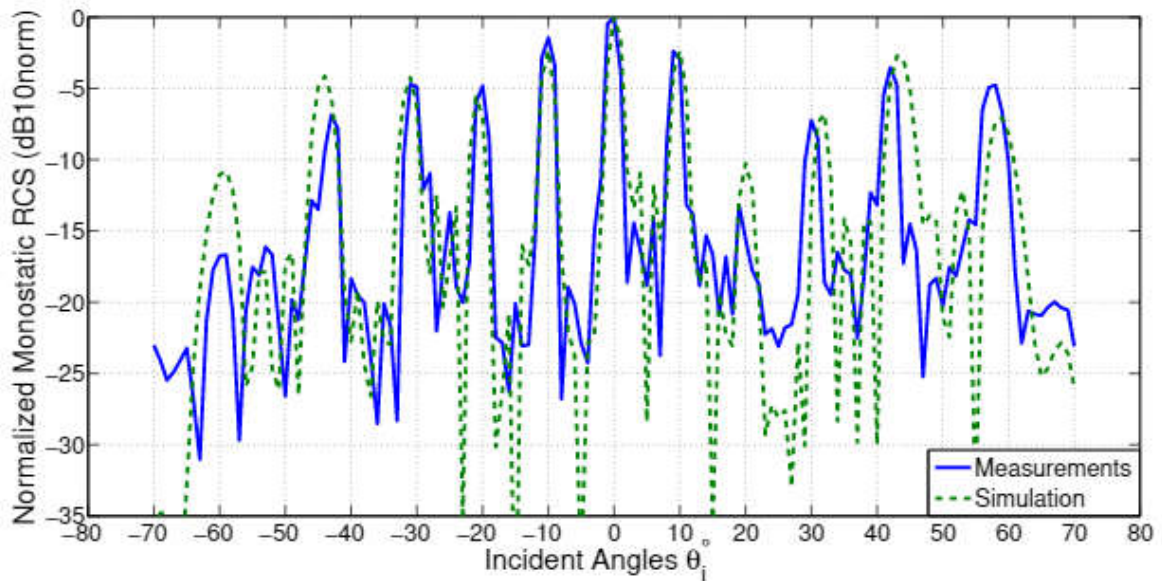

Figure 9-6: Monostatic RCS measurements of the metasurface compared to that of the simulation results5

The results in Figure 9-6 show high level of retroreflection at various oblique angles of incidence. This can be significant when implemented along side a sensor device for the enhancement of localization and tracking in WPT systems.

## 9.4 EM Energy Harvesting of Ambient Energy

Energy harvesting from electromagnetic ambient sources has been shown to be relevant in railway environments both at several frequency bands. The demonstrator proposed here is a device based on focusing metasurfaces which enhances the performance and efficiency of existing rectenna systems, which are used for harvesting energy from ambient signals from telecommunication systems.

Our demonstrator which integrates both the design antenna systems and rectifying circuits can be used to harvest new communication system ambient signals. The experiments and testing of our demonstrator have been carried on in the UGE laboratory and in our anechoic chamber located at the University of Lille in Villeneuve d'Ascq.

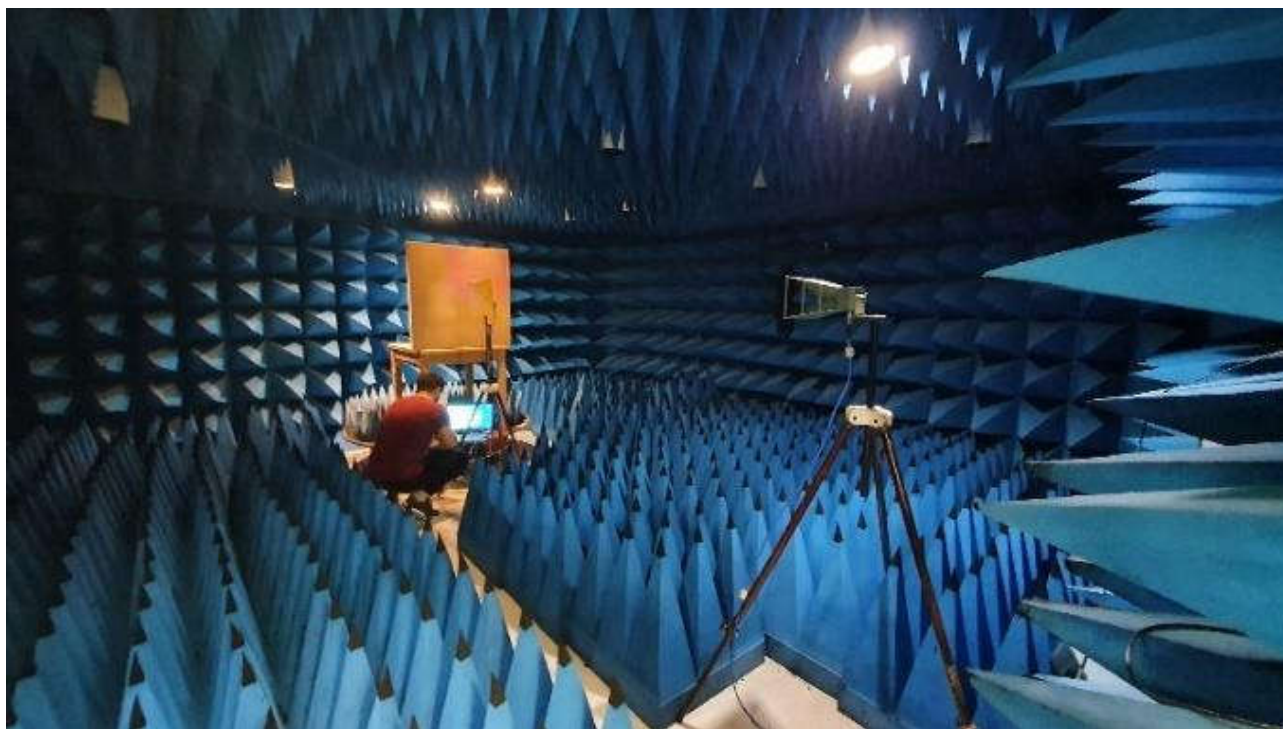

Figure 9-7: Anechoic chamber for experiment testing at the University of Lille 1

The anechoic chamber is used to carry on ideal measurements compared to that in the real environment specially for far-field electromagnetic measurements. For the test case we have used a transmitting antenna in the far-field and rectenna system at the receiving end along side our focusing metasurface over an average period of time of one minute. We have calculated the received power for different scenarios using the rectenna system alone and along side the device. The results are shown in Figure 9-8.

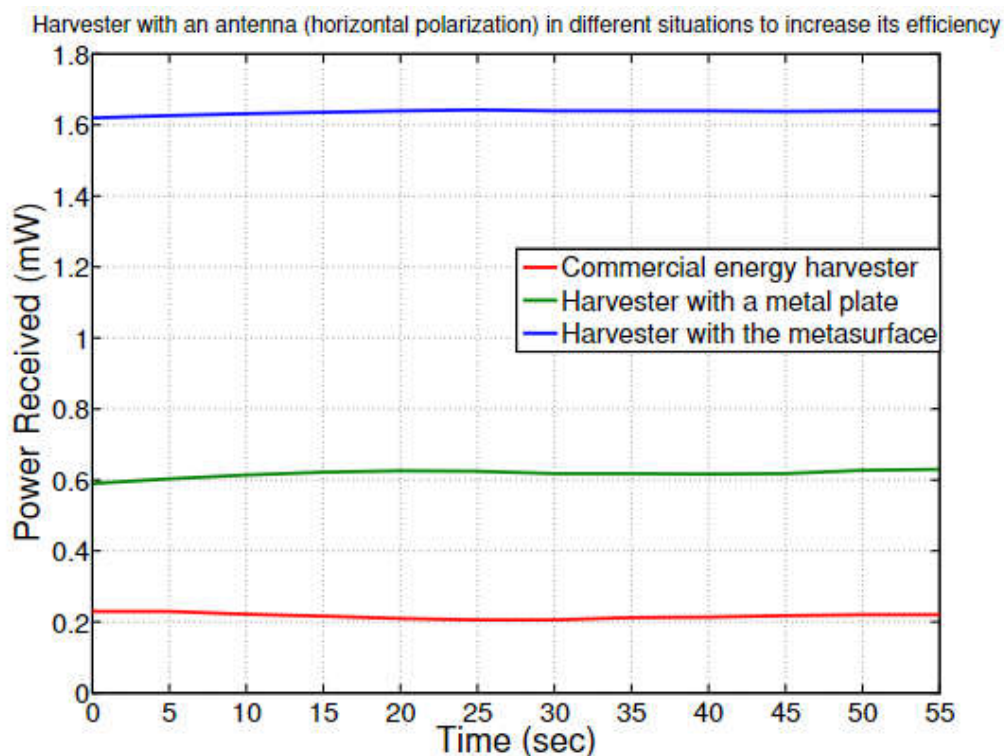

Figure 9-8: Three different test cases and scenarios of the power received by the rectenna

The device has shown remarkable results when integrated along side the rectenna system giving a gain of up to a factor 8 in linear compared to when a commercialized rectenna system is implemented alone. This concept can be an interesting solution in the field of EM energy harvesting specially for ambient energy environments where low power is received by the collector.<sup>6</sup>

## 9.5 Conclusion

Energy harvesting of ambient EM energy in a railway environment can be a challenge for different existing technologies specially rectenna systems. Moreover, the low efficiency and design complications at low frequencies can be a drawback for such devices. We proposed a novel concept and a focusing metasurface, to be a complementary solution to existing EM harvesting technologies and enhance their performances and make them more efficient. The device has shown remarkable results when integrated along side the rectenna system giving a gain of up to a factor 8 in linear compared to when a commercialized rectenna system is implemented alone.

On the other hand, for WPT technologies, Line of sight and tracking can be a challenge from the angular aspect for WPT systems, specially in the railway application. We proposed a solution using the remarkable physical properties of metasurfaces in terms of wave control following the generalized phase law. The aim was to design a metasurface capable of redirecting back the wave or signal in the same direction which can be useful in various applications. The challenge however was to design a passive retrodirective metasurface that can operate for multiple angles simultaneously which has been achieved using the surface impedance modulation and cascading technique. Such metasurfaces can be of great use for different application where tracking and localization need to be enhanced for different systems.

## 9.6 References

- [1] A. Hosseinkhani, D. Younesian, P. Eghbali, A. Moayedizadeh, and A. Fassih, "Sound and vibration energy harvesting for railway applications: A review on linear and nonlinear techniques," *Energy Reports*, vol. 7, pp. 852–874, 2021.
- [2] S. M. Rakshit, M. Hempel, P. Shrestha, F. Rezaei, H. Sharif, J. Punwani, and M. Stewart, "Energy analysis in deploying wireless sensor networks for on-board real-time railcar status monitoring," in *2015 Joint Rail Conference*. American Society of Mechanical Engineers, 2015, pp. 1–4.
- [3] H.-P. Tan, P. W. Lee, W. K. Seah, and Z. A. Eu, "Impact of power control in wireless sensor networks powered by ambient energy harvesting (wsn-heap) for railroad health monitoring," in *Advanced Information Networking and Applications Workshops, 2009. WAINA'09. Inter-national Conference on*. IEEE, 2009, pp. 804–809.
- [4] H.-T. Chen, A. J. Taylor, and N. Yu, "A review of metasurfaces: physics and applications," *Reports on Progress in Physics*, vol. 79, no. 7, p. 076401, 2016.
- [5] Mohammed Kalaagi and Divitha Seetharamdoo. "Multiangle retrodirective cascaded metasurface". *Journal of Applied Physics* 126 (10), 104901, 2019



- [6] Mohammed Kalaagi and Divitha Seetharamdoo. "Retrodirective metasurfaces from non-reciprocal to reciprocal using impedance modulation for high-super-cell-periodicity designs." *Applied Physics A* 126 (4), 1-7, 2020.
- [7] D. Surender, T. Khan, F. A. Talukdar, A. De, Y. M. Antar, and A. P. Freundorfer, "Key components of rectenna system: A comprehensive survey," *IETE Journal of Research*, pp.1–27, 2020.

## 9.7 Acknowledgements

This work has been carried out by project SIARA and X2Rail-4 funded by the European Union with the European Regional development fund, the French state and Hauts de France Regional council and SNCF.

The project X2Rail-4 has received funding from the Shift2Rail Joint Undertaking (JU) under grant agreement No. 881806. The JU receives support from the European Union's Horizon 2020 research and innovation programme and the Shift2Rail JU members other than the Union.

Disclaimer: This dissemination of results reflects only the authors' view and the Shift2Rail Joint Undertaking is not responsible for any use that may be made of the information it contains.



## 9.8 Authors



Dr. **Mohammed Kalaagi** is a research fellow at Institut de Recherche Technologique RAIENIUM, branch of Villeneuve d'ascq in France since 2021. He received his Masters degree in Microwaves from the Lebanese University- Faculty of Science and Technology and a Ph.D degree in Electromagnetics from the University of Lille 1, France in 2016 and 2021 respectively. He was a research engineer in 2017 at IFSTTAR and worked on project SCOOP@F for vehicle safety communication systems. His research interests include design and modelling of metasurfaces and antennas for radar, communication systems and EM energy harvesting applications in the railway infrastructure. He has been author and co-author of applied physics journals and many high class IEEE conference papers. He is currently involved in X2Rail-4 project.

E-Mail: mohammad.kalaagi@railenium.eu



Dr. **Divitha Seetharamdoo** is a senior researcher at University Gustave Eiffel, campus of Lille in France since 2008. She received Masters degree in High frequency Communication systems from Paris-East university, France and a Ph. D. degree in Telecommunication systems from Rennes I university, France in 2002 and 2006 respectively. From 2006 to 2007, she was a post-doctoral fellow at École Polytechnique Fédéral de Lausanne (EPFL) in Switzerland. She has been a visiting scholar at the Applied Physics group, Vrije Universiteit Brussel (VUB) in Belgium from 2013 to 2015. Her research interests include the modelling and design of electromagnetic metamaterials for EMC, communication systems and radar applications, computational electromagnetics, the theory of characteristic modes, antenna design and integration on complex railway platforms at microwave and millimeter wave frequencies. She has coordinated and participated in several collaborative research and industrial projects. She has been the author and co-author of several journal papers and book chapters. She is a certified Railway expert from CERTIFER and worked on the certification of the Sydney Metro. She is currently involved in X2Rail projects.

E-Mail: [divitha.seetharamdoo@univ-eiffel.fr](mailto:divitha.seetharamdoo@univ-eiffel.fr)



# 10 Ontology-based Conceptual Model Development for the Railway Domain: A Maintenance Case Study

*Christian Rahmig, DLR, Institute of Transportation Systems, Braunschweig, Germany*

*Sana Debbech, IRT Railenium, Valenciennes, France*

*Itxaro Errandonea, CEIT, Donostia/San Sebastián, Spain*

*Saïoa Arrizabalaga, CEIT, Donostia/San Sebastián, Spain*

## 10.1 Introduction

The railway sector is currently acting in a fragmented way and in silos corresponding most often to physical or functional subsystems or use cases, and the different owners/managers of the overall infrastructure at regional/national level, without global extensive view or full control of the global system involved by rail operations.

A number of digital models however do exist, for different subsystems, and by different stakeholders (railway company's managers, railway manufacturing industry, national policy makers). They are generally not communicating among each other: then, there is currently no global view, no possibility of assessing the effect of design changes of one subsystem on the other interacting subsystems, and more generally, on the overall system operation performance.

Furthermore, the development of new systems involving various stakeholders (railways/industry/engineering) is currently based on non-formal requirements coming from Railway Infrastructure Managers (IM) or Railway Undertakings (RU), rather than on a verified performance of a component/subsystem into the whole system, before tests are carried out in situ at the very end of the development phase. This lack of global performance and formal verification at different stages of the design can possibly entail costly redesigns if the required system performance is not met. With the aim to avoid design errors and to have a shared knowledge view between stakeholders, there is a need to establish conceptual and semantic clarifications of the railway concepts.

This paper is organized as follows: Subsection 10.1.1 describes the SIA project motivations and the need for a common data model for railway infrastructure maintenance. Subsection 10.1.2 summarizes the data modelling ecosystem addressed by the LinX4Rail projects. Section 10.2 provides an overview about the Conceptual Data Model (CDM) approach for the railway domain and resulting modelling requirements. Then, Section 10.3 introduces the usefulness of ontologies, their semantic expressiveness and the proposed process to satisfy digital continuity between models. Section 4 presents the maintenance case study to evaluate and enhance the CDM. Finally, section 5 concludes the paper and proposes some perspectives for ongoing work.

### 10.1.1 Use case description, current architecture and problems

There are several strategies for carrying out railway infrastructure maintenance. From the most basic corrective strategy, to more advanced ones like predictive or even prescriptive maintenance activities, it is necessary to deal with different sources of information when taking decisions about what type of maintenance actuation needs to be done and when [1]. First of

all, information regarding the infrastructure itself and the assets to be maintained need to be gathered; this is currently managed from simple excel files to dedicated software tools or even a Geographical Information System (GIS) software. Second, information regarding the status of the assets can come from asset-specific monitoring and diagnostic systems (e.g. geometric measurement and auscultation of Railway Tracks and Overhead Contact Lines (Catenary)), or from visual inspection activities carried out by maintenance operators that may fill in predefined forms that may be (or not) integrated into a dedicated software. Finally, information regarding the management of maintenance activities themselves is necessary (type of activities, procedures, scheduling, resources availability, costs...) that is typically managed in enterprise-oriented software like Enterprise Resource Planning (ERP) or more maintenance-specific software like Computerized Maintenance Management System (CMMS). Figure 10-1 shows the general ecosystem of devices and systems involved in railway infrastructure maintenance.

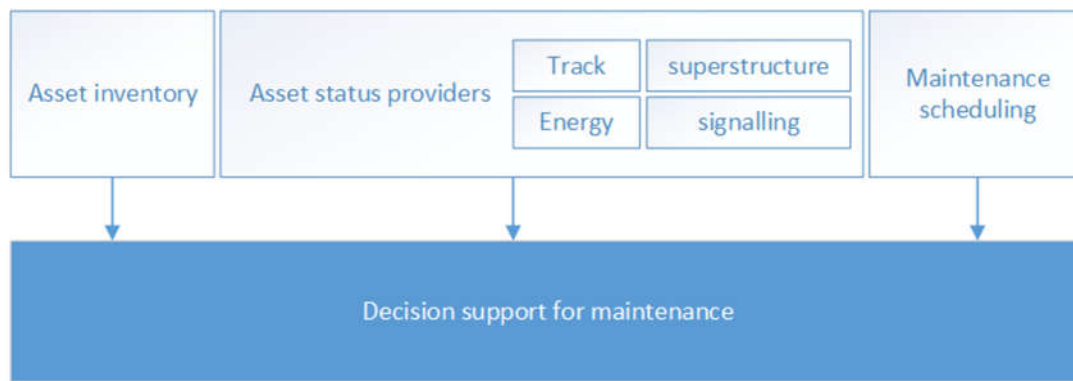

Figure 10-1: Ecosystem of devices and systems involved in railway infrastructure maintenance decision support

The main issue from the data sharing point of view is that there are no standard interfaces between the different information silos, there are no standard APIs (Application Protocol Interface), not all the systems provide features to import/export data, and when they do, the predominant mechanism is proprietary format file-based. This is particularly applicable to the inspection (auscultation) devices for the track and catenary, where each diagnostic device provider extracts information in files with different formats.

This lack of interoperability between devices and software systems is a big barrier that could be avoided if common data models would be used by different providers when developing their devices and systems, in order to be able to exchange data and enable integration of the different silos of information.

With the aim of contextualizing the problem and the possible workaround for dealing with the use of a common data model, part of the work carried out in the SIA project [2] is presented as a use case. Four services for infrastructure asset monitoring were developed (wheel, rail, pantograph and catenary) based on a localization system and sensor devices installed on the vehicle (see Figure 10-2).

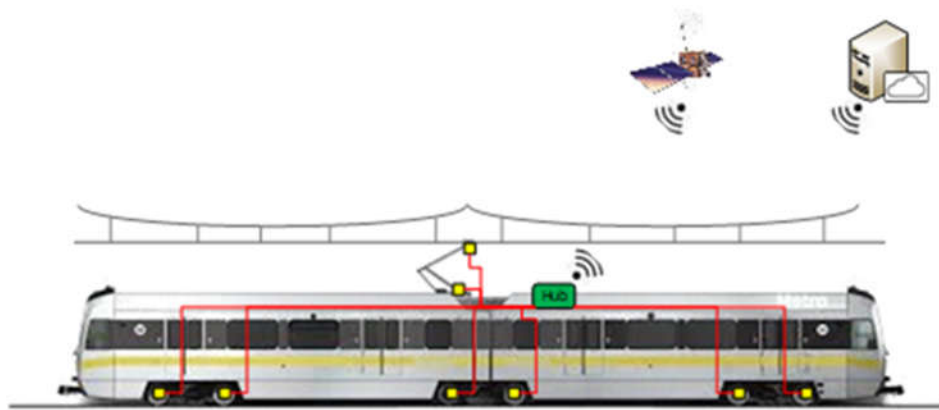

Figure 10-2: SIA system

The positioning system provided the reference information of the location of the damages detected in the infrastructure by SIA\_ABA (for the inspection of the wheel-rail interaction) and SIA\_PANT (for the inspection of the pantograph-catenary interaction) systems (see Figure 10-3). The information collected was transferred to the visualization platform (in the back-office) [3].

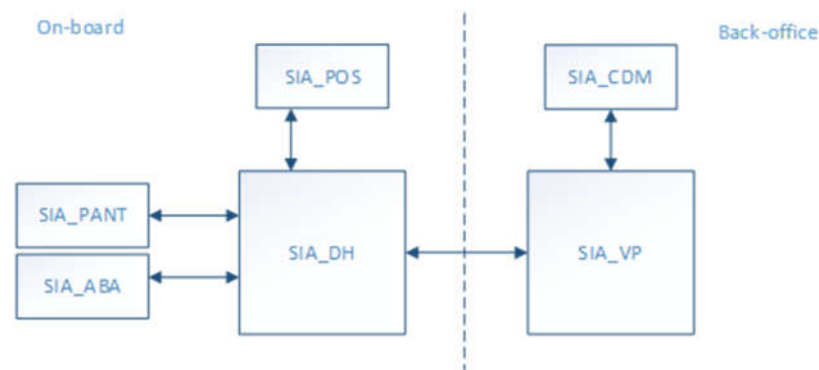

Figure 10-3: SIA sub-systems

Within the SIA project, it was necessary to model the systems that were going to be monitored (both rolling stock and infrastructure). A common data model was desired, but by that time, there were no standard procedures for the process of creating such a common data model, although there were some initiatives focused on modelling efforts in the railway domain.

### 10.1.2 LinX4Rail Modeling efforts

The Shift2Rail project LinX4Rail [4] puts into focus the issue of a missing unified approach towards a Railway System Architecture and a joint Common Data Model including a common railway data dictionary. The project started in December 2019 and will conclude in November 2022. Together with its parallel project LinX4Rail-2, it brings together all modelling and system requirements from the various Shift2Rail projects in order to set up a unified solution agnostic towards project specific aspects and agnostic towards use cases. In order to fulfill this objective, LinX4Rail follows a “system of systems” approach.

The “System of systems” approach and the S2R-CDM are not meant to model the whole railway system. Its objective is to define a unified conceptual structure and data model representing the components of the railway system, and the kind of information they exchange

during their operation, identifying the relations between them and providing a common language and data dictionary to identify them and describe them.

The LinX4Rail data modelling ecosystem includes two dimensions: The Common Data Model (CDM) is based on UML class diagram representation of data. Its objectives, concept and requirements are described in the following section. The second dimension is based on “ontologies”, which are intended to connect different data models via logical relationships described in graphs. The ontology concept is presented in section 10-4.

## 10.2 Common Data Model

Considering the fact that different railway operation and maintenance use cases have different requirements and, therefore, result in different use case specific data models, the CDM shall build a common core and act as universal “glue” between these different models. In particular, CDM is not defined as a new standard model, but as a consistent federation of railway system data models, based on existing ones coming from various initiatives and projects, e.g. RailTopoModel, railML, EULYNX and IFC Rail. The aim of this approach is to include active modelling initiatives to avoid competition and overlapping of models. The result is a collaborative railway system architecture, which meets the requirements of the existing use cases and which allows for the creation of new business cases.

The consistent federation of railway system data models forming the CDM ecosystem is visualized in Figure 10-4.

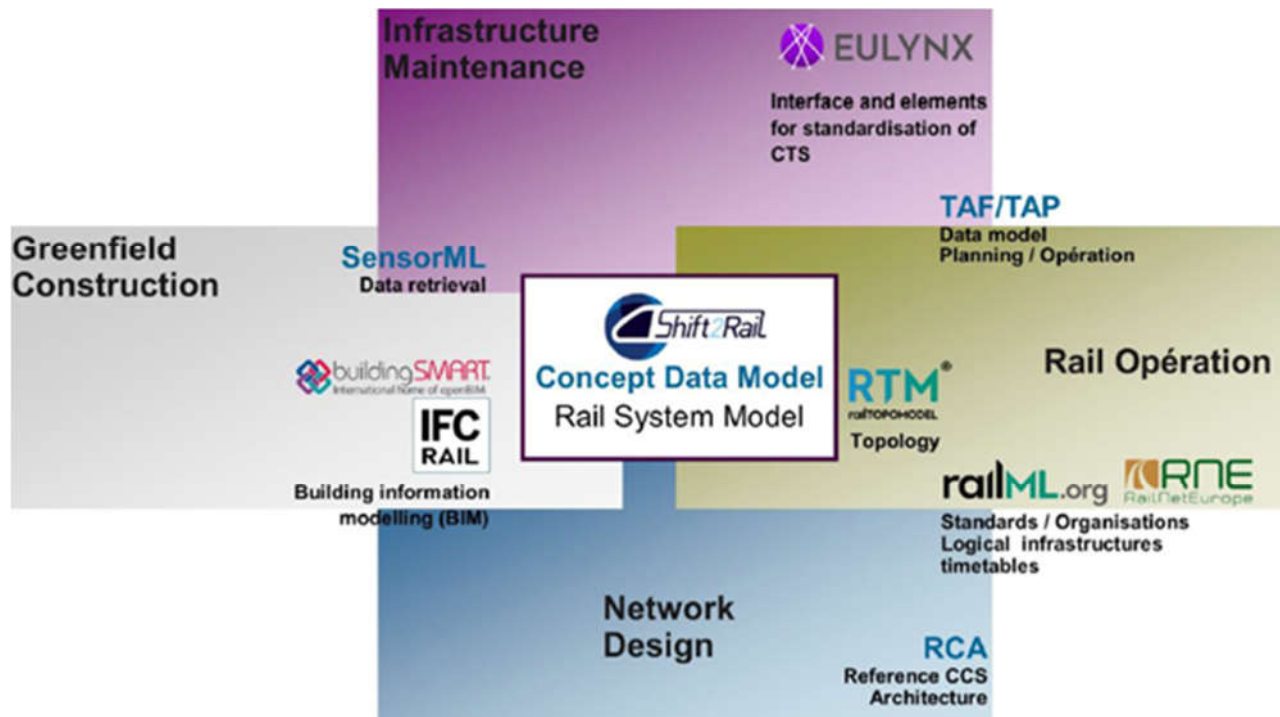

Figure 10-4: CDM ecosystem

The roots of the CDM can be found in the Shift2Rail Lighthouse Project IN2Rail. One main focus of this project was on Intelligent Mobility Management including research on automated, interoperable and inter-connected advanced traffic management systems (TMS). In that context, a standardized integrated information and communication environment has been set

up as a so-called “**Integration Layer**” to provide standard interfaces to external systems outside TMS/dispatching on a plug-and-play basis (see [5]). The need for integration of data from different sources and various domains in combination with the need for a standardized data exchange for TMS purposes resulted in the foundation of a Canonical Data Model (CDM). In that context, the CDM has been defined as a structured breakdown of the various entities in a railway system focusing on real world objects and their relations instead of specific usages or services (see [6]). On the basis of the CDM, the Integration Layer will be able to adapt to different TMS external systems and interfaces without running into compatibility problems of data models and exchange formats. Consequently, data exchange formats following an application independent approach like the XML-based railML will be best suited to CDM objectives.

In order to meet the objectives defined by the LinX4Rail project, CDM needs to fulfil a number of requirements. These requirements are described in detail in [7] and are summarized in the following list:

- Consistent references: every element reference needs to have a valid destination within CDM
- Consistent base types: CDM contains a limited set of data base types
- Scalability: Conversion between domain-specific models via CDM needs to be automated
- Automated versioning of the generated CDM due to independent highly-frequent changes in domain-specific models
- Linking: CDM UML must be linked with use cases
- Reusability: CDM ecosystem must allow for conversions into PSM
- Source model tracing: CDM must integrate tracking information from the source model
- Implementation: CDM shall be available as UML in Enterprise Architect
- Changelog: CDM must allow for annotations of reasons for model modification decisions
- Ontologies: CDM ecosystem shall preserve modelling decisions for long-term solution based on ontologies.

Based on the requirements, the CDM modelling framework is structured as a two-step process: at first, the comparison of the current CDM with the use cases is done manually. Resulting decisions are automatically implemented in the second step. This process is iterative: the decision step is applied until the resulting CDM fulfils the use cases. Its results are documented in a formal representation. This decision implementation script is applied to any source model to be considered within the CDM ecosystem. Thus, a new version of the CDM is being



generated. The decision script ensures data model consistency by applying validation checks. The project milestone report [7] provides further details on this process.

Model Driven Engineering covers the different phases of the system/software development cycle based on a framework of model transformations [8]. In order to improve practices of system development, the OMG (Object Management Group) offered the paradigm of Model-Driven Architecture (MDA), which is based on the separation of business logic from implementation logic. This architecture defines four main types of models: **CIM** (Computation Independent Model) represents the highest level of abstraction and describes the system requirements and the environment in which it will operate. **PIM** (Platform Independent Model) describes the system regardless of the target platform on which it will run. **PDM** (Platform Description Mode) is the model that describes the execution platform. Then, **PSM** (Platform Specific Model) is the more refined model of the MDA, and it is used to generate the code that will be executed on a specific platform. From this perspective, the proposed methodology is based on the model transformation from the conceptual level (PIM) using UML models to the knowledge level (CIM) using ontologies. This transformation facilitates the semantic alignment and federation between heterogeneous source models.

## 10.3 Ontologies and Semantic interoperability

### 10.3.1 Semantic heterogeneity between models

The multiplicity of knowledge sources may induce ambiguities due to several interpretations. In the context of data exchange and management, a common terminology with non-ambiguous semantics is crucial in order to ensure an efficient communication between experts and digital models [9]. Furthermore, a shared view of knowledge enhances the decision-making process and unifies the understandability and the interpretation of domain concepts. From this perspective, ontologies have powerful capabilities to deal with this semantic heterogeneity and to clarify the definition of concepts [10]. This knowledge representation formalism is widely used in industrial domains with the aim to reach semantic interoperability and to provide a common vocabulary between stakeholders [11]. The intended semantic interoperability is the key feature of an efficient knowledge management and integration of interrelated information. The semantic interoperability ensures that information exchange and knowledge alignment make a unique sense regarding stakeholders' interpretations. In other words, the knowledge alignment in a specific domain requires a high level of semantic, syntactic, and structural interoperability. Figure 10-5 shows the complementarity between these aspects, ranging formalisms from less formal to highly expressive with formal semantics.

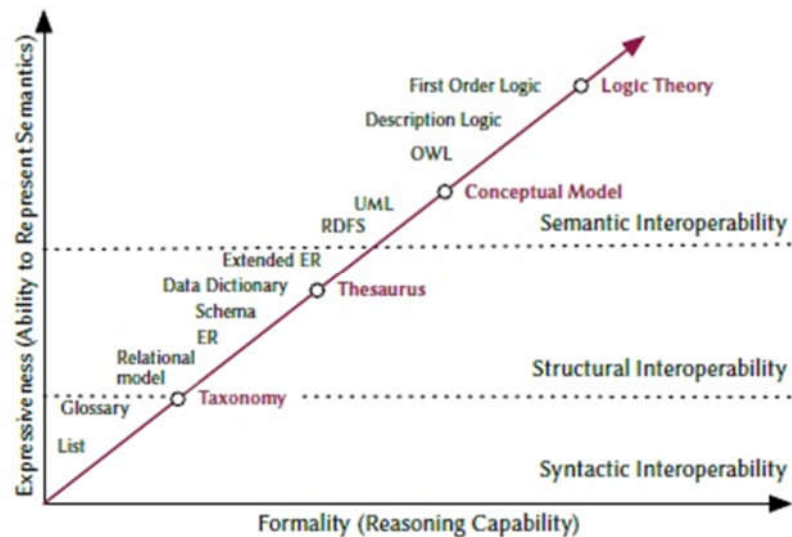

Figure 10-5: The ontology spectrum [12]

### 10.3.2 Ontologies for knowledge alignment

Ontologies originate from philosophy and are the key elements of knowledge representation. The reference definition of ontologies that is widely used in the Knowledge Engineering community is Gruber's definition:

"An ontology is an explicit specification of a conceptualisation" [13].

Otherwise, an explicit specification refers to a formal description of a set of domain concepts, types, properties, and relations between them. An ontology should capture consensual knowledge of a specific domain and allow its semantic clarification through a common vocabulary. In a multidisciplinary context, ontologies have an added value since they define a shared and unambiguous view between stakeholders. Ontology is widely used in the railway domain, namely to facilitate data exchange in the InteGrail project [14] and to ensure interoperability between models in the Ontorail project [15]. Furthermore, ontology development in the railway sector is focused on the formalization of requirements specification of ERTMS [16].

With the aim to overcome this ambiguity and to guarantee a consistent shared understanding of the meaning of information, the use of upper ontologies is crucial [17]. Indeed, upper ontologies represent the abstract level of ontologies typology. They provide foundational concepts and relations between them that are independent of domains such as Situation, Event, Object, Action, etc.

Also, upper ontologies allow to create a "semantic bridge" between multidisciplinary actors. As recommended by knowledge engineering standards, reusing well-established ontologies in the development of a domain ontology allows one to take advantage of the semantic richness of the relevant concepts and logic already built into the reused ontology. The knowledge alignment using upper ontologies is based on a knowledge engineering process, which is composed of 5 main steps. This process ranges from the knowledge extraction step to the conceptual modelling in UML and the matching with foundational concepts, the implementation in OWL (Web Ontology Language) and its validation using logical reasoners.

Therefore, ontologies and conceptual models are both useful and complementary to have a semantic and conceptual clarification of knowledge domain. Figure 10-6 represents the proposed process to perform the alignment between models based on a top-level or upper ontology.

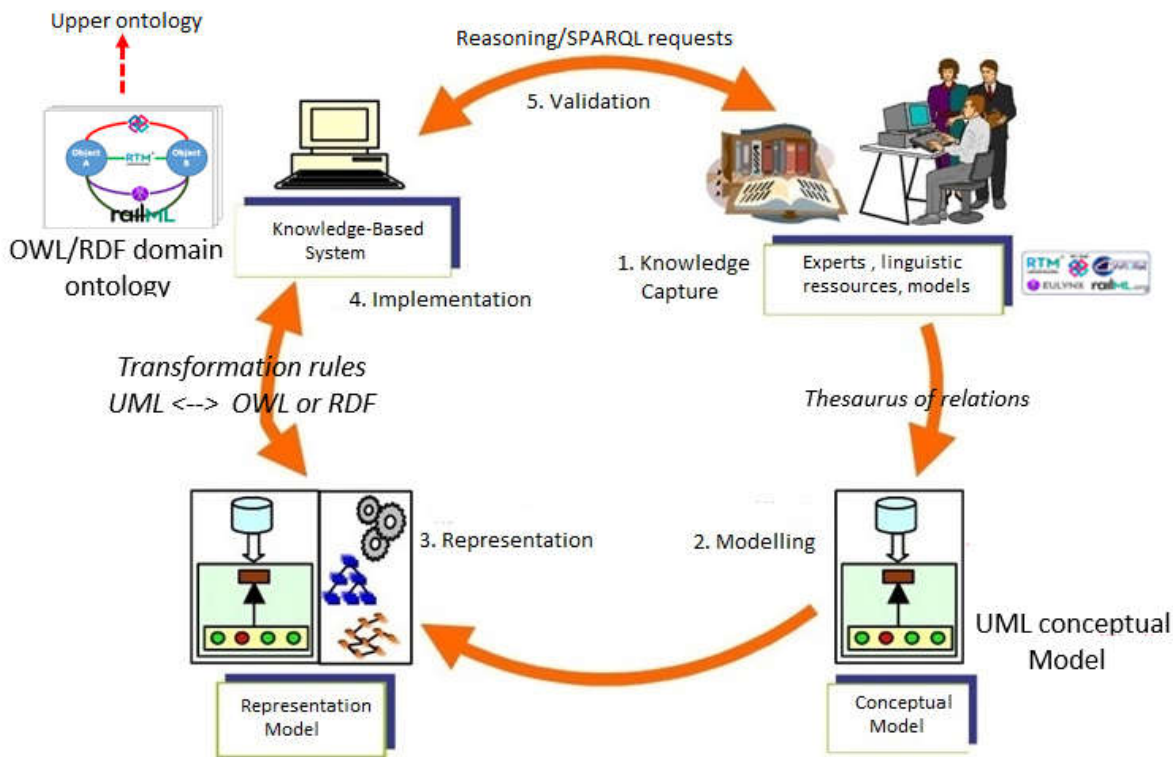

Figure 10-6: Knowledge engineering process for models federation

## 10.4 From theory to application: Maintenance use case

In the SIA project, the requirements of the three sub-systems defined in the project have been defined: Positioning system (SIA\_POS), Catenary health status provider system (SIA\_PANT) and Track health status provider system (SIA\_ABA) [18]. A platform independent model (PIM) has been defined in UML language based on two existing models: RTM/RSM 1.2 (RailTopoModel/Rail System Model) [19] for common packages imported and railML 2.4 and 3.1 [20] for subsystem packages derived (for example, rolling stock and catenary items).

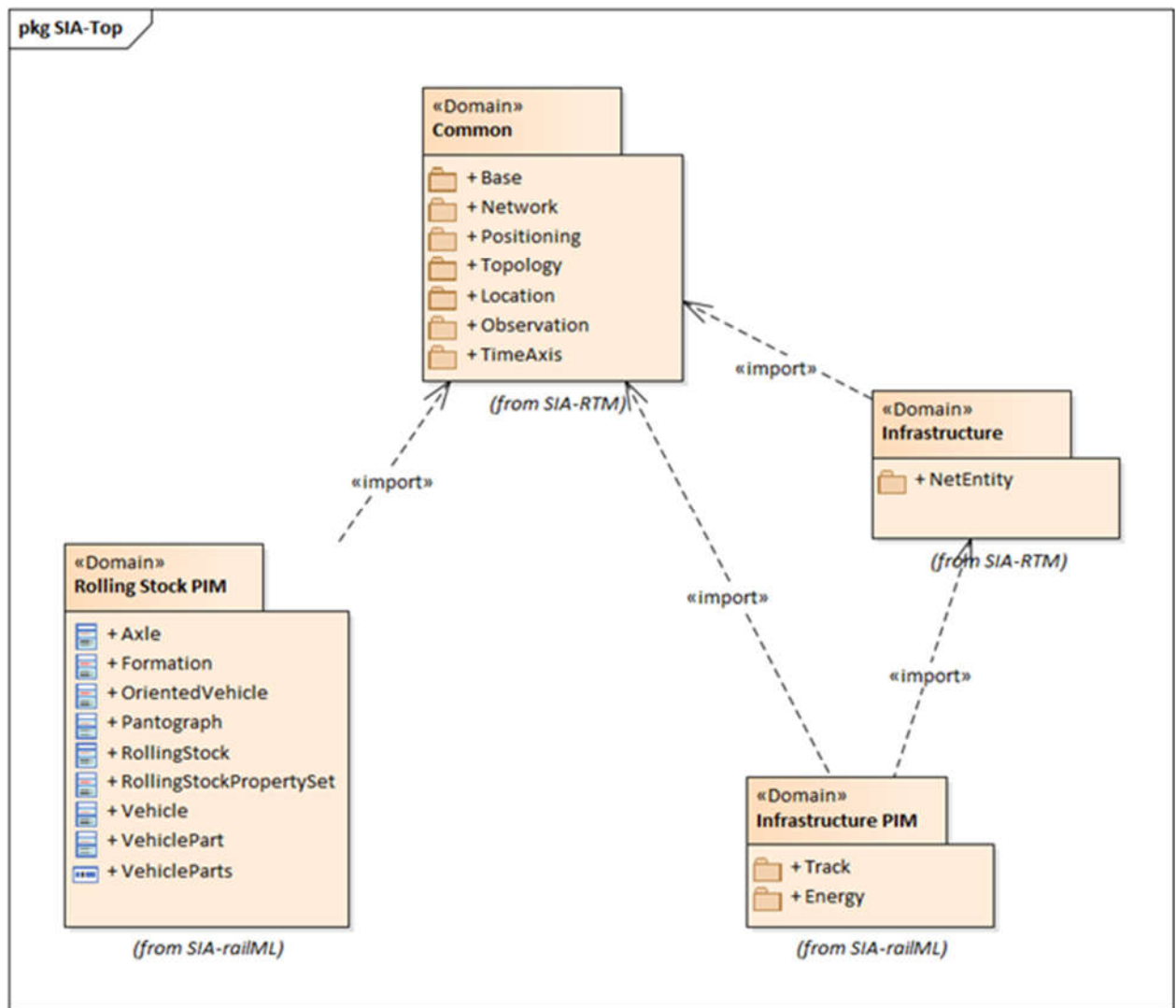

Figure 10-7: SIA PIM model

Figure 10-7 shows the two top packages as subsets of RSM 1.2, and the two bottom packages as subsets of railML. Dependencies are never bi-directional nor circular: following the “Dependency inversion” principle, itself the “D” in “SOLID” principles, abstractions do not depend on details, but details depend on abstractions [21].

This is not an official model, however, it demonstrates that tailoring a model for a definite purpose, using existing domains and entities, is feasible and realistic, provided the models used have been designed for such purpose. Also, it allows to test diverse ways of assembling existing UML models and generating data exchange formats. It provides material for extension of the CDM.

As an extension for the maintenance use case requirements (such as maintenance activities information) further approach has been worked out in LinX4Rail, in order to evolve to a CDM that integrates the maintenance use case, between other use cases, in detail.

The methodology for working in such a model is described in Figure 10-8.

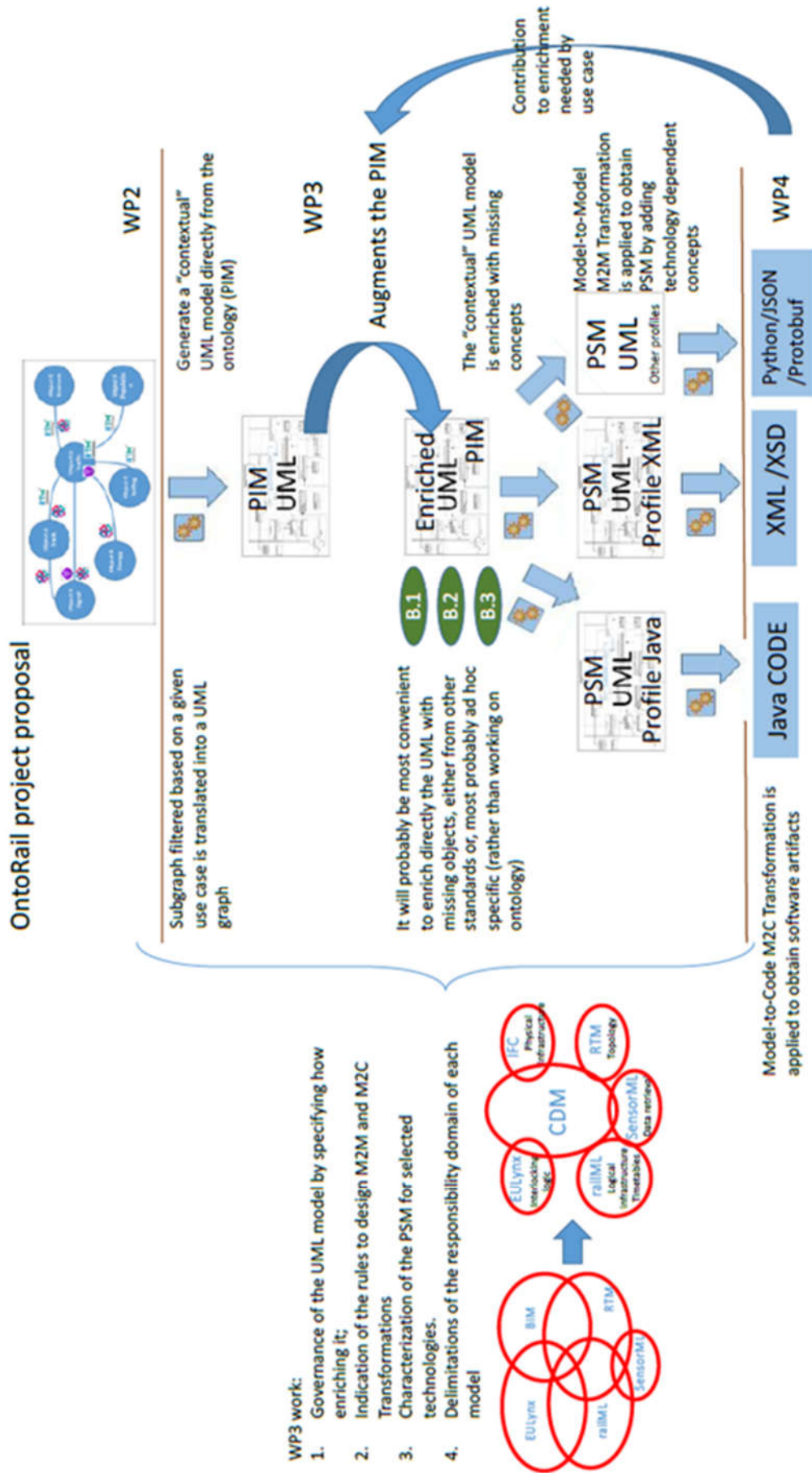

Figure 10-8: LinX4Rail workflow implementation [22]

To identify CDM gaps in the different use cases, the process to follow would be as follows:

1. Identify the requirements of the three sub-systems defined in the project.
2. Starting from data requirement list and preliminary CDM, perform a gap analysis evaluating the domain, entity, attribute and relationship coverage.
3. Identify gaps to extend the CDM.
4. Interact with CDM experts to manage needed CDM extension (e.g., suggesting extension taken from existing source models).

The aim of the work carried out here is clearly to identify possible gaps and then to analyse them and propose new extensions for CDM. This will result in a more complete PSM, thus enabling the development of SW artefacts.

In addition to the requirements defined within the SIA example, the following requirements have been identified for the CDM:

- Maintenance procedures and resource management.
- Inspection data, which could be represented as measurements.

## 10.5 Conclusions and Open Issues

Since 2019, the Linx4Rail project faces the challenge of defining a unified conceptual structure and a common data model that can represent all the different components of railway systems. To this end, the data modelling ecosystem created includes two dimensions: the first one refers to defining a CDM. It is about creating a unified core data model that contains all those requirements that are already defined in pre-existing models. The second dimension makes references to ontologies. Its objective is to create connections between existing domain-specific data models via logical relationships. In this way, the semantic heterogeneity found in the models is addressed in order to facilitate interoperability between them.

The SIA project, like many others, was developed before addressing this challenge. For this reason, the data model used for the exchange of both operation and maintenance information is specific to the system. With the strategy being implemented in Linx4Rail, interoperability between the different systems developed in the rest of the Shift2Rail projects would be strengthened. In addition, the information exchange would be based on a common concept structure.

During the LinX4Rail project, several use cases from other projects in different areas have been analysed. The work done in the analysis of these use cases determines what the requirements of the developed railway systems are. In the SIA project, the focus is on the area of maintenance. In the analysis of the SIA system, several requirements have been identified for each of the developed subsystems, apart from the need to manage procedural information and maintenance resources, such as inspection data management. The analysis performed shows that the strategy maintained in Linx4Rail is applicable to real use cases.

To conclude, there are several future works to be done in this order. Certainly, different use cases will continue to be analysed in order to identify and integrate the different requirements to the CDM. Progress will also continue to be made on interoperability between domain-specific models and the core CDM. Furthermore, Linx4Rail results will be used as a consistent basis for the system pillar ramp up activities. To this end, the participation in initiatives such as EU-Rail is key to integrating this knowledge into the basis of the future systems.

## 10.6 Acknowledgements

The project LinX4Rail has received funding from the Shift2Rail Joint Undertaking (JU) under grant agreement No 826141. The JU receives support from the European Union's Horizon 2020 research and innovation programme and the Shift2Rail JU members other than the Union.

Disclaimer: This dissemination of results reflects only the authors' view and the Shift2Rail Joint Undertaking is not responsible for any use that may be made of the information it contains.



## 10.7 References

- [1] I. Errandonea, S. Beltrán, and S. Arrizabalaga, "Digital Twin for maintenance: A literature review"; *Comput. Ind.*, vol. 123, 2020, doi: 10.1016/j.compind.2020.103316
- [2] SIA Project official website: <https://siaproject.eu/>
- [3] I. Errandonea, J. Goya, U. Alvarado, S. Beltrán, and S. Arrizabalaga, "IoT Approach for Intelligent Data Acquisition for Enabling Digital Twins in the Railway Sector"; in *2021 International Symposium on Computer Science and Intelligent Controls (ISCSIC)*, Nov. 2021, pp. 164–168, doi: 10.1109/ISCSIC54682.2021.00039.
- [4] LinX4Rail project overview; [https://projects.shift2rail.org/s2r\\_ipx\\_n.aspx?p=LINX4RAIL](https://projects.shift2rail.org/s2r_ipx_n.aspx?p=LINX4RAIL); last access: 02.03.2022
- [5] In2Rail: Innovative Intelligent Rail. <http://www.in2rail.eu/>; last access: 20.05.2020
- [6] Karlsson, M. and Wegele, S. (2017): Digitalisation - Toward seamless connectivity; in: *Global Railway Review*, Vol. 23, issue 05.
- [7] LinX4Rail: MS6 report - Preliminary input on CDM for use case developments in WP4; 29.04.2021
- [8] O. Betari, S. Filali, A. Azzaoui, M. A. Boubnad, "Applying a Model Driven Architecture Approach: Transforming CIM to PIM Using UML"; *International Journal of Online and Biomedical Engineering (iJOE)*, Vol. 14, No. 9, 2018.
- [9] Elmhadhbi, L., Mohamed-Hedi Karray, and Bernard A.: *Toward the use of upper-level ontologies for semantically interoperable systems: An emergency management use case. Enterprise Interoperability VIII*. Springer, Cham, 2019. 131-140.

- [10] Debbech, Sana, Simon Collart Dutilleul, and Philippe Bon. An Ontological Approach to Support Dysfunctional Analysis for Railway Systems Design. *J. Univers. Comput. Sci.* 26.5 (2020): 549-582.
- [11] Nilsson, Jacob, and Fredrik Sandin. Semantic interoperability in industry 4.0: Survey of recent developments and outlook. 2018 IEEE 16th international conference on industrial informatics (INDIN). IEEE, 2018.
- [12] L. Obrst. Ontologies for semantically interoperable systems . In: Proceedings of the twelfth international conference on Information and knowledge management - CIKM '03. New York, USA: ACM Press, Nov. 2003, p. 366
- [13] Gruber, T. R. (1993). A translation approach to portable ontology specifications. *Knowledge acquisition*, 5(2):199–220.
- [14] <http://www.integrail.eu/>
- [15] <https://ontorail.org/>
- [16] Hoinaru, O., Mariano, G. et Gransart, C. (2013). Ontology for complex railway systems application to ERTMS/ETCS system. In FM-RAIL-BOK Workshop in SEFM 2013, 11th International Conference on Software Engineering and Formal Methods, page 6p
- [17] Antunes, G., Caetano, A., Bakhshandeh, M., Mayer, R., and Borbinha, J. (2013). Using ontologies to integrate multiple enterprise architecture domains. In International Conference on Business Information Systems, pages 61–72. Springer.
- [18] In2Rail Project Deliverable D9.1: “Asset status representation”; October 2016.
- [19] UIC: RailTopoModel (RTM) version 1.1 release webpage: <https://uic.org/rail-system/railtopomodel>
- [20] railML.org: Official railML website. <https://www.railml.org/en/>;
- [21] SIA Project Deliverable D5.3: “Modified XSD and matching RailTopoModel class diagram”; September 2020
- [22] Linx4Rail Project Deliverable D4.1: “Demonstration indicator and use cases description”; August 2021.

## 10.8 Authors



Dipl.-Ing. **Christian Rahmig** (m) graduated at the University of Technologies in Dresden in the field of Transportation Engineering with focus on Transport Telematics. He joined DLR Institute of Transportation Systems in the year 2009, where he contributed to a lot of national and international projects focusing on multi-sensor data fusion, on-board positioning, digital maps and data models for usage in railway applications. Since 2015, he works as business developer for the Institute, at first for the Railway Department and since 2021 for the Department of Information acquisition and data modelling.

E-Mail: [christian.rahmig@dlr.de](mailto:christian.rahmig@dlr.de)





Dr. -Ing. **Sana Debbech** (f) received the Eng degree from the National School of Computer Science in Tunis in 2015 and the PhD degree in automatics and computer engineering from the Ecole Centrale de Lille in 2019. She is leader of Of'BIM competence center working in fields of Railway ontologies, model-driven engineering, and Building Information Modeling (BIM) at Railenium. She is involved in several French and European projects and has research activities in ontology engineering and MBSE usage for digital continuity in the railway domain. She is a reviewer of scientific publications for several conferences and journal focusing on semantic web and knowledge engineering and she is member of technical WG in the same fields.

E-Mail: sana.debbech@railenium.eu



**Itxaro Errandonea** (f) received her M.Sc. degree in Computer Science at the Faculty of Informatics in San Sebastian (University of the Basque Country) in 2017. Since then, she has been working at Ceit-BRTA in San Sebastian as a research assistant in Information and Communication Technologies (ICTs). His research activity focuses on data analysis and information management. She has participated in research projects studying new methodologies for the digitization, monitoring, and diagnosis of asset health status for the railway sector. She is author of two articles in JCR journals and two international conference papers. She is currently developing her doctoral thesis at the University of Navarra on new methodologies for maintenance using digital twins.

E-Mail: ierrandonea@ceit.es



**Saioa Arrizabalaga** (f) received her M.Sc. degree in Telecommunication Engineering from the Faculty of Engineering in Bilbao (University of the Basque Country) in 2003, and her Ph.D. degree in Engineering from TECNUN in 2009. She is a lecturer at TECNUN (University of Navarra), and a researcher at Ceit-IK4. She is the Head of Data Analytics and Information management Research group and is involved in the participation of European research projects, direction of doctoral theses, scientific and technical publications in national and international journals and conferences

E-Mail: sarrizabalaga@ceit.es

# 11 The KPI-Model – An integrated KPI assessment methodology to estimate the impact of different innovations in the railway sector

Filiz Kurt, DLR, Institute of Transportation Systems, Braunschweig, Germany

Alessa Isberner, DLR, Institute of Transportation Systems, Braunschweig, Germany

Michael Meyer zu Hörste, DLR, Institute of Transportation Systems, Braunschweig, Germany

Jürgen Ernst, Deutsche Bahn AG, München, Germany

Abderrahman Ait Ali, VTI, Stockholm, Sweden

## 11.1 Abstract

The Shift2Rail Joint Undertaking (S2R) has set impact targets for the future rail system. Those targets of the KPIs, calculated by comparing future KPIs in the year 2030 to baseline KPIs as of 2013, are defined in the Shift2Rail Master Plan. These include among others to double the capacity (+100%), half the life cycle costs (LCC) (-50%) and to increase punctuality by improving reliability by 50% [1]. In order to keep track of the realisation of these targets and to measure their degree of fulfilment a quantitative KPI model has been developed. The modelling approach and implementation are discussed in this contribution.

## 11.2 Introduction

As part of the cross-cutting activities of the Shift2Rail Joint Undertaking (S2R), the IMPACT-2 project focuses, inter alia, on the integrated assessment of the impacts of the S2R innovations by developing a Key Performance Indicator (KPI) methodology. Based on the S2R objectives, not only the economic impacts of the S2R innovations but also the socio-economic and modal shift impacts were analyzed within the framework of Work Area 2 of the Project IMPACT-2. As shown in Figure 11-1, three models were created for this purpose: the KPI model (in orange), the Customer Experience Model (in grey) and the Modal Shift Model (in green).

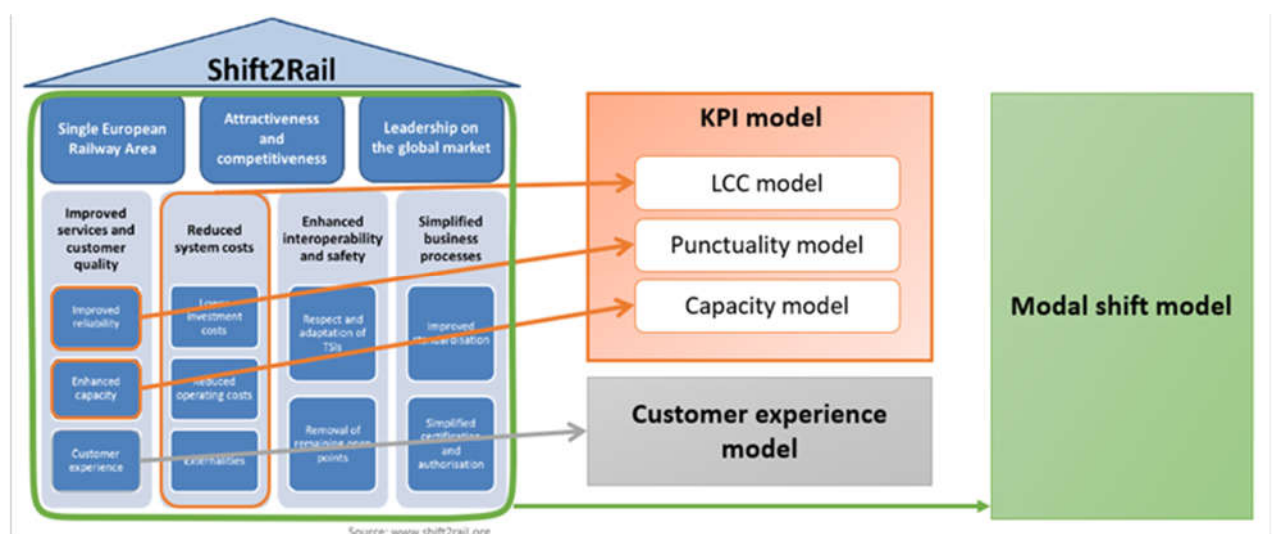

Figure 11-1: Overview of the different IMPACT-2 models of Shift2Rail including the KPI model

The KPI model estimates the impacts of the S2R innovations on the future railway system once the S2R innovations are implemented. The KPIs considered within the KPI model are Life-Cycle-Cost (LCC), Reliability & Punctuality, and Capacity. The targets of the KPIs, calculated by comparing future KPIs (2030) to baseline KPIs (2013), are defined in the Shift2Rail Master Plan [1] as follows:

- doubling Capacity (+100%);
- halving Life-Cycle-Cost (-50%);
- increasing Punctuality by improving reliability by +50%

The KPI Model is a quantitative model organized into three sub-models: LCC Model, Punctuality Model and Capacity Model. It is based on specific generic scenarios called System Platform Demonstrators (SPD), which are structured into four market segments: High Speed, Regional, Urban (metro) and Freight. Besides the KPI Model, the Customer Experience Model specifically identifies areas with high potential for improvement in terms of customer satisfaction. Finally, the Modal Shift Model was developed to reflect the impact of the S2R innovations on modal shift. The focus of this paper is on the KPI model.

## 11.3 Methodology

### 11.3.1 Common Approach

The KPI model developed in IMPACT-2 is based on the general structure of the KPI model, developed in IMPACT-1 [6]. The developed KPI model is based on S2R's five key Innovation Programmes (IPs) encompassing relevant technical and functional technology subsystems as structured in Rolling Stock (IP1), Command, Control and Signaling (IP2), Optimized Infrastructure (IP3), Digital Services (IP4) and Rail Freight (IP5) [7].

The three separated sub-models display the effects of S2R-innovations on the KPIs Life-Cycle Costs (LCC), Reliability & Punctuality (or simply Punctuality in what follows) and Capacity. Thereby the sub-models have been developed separately for passenger transport and for freight transport. For freight, the model is further split into three sub-scenarios (i.e., single wagon train, block train and combined transport train) to better capture the operational differences. Hence, there are in total six sub-models. Similar modelling approaches and algorithmics have been used for all of them. Figure 11-2 demonstrates the common approach of the KPI methodology.

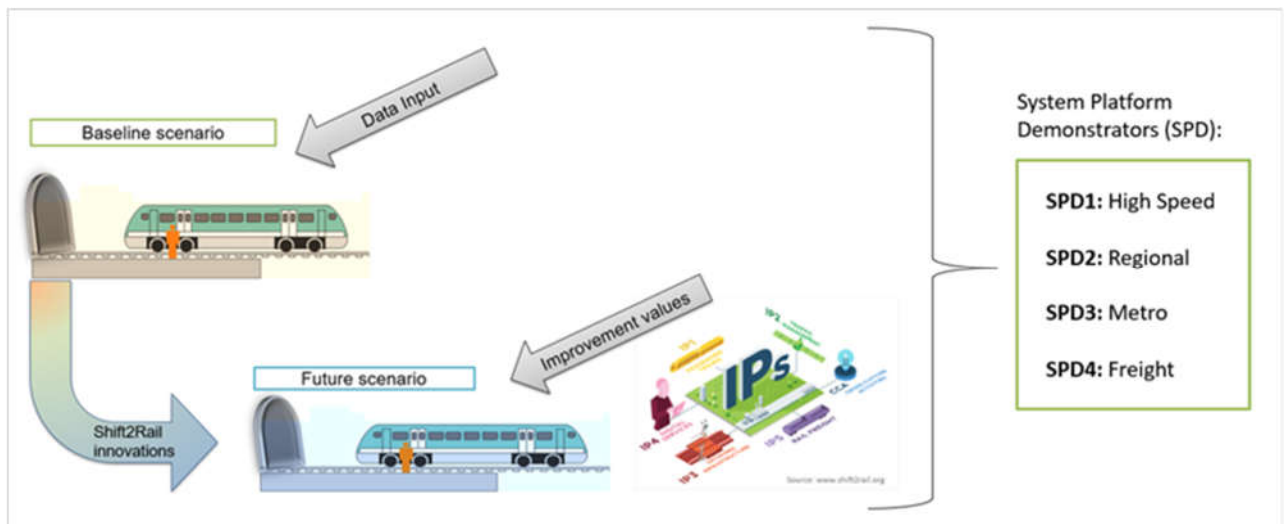

Figure 11-2: Illustration of the adopted methodological approach in the KPI model of IMPACT-2

The KPI model generates in the first step a baseline scenario describing a defined representative scenario for the European railway system. In the second step, the effects of the S2R innovations are analyzed within the IPs by their so-called Technical Demonstrators (TDs) in terms of the expected impacts on the three KPIs. This leads to percentage improvements, hereafter called “improvement values”. The targets are the maximum achievable improvements as a priority for the respective KPI. The improvement values are then fed into the KPI model. Finally, calculating a scenario for a future railway system in which the roll out of all S2R innovations is completed. In the following, the three high-level KPIs are described first for the passenger and then for the freight model.

### 11.3.2 Passenger Specific Model

The methodology for estimating improvements in LCC is based on the assessment of system components existing in the baseline scenario as well as in a modified or improved form in the future Shift2Rail scenario [4]. Figure 11-3 provides an overview of the LCC model structure.

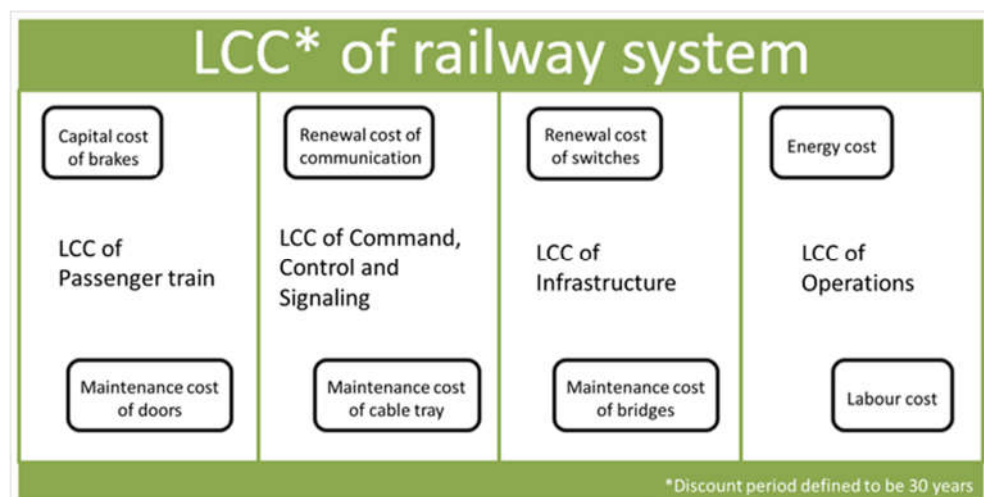

Figure 11-3: Structure of the passenger specific LCC model of Shift2Rail

In the baseline scenario, both the capital costs and the operational costs of various system components were collected and discounted over a period of 30 years. For the future scenario, the TDs in IP1 (Rolling Stock) and in IP3 (Infrastructure) provided specific improvement values on both capital and operational costs resulting from the technological development of the system components. For the innovations of Command, Control and Signaling (CCS), an additional approach was integrated into the LCC model. This approach was necessary as most system components would be replaced or changed in such a way that a cost improvement of the future system could not be assigned directly to each individual component. Several improvements depend on the system effect or aim at transferring functions to other components (e.g., more functions on the train instead of the infrastructure). For this reason, the methodology was extended to allow the estimation of LCC improvements through Command, Control and Signaling innovations by allocating the components of the reference system and the future Shift2Rail to the functions for which they are required [4].

The methodology for assessing capacity improvements is based on peak hours. The Capacity calculation consists of three main parts: First, the track capacity is defined as the number of trains per peak hour per day. Second, Train Capacity is defined as the number of passengers that can potentially be transported per peak hour on a given route. Last, coupling ability is defined as the number of, coupled units per train. Hence, the capacity model is composed of the capacity improvements of the infrastructure, of the trains and of the signaling system [4].

The methodology for assessing punctuality improvements is applicable in cases where the technical innovations provide a higher reliability or a shorter recovery from delays.

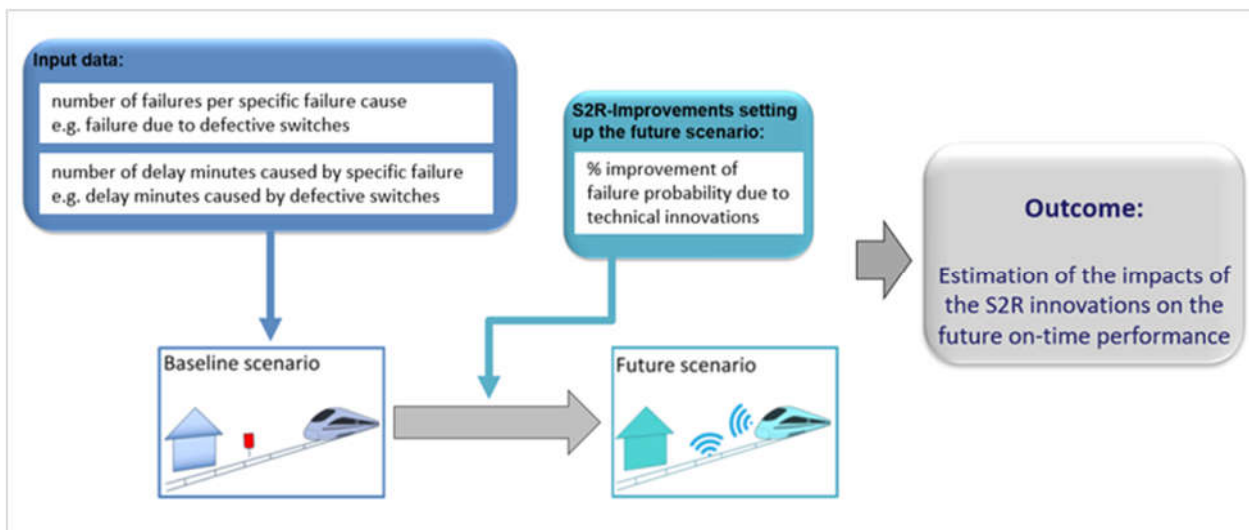

Figure 11-4: Implementation of the methodology into the punctuality model of Shift2Rail

The methodology enables an estimation of the punctuality improvement achieved by the reduction of delay minutes due to a decrease in the number of failures resulting from technical developments. For the baseline scenario, we used input data that was provided by the railway undertakings and infrastructure managers which were actively involved in S2R. In general, the data shows the annual number of failures per specific cause of failure, e.g., the annual number of failures due to defective switches, as well as the number of average delay minutes caused by specific failures, e.g., delay minutes due to defective switches. Based on the input data for the baseline scenario and the improvement values provided by the TDs for the future scenario,

we develop a punctuality model to estimate the impacts of the S2R innovations on the future on-time performance. In addition, special calculation methods were used for parameters that did not fit into the general methodology, i.e., the Train Management System (TMS). In this case, a general performance improvement of the railway system due to an improved handling of delay scenarios has been integrated into the punctuality model [5].

The specific formulas of the KPI model as well as its detailed data are under confidentiality. Consequently, these formulas cannot be further enclosed in this paper.

### 11.3.3 Freight Specific Model

The model for freight transport is more complex than for passenger transport. First of all, three different freight transport categories are considered: single wagon, block, and intermodal transport. Secondly, the total freight transport process from terminal is considered. Figure 11-5 illustrates the freight transport process for the single wagon category.

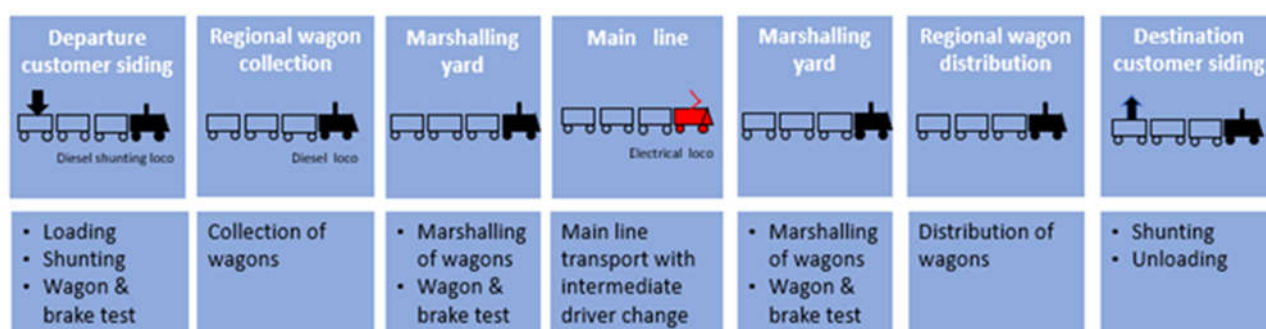

Figure 11-5: Illustration of the freight transport process for single wagon category

The consequence for the LCC- and punctuality model is that beside trains, infrastructure and CCS, additional assets are considered such as terminals and yards. Furthermore, the trains are split into locomotives and wagons since they are decoupled in terminals and yards. Due to the complex process, operational delays and costs play an important role.

It must be considered that Shift2Rail innovations in the freight transport not only have an impact on the assets itself but also on the freight process time. Due to the digitalisation of the freight process including automatic coupling, the process time is significantly reduced. This has a direct impact on the utilisation of the locomotives and wagons (increased yearly km). Hence, the process time has to be calculated in a separate model. Therefore, LCC-reduction is possible although the capital costs of the locomotives and wagons increase.

The capacity model considers two different freight innovations:

- Longer freight trains and coupled trains
- Wagons with increased load per train length

Both innovations also reduce the LCC per ton since more load or containers can be transported with one train.

The last difference to the passenger model is energy consumption and costs. They are influenced by different innovations:

- Improved wagon aerodynamics
- Increased speed
- Connected driver assistant system

Therefore, special energy simulations must be carried out to determine the changes in energy consumption.

## 11.4 Results

The KPI model was developed using Microsoft spreadsheet software Excel. Through the use of Microsoft Excel, it was possible to collect all the information in one file, keeping the input data, general information, calculations and results on separate sheets [4]. It had the additional advantage that all companies in WP4 had a license and the necessary skills to work with the program. Figure 11-6 shows the elements of the KPI Model in Excel.

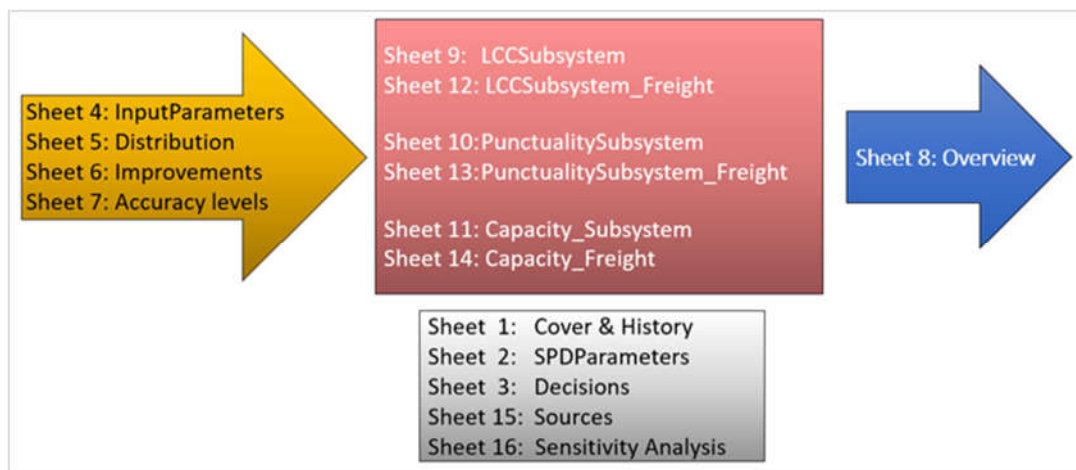

Figure 11-6: Elements of the KPI Excel Model in Shift2Rail

The KPI Model is made up of several sheets feeding into each other. Information on the input parameters for the respective SPDs are entered in the input sheets (in yellow in Figure 11-6). The input information is structured in four input sheets as follows [4]:

- Input Parameters: In this sheet, data is collected to describe the baseline scenario for all four SPDs.
- Distribution: In this sheet, a percentage share of total values is determined for innovations where cost, capacity or punctuality data cannot be captured at the level of detail at which the individual TDs work, e.g., the costs or weights of individual train components are often not available for each component, but only for the train as a whole.
- Improvements: The percentage improvement values provided by the TDs are collected in this sheet.

- 
- Accuracy levels: This is understood as the level of precision under which the TDs have delivered their improvement values.

With the input data, the KPI model creates in a second step the six individual sub-models (in red in Figure 11-6). These Model sheets and its calculations are as follows [4]:

- LCC model related to passenger railway service
- LCC model related to freight railway service
- Capacity related to passenger railway service
- Capacity related to freight railway service
- Punctuality related to passenger railway service
- Punctuality related to freight railway service



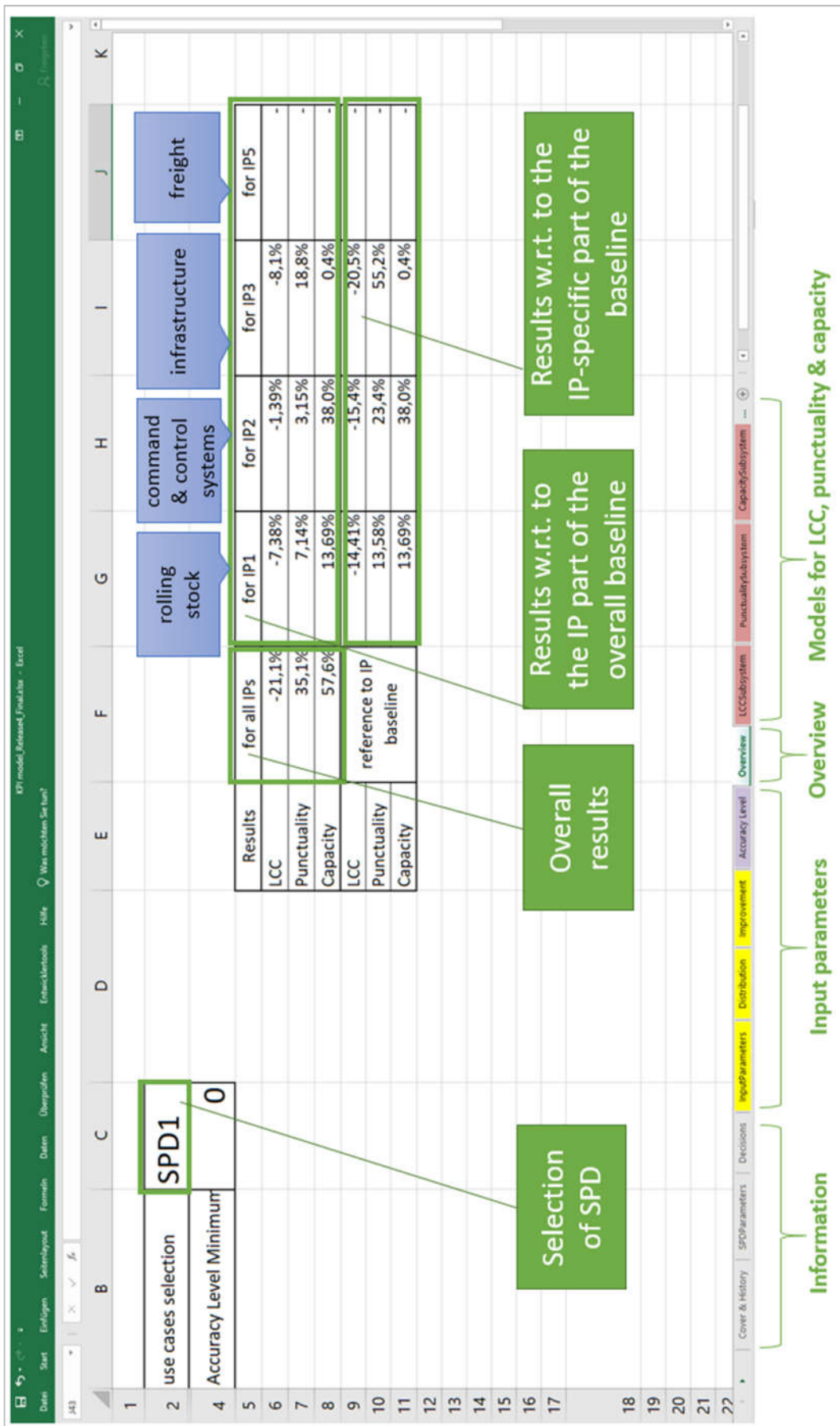

Figure 11-7: Internal structure of the presentation of the assessment results in the KPI Model of Shift2Rail

In the Model sheets, the baseline scenario as well as the future scenarios including the technical innovations are calculated.

For a better summary, the results of the KPI assessment are shown in the result-sheet named "Overview" (in blue in Figure 11-6). Otherwise, there are further administrative or informative sheets (in grey in Figure 11-6) that supply information on the cover and history, explanations, decisions, sources and SPD parameters. Finally, the results of the integrated KPI assessment are displayed in the "Overview" sheet, see Figure 11-7.

On the Overview sheet, it is possible with the help of a drop-down list to select the required SPD. After selecting the respective SPD, the spreadsheet calculates the results of the S2R innovations on the respective high-level KPIs LCC, Punctuality and Capacity. Within this spreadsheet the improvements to the KPIs for the overall results are calculated, meaning when all S2R innovations have been implemented. Further, the spreadsheet provides the results with regards to the IP part of the overall baseline. And finally, the results in relation to the IP-specific part of the baseline are calculated in the model. The impacts of the IPs' technologies are measured separately in this case. As shown, IP1, IP2, IP3 and IP5 are included in the KPI model. Nevertheless, IP4 is considered within the customer experience model, which is mainly about removing obstacles for passengers, thus estimating innovation's potential to improve the customer experience.

## 11.5 Discussion and conclusion

With the described approach, a powerful tool for the impact estimation of the technical developments in the Shift2Rail project has been developed. Given the way the model is structured, it is possible to adapt it to other comprehensive assessments in the railway system. When the necessary data is available, the parameters used in the input sheets can be applied to other use cases. The general calculations, that are used for the three high-level KPIs in the six model sheets, are written in such a way that they calculate the results for any changes in the input sheets. There are, however, a number of special calculatory approaches that are included as described in chapter 2.2 and 2.3. These are necessary due to the high complexity of the railway system. This does, however, have the effect that these calculations cannot easily be transferred to other use cases as they are specifically designed for the project requirements of Shift2Rail.

## 11.6 References

- [1] Shift2Rail Joint Undertaking, "Shift2Rail Master Plan", 14 November 2019. [Online]. Available: <https://shift2rail.org/wp-content/uploads/2020/09/MAAP-Part-A-and-B.pdf>. [Accessed 15 February 2022].
- [2] IMPACT-1 – D4.2 "Subsystem structure and Sublevel KPIs" – 2018, Vol. 1
- [3] Platform of Rail Infrastructure Managers in Europe, "About PRIME: Description", 1995-2022. [Online]. Available: [https://webgate.ec.europa.eu/multisite/primeinfrastructure/about-prime/description\\_en](https://webgate.ec.europa.eu/multisite/primeinfrastructure/about-prime/description_en). [Accessed 15 February 2022].
- [4] IMPACT-1 – D4.3 "Reviewed quantitative KPI model" – 2018, Vol. 1

- [5] Kurt, Filiz und Hainz, Svenja und Meyer zu Hörste, Michael und Brinkmann, Florian (2021) "Impact assessment method to forecast high speed railways punctuality due to technology evolution". 1st International Workshop on High-Speed Rail Socioeconomic Impact, 14.-15. Sep. 2021, Online.
- [6] IMPACT-1 – D4.1 "Reference Scenario" – 2018, Vol. 1
- [7] Shift2Rail Joint Undertaking, "Shift2Rail Factsheet 2018", April 2018. [Online]. Available: [https://shift2rail.org/wp-content/uploads/2018/05/S2R\\_Factsheet\\_DEF.pdf](https://shift2rail.org/wp-content/uploads/2018/05/S2R_Factsheet_DEF.pdf). [Accessed 05 January 2022].

## 11.7 Acknowledgements

The project IMPACT-2 has received funding from the Shift2Rail Joint Undertaking (JU) under grant agreement No 777513. The JU receives support from the European Union's Horizon 2020 research and innovation programme and the Shift2Rail JU members other than the Union.

Disclaimer: This dissemination of results reflects only the authors' view and the Shift2Rail Joint Undertaking is not responsible for any use that may be made of the information it contains.



## 11.8 Authors



**Filiz Kurt** M.A., is a Research Scientist working in the Department Design and Evaluation of Mobility Solutions at the Institute of Transportation Systems of the German Aerospace Center (DLR) in Germany. As part of the European Joint Undertaking Shift2Rail (S2R) she is working in the IMPACT 2 project of the Cross-Cutting Activities on the development of an integrated KPI methodology to analyze and evaluate the impact of different S2R railway technologies on the overall railway transport system, both for passenger and freight transport, using the KPIs life cycle costs, punctuality and capacity.

E-Mail: [filiz.kurt@dlr.de](mailto:filiz.kurt@dlr.de)



**Alessa Isberner** is scientific staff at the Institute of Transportation Systems of the German Aerospace Center since 2018. Her focus is on the design and impact assessment of new transportation technologies and innovative mobility concepts. She works on assessment in the railway system with microscopic simulation as well as key performance indicator-based methodology.

E-Mail: [alessa.isberner@dlr.de](mailto:alessa.isberner@dlr.de)



Dr.-Ing. **Michael Meyer zu Hörste** holds a PHD in mechanical engineering from the technical University of Braunschweig. He has joined DLR Institute of Transportation Systems in 2001 bringing already 6 years of railway research experience with him. He is expert in railway operations, command, control and signalling systems, especially ERTMS/ETCS as well as train localisation. Currently he is working the business development of the DLR Institute of Transportation Systems He was a major contributor in building the DLRs ETCS test laboratory RailSiTe®. He is chairman of the ERTMS Reference Labs Association since 2012. He is fellow of the Institution of Railway Signalling Engineers (FIRSE) since 2012. He is member of the Shift2Rail and EU Rail governing boards as well as the coordinator in the DLR for Shift2Rail and Europe's Rail.

Michael.MeyerzuHoerste@dlr.de



Dr.-Ing. **Jürgen Ernst** is working as a senior project manager within Deutsche Bahn. He has a doctor in electrical engineering, more than 25 years industrial experience in innovative railway technology. For several years he has led interdisciplinary teams responsible for carrying out technical projects concerning the whole railway system. Since 2015 he takes part in several Shift2Rail projects. Within the project IMPACT-2 he is responsible for the KPI assessment for freight.

E-Mail: juergen.ernst@deutschebahn.com



Dr. **Abderrahman Ait Ali** is a researcher at the Swedish National Road and Transport Research Institute (VTI). His research focuses on transport economics. He is also a post-doctoral researcher at Linköping University working with railway and public transport research. As part of S2R, he is working in the IMPACT-2 project on the review of the KPI model with focus on IP3 relating to innovations in railway infrastructure.

E-Mail: abderrahman.ait.ali@vti.se



## **12 Gaining accurate input data for a comprehensive assessment of the railway system**

*Alessa Isberner, DLR, Institute of Transportation Systems, Braunschweig, Germany*

*Svenja Hainz, DLR, Corporate Development, Brussels, Belgium*

*Ida Kristofferson, VTI, Stockholm, Sweden*

*Jürgen Ernst, Deutsche Bahn AG, Munich, Germany*

*Chengxi Liu, VTI, Stockholm, Sweden*

### **12.1 Introduction and Aim / Background**

In order to fulfil the vision of rail being the backbone of carbon free mobility in the future [1], a modernisation of the European railway system is needed. In the Shift2Rail initiative the European railway research community is taking on the task to develop innovations that enable the European railway system to be the “most sustainable, cost-efficient, high-performing, time-driven, digital and competitive customer-centred” transport mode and thus to enable a modal shift to rail [2]. Key targets of halving life-cycle-costs, doubling capacity and improving punctuality by 50% as well as increasing customer satisfaction [3] are pursued through the innovations developed in Shift2Rail. Different model structures for estimating improvements in the named key targets and finally in the resolving change of modal share has been developed by the IMPACT-2 project [4] [5] [6]. All three models are based on artificial scenarios that should reflect a railway system that theoretically might be found somewhere in Europe. To create such scenarios a tremendous amount of data is needed from railway undertakings and infrastructure managers across Europe. Within the IMPACT-2 project, researchers took on the challenge to collect such data and align them to create common scenarios to evaluate the broad range of innovations developed in Shift2Rail. Through this process, several issues were faced from identifying subsidies included in some national cost data to different definitions of indicators with the same name in different companies up to various operational practices across Europe. In this paper, some of these challenges will be addressed and described as well as how the project handled them.

### **12.2 Input data definition for railway assessment**

To make data from different sources comparable and use it within assessment models for the railway system, several aspects have been considered in the IMPACT-2 project. Common definitions, aggregation level of data items as well as measurement techniques are vital. This provides a challenge when the data sources are within the same country and even more so when collecting railway data across Europe [7].

#### **12.2.1 Special challenges in the European railway sector**

Consequently, various challenges have to be faced to gain accurate input data for a comprehensive assessment of the railway system. Historically, systems often still end at the

national borders. As can be seen in Figure 12-1, this leads to various differences between the countries in Europe.

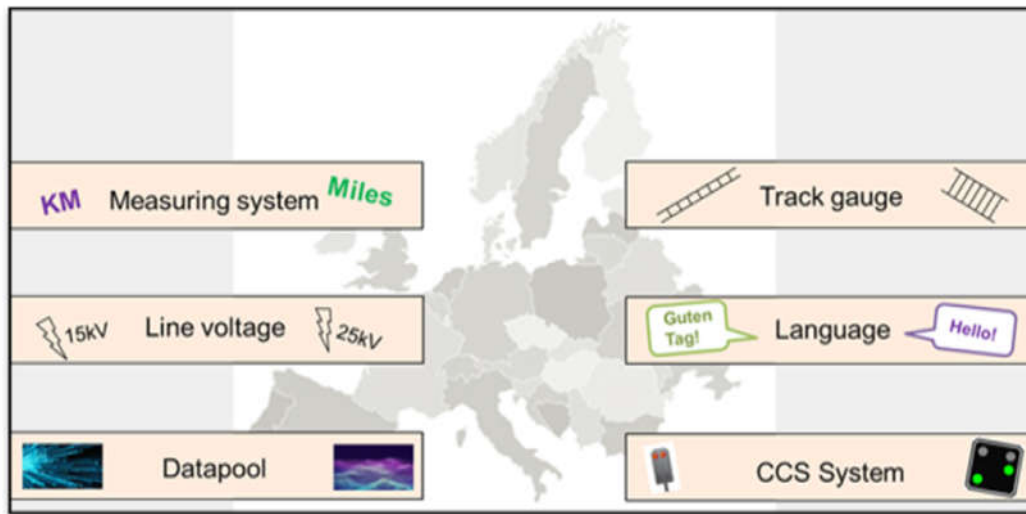

Figure 12-1: Challenges in Europe for coherent data due to different baselines [8]

Technologies and even rules of operation differ among the European countries. There are obvious differences which are easy to handle such as the different measuring systems, track gauges or the thresholds for delay. There are, however, also more hidden differences.

Data can be collected on different aggregation levels. On a high level, there is less data to collect but it is more of a black box what is included in the gained data set. On a less-aggregated level the amount of data that has to be collected increases and with this the effort and consequently the likelihood to not get everything that is needed to perform the assessment. An example for this has been subsidies. Especially infrastructure data can include partially subsidies from the state. When asking for cost data of infrastructure elements on a high level, these values can thus differ a lot. This does not, however, in all cases mean that the cost really varies between individual countries, but it might be due to the fact that they are partially subsidised and therefore reduce the direct cost for the infrastructure manager.

The definition of what a parameter entails goes even further. Operational costs can include energy costs, maintenance and personal costs. Personal costs can, however, be also already included in the maintenance costs to some extent or be a part of the overhead and thus counted towards capital expenditures rather than operational expenditures. A good communication and detailed definition of the data needed is key to be able to compare them and use them further in the model.

All of these challenges have to be met under the premise that a majority of the data, especially when it comes to cost data are highly sensitive and the source shall not be disclosed when used in projects where the end results are publicly available. When using real world scenarios, data to describe these scenarios can often be linked to the source by experts, e.g., which type of trains is described, even if the information is officially disclosed. Therefore, the definition of the scenario that the assessment is performed on is of major importance. To hide the sources of sensitive data, the scenarios that are used in IMPACT-2 are created in such a way that they could be found anywhere in Europe but are not identical with one exact railway line or train

type in a specific country. Another approach to incorporate sensitive data in the model is the number of different sources for one parameter. In the IMPACT-2 project, the most valuable sources are the project partners, among them railway undertakings (RU), infrastructure managers (IM), research companies and industrial rail partners from across Europe. This multitude of sources of expertise has been used in two ways to disclose sensitive data. First, the various sources were used to get multiple values for a set of parameters which could then be averaged or weighted to gain input for the scenario.

With a higher number of independent sources, sensible data can be hidden by using an average across the source when applicable. It also increases the usability for the whole assessment as individual country specifics can be averaged out. When no data could be provided due to confidentiality, e.g., cost data for specific train parts, the sources named above were used to verify the estimated range of the values as well as using distribution rates to, e.g., gather costs of the boogie from the total cost of the train.

## 12.3 Examples from the IMPACT-2 project

In this chapter, two examples from the IMPACT-2 project are described in more detail. First the impact of differing values of time for modal shift calculations is explained and in the following subchapter challenges of data definition on the example of freight train data are described.

### 12.3.1 Value of time data for modal shift calculations

One of the aims of the IMPACT-2 project has been to estimate the potential of Shift2Rail innovations to shift demand to rail from other modes of transport. When it comes to passenger transport, this implies developing a modal shift model which can assess the innovations' potential to attract new travellers from, e.g., car and air to rail. Such modal shift analyses are traditionally in the transport research area conducted using so called logit models, within which each mode has a utility to the traveller which is composed by a known part (travel time, travel cost, waiting time, delays, comfort etc.) and a part unknown to the researcher (random error term). Improvements in the utility of a mode increases the probability that the traveller will choose this mode. The variables in the utility function differ in importance (weight) to the traveller, which in the model is represented by the parameter in front of the variable. The quotient between the travel time and travel cost parameter describes how much value the traveller puts on reductions in travel time in monetary terms and is therefore often called the value of time. Similar valuations can be calculated from the parameters in front of, e.g., waiting time and delay (the value of reducing waiting time/delay). In the modal shift model, these valuations are very important since they determine the effect an improvement in, e.g., waiting time will have on travelers' mode choice. In the context of the IMPACT-2 project, an example of the effect chain looks like this for waiting time: A number of Shift2Rail innovations improves Command Control and Signaling systems and technology → this will make it possible on some corridors to run more trains per hour in the future (possible percentage increase in train frequency as calculated in the KPI model) → increase in train frequency means shorter waiting times for train travellers → the shorter waiting times are included in the modal shift model together with waiting reduction valuations → estimations of increased rail demand is calculated using the modal shift model.



There was no European travel behaviour survey available to the IMPACT-2 project from which traveller valuations of time could be calculated. An available data source was, however, country-specific guidelines for value of time used in cost-benefit analyses (CBA) of infrastructure investments. A challenge was, however, that these differed significantly depending on country. To capture different conditions across Europe, we decided to compare results using valuations from different countries. Three sets of passenger valuations regarding in-vehicle time, access/egress time, waiting time and average delay were compared – a French [9], Swedish [10] and Eastern European Union (EEU) set of valuations, where we calculated the EEU valuations based on a model developed in [11], which included GDP per capita and trip distance (the GDP per capita of EEU was calculated as the population weighted average of GDP per capita of all EEU countries). The latest German value of time guideline [12] is developed according to a different methodology with no variation in value of time across different modes but on the other hand variation across distances, and was therefore difficult to compare to the other guidelines and could not be included in the analysis. The French values of time are higher than Swedish and EEU values of time. Swedish values of time are obtained from a Stated-preference survey. The Swedish value of time calculated by GDP per capita would yield 0.83 €/min for rail in-vehicle time which is much higher than the Swedish value of time according to the guideline, 0.27 €/min. This suggests that value of time calculated using different approaches may differ significantly. It can therefore be necessary to use local values of time measures in valuation of specific corridors/ use cases.

The impact of differing values of time is substantial if the possibility to attract new rail demand is not limited by available track and train capacity. In the IMPACT-2 modal shift results, this is the case for the regional rail corridor application. The results show [13] that Shift2Rail innovations have the potential to increase rail demand on this regional corridor by 118% using French valuations, 102% using Swedish valuations and 58% using EEU valuations. To a large extent these differences are explained by higher valuation of reductions in waiting time and delay in the French and Swedish guidelines.

### **12.3.2 Data for freight train definition**

Additional to the challenges faced for the passenger scenarios, freight scenarios were developed, facing their very own challenges. For rail-bound freight transport, the whole transport chain from terminal to terminal including marshalling yards must be considered, since the processes within the terminals and yards have a huge impact on the transport time and on the number of required locomotives and wagons. Hence, reference parameters must be provided for a lot of assets like locomotives, wagons, terminal, yard, infrastructure, and operation. The parameters must be assessed for the three main freight transport categories single wagon, block, and intermodal trains, which were chosen to be included in the freight scenarios of IMPACT-2.

The most important parameters are the operational data. These are average speed, transport distance, train length, payload, yearly loco- and wagon-km, delay minutes, and loading factor. Here average values of European transports were considered taking into account the requirements mentioned above. They have been provided by Railway Operators and Infrastructure Managers. Further important operational parameters are the process times in terminals and yards. Here a bottom-up assessment was carried out by adding up the detailed

process steps like loading, coupling, shunting and brake test. Additionally, times for delays due to unexpected occurrences are considered.

Some reference data is dependent on the KPI to be assessed. For the cost calculation, average data for transport across Europe is used. But for capacity assessment, data for lines with capacity limits are used, since measures for increasing capacity should increase the capacity of these lines.

One way to increase capacity is by increasing the train length through coupling of short trains on high density lines or by increasing the train length and load with automatic coupling. Another way is through an improved command control and signaling (CCS) system with moving block or virtually-coupled trains. For both measures, the considered train length respectively payload in the underlying scenario is having a high influence on the result.

To decide on train length and payload/loading factor for the three freight transport categories single wagon, block, and intermodal trains, was challenging even though average values were available. While it first needed to be clearly distinguished between the actual average train length and the allowed train length, different regulations and capabilities of infrastructure between and even within European countries led to a wide range of averages in train length and thus also average load factor. So, while European averages were available, a thorough reconsideration, if those were distorted by extremes, needed to be made and the average train length needed to be adapted accordingly.

This has been especially important as train length and load factor feed into several secondary calculations thus influencing the final results on multiple level, e.g., the energy consumption, which was finally assessed by simulating a train run using the reference freight speed profile defined in EN 50931 [14].

The average train length is a good example, that some data, even though it seems simple at first hand and there are values easily available for it, should be reflected upon. Especially, when they influence the results of an assessment significantly.

## 12.4 Conclusion

A comprehensive assessment approach has been developed to ensure that the results can be extrapolated for different use cases in Europe. This has been achieved by developing a multiple-steps- approach using the various industry and railway partners in the Shift2rail innovation projects for an extensive data collection. Not only has data been collected but approaches have been developed to make the large amount of individual data comparable including coherency between data, smoothing over sensitive data, disclosing of differences in wording and definition and the setting of common thresholds.

As the value of time example showed, in cases where it has been impossible to use average data from many input sources the approach explained in chapter 3.1 has been adapted. Instead of using an average, the results have been calculated for each data set individually and the results can then be compared by each stakeholder depending on their research focus. As there

has been no available input data from the EEU for the KPI, it cannot be said if the difference there would be in the same magnitude.

The example of freight highlights the importance of detailed analysis of average values as they can be influenced by various individual factors. This is especially important for input data which feed into multiple secondary calculations thus influencing the final results on several level.

Good communication has in all cases been crucial so that reliable results on a European level could be ensured for the assessment.

## 12.5 References

- [1] ERRAC, "Rail 2030 Research & Innovation Priorities," 2019. [Online]. Available: [https://errac.org/wp-content/uploads/2019/09/errac\\_rail\\_2030\\_research\\_and\\_innovation\\_priorities.pdf](https://errac.org/wp-content/uploads/2019/09/errac_rail_2030_research_and_innovation_priorities.pdf). [Accessed 22 02 2022].
- [2] Europe's Rail Joint Undertaking, "About S2R," 2022. [Online]. Available: <https://shift2rail.org/about-shift2rail/>.
- [3] Shift2Rail, "Shift2Rail Multi-Annual Action Plan (MAAP)," 2015. [Online]. Available: <https://shift2rail.org/publications/multi-annual-action-plan/>.
- [4] IMPACT-2, "D4.1 Initial quantitative KPI model, Vol. 2," 2018.
- [5] IMPACT-2, "D4.3 "Reviewed quantitative KPI model", Vol.1," 2019. [Online]. Available: [https://projects.shift2rail.org/s2r\\_ipcc\\_n.aspx?p=IMPACT-2](https://projects.shift2rail.org/s2r_ipcc_n.aspx?p=IMPACT-2).
- [6] IMPACT-2, "D3.2 SPD application," 2020. [Online]. Available: [https://projects.shift2rail.org/s2r\\_ipcc\\_n.aspx?p=IMPACT-2](https://projects.shift2rail.org/s2r_ipcc_n.aspx?p=IMPACT-2).
- [7] A. Eckert and S. Hainz, "The challenges of unifying railway data in the EU," *Signal+Draht*, vol. 112, no. 7+8, pp. 15-21, 2020.
- [8] S. Hainz and A. Eckert, "Daten-Sharing in Europa - Zwischen Zusammenarbeit und Wettbewerbsabsprache," in *VIMOS-Symposium*, Dresden, 2020.
- [9] C. Gostner, J. Ni, D. Auverlot, B. Delozier and A. Loublie, "Guide to socioeconomic evaluation of public investments in France," Dec 2017. [Online]. Available: <https://www.strategie.gouv.fr/sites/strategie.gouv>. [Accessed 21 02 2020].
- [10] Trafikverket, "Analysmetod och samhällsekonomiska kalkylvärden för transportsektorn: ASEK 6.1," 04 2018. [Online]. Available: [https://www.trafikverket.se/contentassets/4b1c1005597d47bda386d81dd3444b24/asek-6.1/asek\\_6\\_1\\_hela\\_rappo](https://www.trafikverket.se/contentassets/4b1c1005597d47bda386d81dd3444b24/asek-6.1/asek_6_1_hela_rappo). [Accessed 08 05 2019].
- [11] M. Wardman, P. Chintakayala, G. d. Jong and D. Ferrer, ""European wide meta-analysis of values of travel time," *ITS Univ. Leeds Pap. Prep. EIB*," 2012. [Online]. Available: <http://www.significance.nl/papers/2012-European%20wide%20me>. [Accessed 07 02 2017].
- [12] "PTV Group and TCI Röhling, "Methodology Manual for the Federal Transport Infrastructure Plan 2030," R&D Project No.: 97.358/2015, Oct. 2016. Accessed: Sep. 03,

2020. [Online]. Available: [https://www.bmvi.de/SharedDocs/EN/Documents/G/methodology-manual-for,"](https://www.bmvi.de/SharedDocs/EN/Documents/G/methodology-manual-for,) [Online].

[13] IMPACT-2, "D3.3 SPD Result Analysis," 2021. [Online]. Available: [https://projects.shift2rail.org/s2r\\_ipcc\\_n.aspx?p=IMPACT-2](https://projects.shift2rail.org/s2r_ipcc_n.aspx?p=IMPACT-2).

[14] EN 50591 Appendix B "Specification and verification of energy consumption for railway rolling stock".

## 12.6 Acknowledgements

The project IMPACT-2 has received funding from the Shift2Rail Joint Undertaking (JU) under grant agreement No 777513. The JU receives support from the European Union's Horizon 2020 research and innovation programme and the Shift2Rail JU members other than the Union.

Disclaimer: This dissemination of results reflects only the authors' view and the Shift2Rail Joint Undertaking is not responsible for any use that may be made of the information it contains.



## 12.7 Authors



**Alessa Isberner** is scientific staff at the Institute of Transportation Systems of the German Aerospace Center since 2018. Her focus is on the design and impact assessment of new transportation technologies and innovative mobility concepts. She works on assessment in the railway system with microscopic simulation as well as key performance indicator-based methodology.

E-Mail: [alessa.isberner@dlr.de](mailto:alessa.isberner@dlr.de)



**Svenja Hainz** is representing the interest of the German Aerospace Center (DLR e.V.) at European level in the field of transportation research since 2020.

Her duties include the collaboration with European bodies, the engagement in DLR's European strategy processes and the consultancy for DLR's management. She joined DLR in 2017 as scientific staff at the Institute of Transportation Systems. There, she led the development of a Key Performance Indicator (KPI) model assessing the impact of the Shift2Rail programme on the future railway.

E-Mail: [svenja.hainz@dlr.de](mailto:svenja.hainz@dlr.de)



Dr. **Ida Kristofferson** is a Senior Research Leader in the Traffic Analysis and Logistics group at VTI - Swedish National Road and Transport Research Institute. Her research is focused on further development of passenger transport planning models to improve transport forecasts and allow for analysis of transport innovations and new policy measures. She has for several years been involved in projects assessing the potential of rail innovations to increase rail passenger demand.

E-Mail: [ida.kristoffersson@vti.se](mailto:ida.kristoffersson@vti.se)



Dr. **Jürgen Ernst** is working as a senior project manager within Deutsche Bahn. He has a doctor in electrical engineering, more than 25 years industrial experience in innovative railway technology. For several years he has led interdisciplinary teams responsible for carrying out technical projects concerning the whole railway system. Since 2015 he takes part in several Shift2Rail projects. Within the project IMPACT-2 he is responsible for the KPI assessment for freight.

E-Mail: [juergen.ernst@deutschebahn.com](mailto:juergen.ernst@deutschebahn.com)



Dr. **Chengxi Liu** is a researcher at Swedish National Road and Transport Research Institute (VTI). His research focuses on individual travel behavioural modelling, data mining, and travel demand forecasting. He has also been involved in research projects related to various topics, such as unravelling travel behaviour patterns under climate change, modelling and simulations of cyclists, congestion patterns of autonomous vehicles and simulations of railway timetabling.

E-Mail: [chengxi.liu@vti.se](mailto:chengxi.liu@vti.se)

## **13 IMPACT-2 methodology to include customer experience improvements in modal shift estimations**

*Ida Kristoffersson, VTI, Stockholm, Sweden*

*Antoine Verrier, SNCF, Paris, France*

*Chengxi Liu, VTI, Stockholm, Sweden*

*Filiz Kurt, DLR, Institute of Transportation Systems, Braunschweig, Germany*

*Frédéric Getton, SNCF, Paris, France*

*Elodie Vannier, SNCF, Paris, France*

### **13.1 Introduction**

Traditionally, railway innovations have been evaluated based on their technical and economic improvements using key performance indicators (KPIs) such as improvements in capacity, punctuality, and life-cycle cost. Many innovations developed within the European-wide railway research programme Shift2Rail are however focused on improving the experience for railway customers, such as easier ticket booking, more and better information before, during and after the trip, and increased comfort with e.g., wireless internet connection during the trip. Such improvements are not captured by the traditional KPIs. To estimate the potential of Shift2Rail innovations to encourage modal shift and increase rail demand, customer experience improvements need to be included in modal shift analyses. In this paper, the methodology developed within the IMPACT-2 project regarding how to include customer experience improvements in modal shift estimations is described. Furthermore, challenges and constraints for the Customer Experience Model and Modal Shift Model within the IMPACT-2 setting are discussed.

### **13.2 Background – The IMPACT-2 project**

As part of the cross-cutting activities of the Shift2Rail Joint undertaking (S2R), the IMPACT-2 project focuses, inter alia, on the analysis of the socio-economic impacts of the S2R innovations and their impact assessment through the implementation of Key Performance Indicators (KPIs) on System Platform Demonstrators (SPDs). Thereby, the project aims to develop SPD use cases, to carry out an integrated assessment of the S2R innovations based on three KPIs: life-cycle cost, capacity, and punctuality & reliability, as well as to estimate the effects of S2R innovations on customer experience and to calculate the modal shift from competing modes to rail resulting from the Shift2Rail innovations.

As shown in Figure 13-1, three models were developed within the IMPACT-2 project based on S2R objectives: the KPI model, the Customer Experience Model (CE Model), and the Modal Shift Model. The KPI Model estimates the impact of S2R innovations on the S2R targets of halving life cycle costs, doubling capacity and increasing punctuality by 50%. It is the aim of the KPI model to show the maximum achievable improvement as a priority for the respective KPI. In addition to the classic KPIs that focus on economic aspects of the S2R innovations, the Customer Experience Model was developed to consider secondary benefits in terms of customer

satisfaction. The Customer Experience Model specifically identifies areas with high potential for improvement, e.g., increasing the customer satisfaction for the use of the rail system. Finally, the Modal Shift Model was developed to reflect the impact of S2R innovations on the modal shift using the results of the other two models as input.

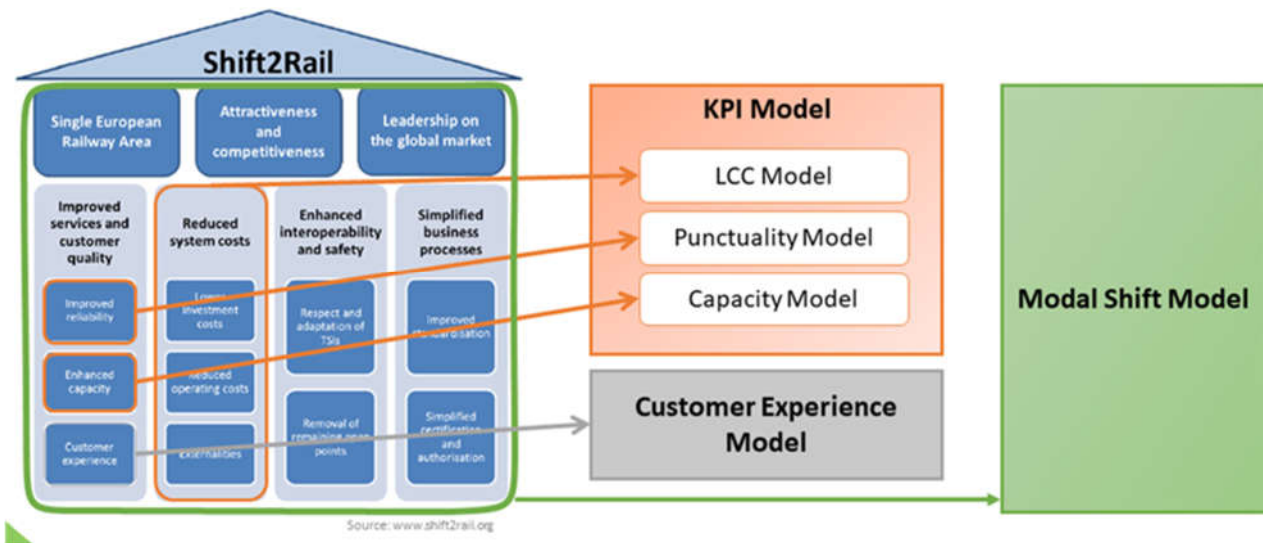

Figure 13-1: Overview of Shift2Rail objectives and the IMPACT-2 models.

### 13.3 Modelling of customer experience improvements

The interrelation between the three IMPACT-2 models is shown in Figure 13-2. The S2R innovations are developed in five Innovation Programmes (IPs). IP1, IP2, IP3, and IP5 are mainly evaluated for their economic impact in terms of LCC, capacity and punctuality through the KPI model. As IP5 deals with freight traffic only, it is not relevant for this paper. Innovations developed in IP4 (and some of the IP1-3 innovations) are assessed using the Customer Experience Model to determine the reduction of barriers for rail passengers. Finally, using the results from the KPI Model and the Customer Experience Model, the Modal Shift Model determines the outcome of the modal shift to rail transport due to the S2R innovations.

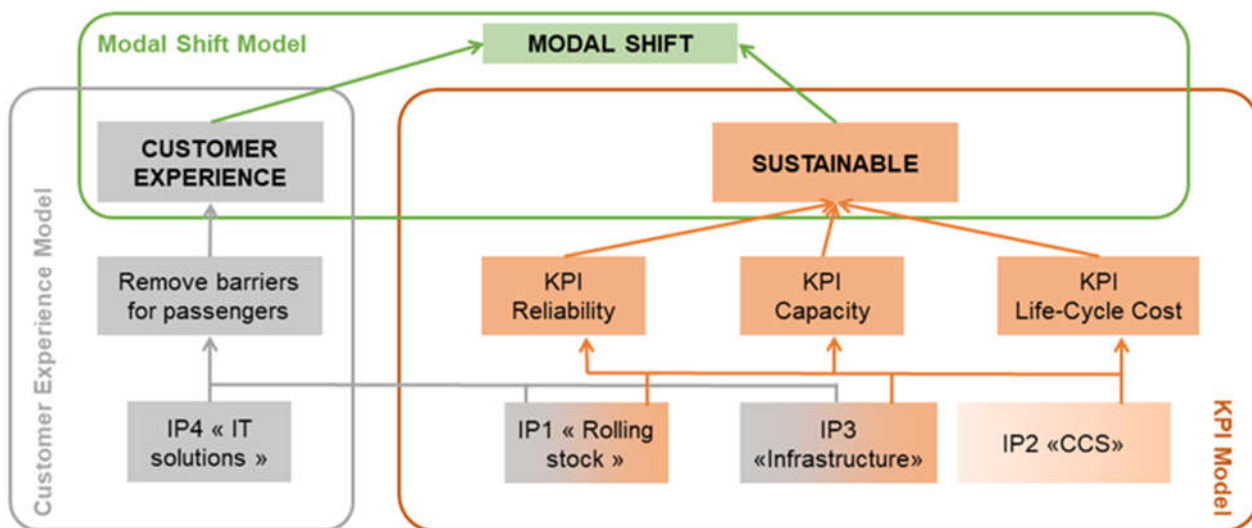

Figure 13-2: Interrelation between the IMPACT-2 models of Shift2Rail for passenger transport.

While Shift2Rail innovation programmes focus on projects' output (e.g., demonstrators, prototypes, reports, etc.), the IMPACT-2 project (part of the cross-cutting activities) concerns how Shift2Rail projects deliver value at the railway system level when combined all together. This approach allows to compute the benefits customers will take advantage and to assess the subsequent modal shift. The IMPACT-2 analysis is centred around four SPD use cases: high-speed passenger rail, regional passenger rail, metro, and rail freight. The Customer Experience Model is not developed for the rail freight SPD since the CE model focuses on passenger satisfaction. Therefore, the focus in this paper is on the first three of these SPDs.

When launching the IMPACT-2 project, a change has taken place in innovation thinking going from an emphasis on technical/economic value only to a broader societal value, i.e., how innovation is perceived from the customers' perspective. However, the connection between these two approaches was missing. The evaluation of customer experience improvements relates to the way customers respond to innovations. The existing literature on innovation management mainly focuses on:

- Value hypotheses (Reis, 2011): how innovation delivers value to customers when they are using it, and how to validate these hypotheses by setting up pragmatic tactics such as speeding up development cycle time with "fail fast" approaches, focusing on actual customers' behaviour rather than on what they are asking for, developing minimum viable products to field-test unfinalized products, dwindling batch sizes, etc.
- Growth hypotheses (Moore, 1991; Rogers, 1962): how innovation is spreading and how it is continuously deployed to meet the needs of increasing number of customers. Innovation lifecycle theories highlight the importance of upstreaming metrics on customer behaviour by building processes flexible enough to systematically test assumptions all over innovation lifecycles.

Innovation management literature focuses on innovative products and services showing a clear set of characteristics against which customer behaviour (willingness to pay -WTP) is assessed. The WTP acts as evidence that innovative products/services deliver value for customers, and it is then translated into financial metrics by feeding Business Models developed at the company level (by definition).

As these approaches (i.e. combining value hypotheses and growth hypotheses) do not fit the requirements of the task definition of IMPACT-2, the Customer Experience Model is based on a "project portfolio approach" which assesses additionality effects between barriers to improve customer experience and improvements in customer experience. Figure 13-3 shows the overall approach of the Customer Experience Model.



**Step 1 : Build a reference scenario per SPD**

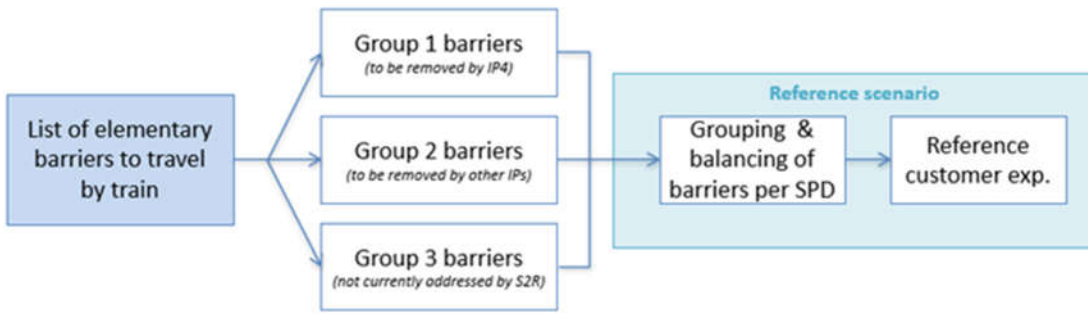

**Step 2 : Estimate the future scenario by assessing S2R impact on the reference scenario**

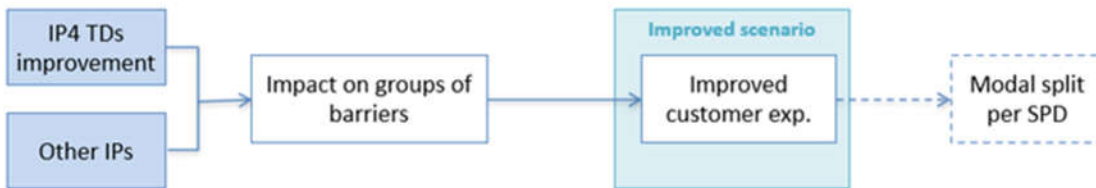

Figure 13-3: Overall approach of the Customer Experience Model of Shift2Rail.

In the first step, a baseline scenario per SPD was developed. Hence, a collection of 250 elementary barriers to travel by train was carried out and then allocated to three different groups, namely barriers that can be removed by IP4, barriers that can be removed by other IPs and barriers that are not addressed by S2R. Following in step two this grouping of barriers, so called “Areas of Major Potential Improvement (AMPIs) were determined and allocated into three CE variables: Booking & Ticketing, Information and Comfort & Service, as shown in Figure 13-4.

Booking and ticketing	Information	Comfort & services
Personalized booking	Real-time information	Train layout
Integrated ticket system	Travel assistant	Train noise
Multimodal shopping	Information on ancillary services	Station design
Simple ticket(s) purchase	Navigation pre/during trip	Station services
Offer adapted to my need	Support in disruption	
<b>AMPIs related to IP4</b>		<b>AMPIs related to IP1 &amp; IP3</b>

Figure 13-4: From elementary barriers to AMPIs

In this process, the customer experience was broken down into its components to identify the data distribution.

ELEMENTARY BARRIERS				1= relevant to Group XXX, 0 = not relevant					
Obstacles	Activities	Source	Type	Group1 Group2				Group3	
				IP4	IP1	IP2	IP3	No	Usi
Access with many luggage	Pre-trip	NEAR2050 Final conf	Access/exit to the station				1		1
Aggravating noise of trains breaking/ departing	On-Trip	Impact-1 DL 2.4				1			1
Annoying passengers	On-Trip	Impact-1 DL 2.4						1	1
Babycare services	On-trip	NEAR2050 Final conf	Services on board					1	1
Bad lighting	On-Trip	Impact-1 DL 2.4						1	1
Bad odors	On-Trip	Impact-1 DL 2.4						1	1
Bad Weather	On-Trip	Impact-1 DL 2.4							0
Barriers	On-Trip	Impact-1 DL 2.4					1		1
Bicycles transport	On-trip	NEAR2050 Final conf	Services on board					1	1
Bike defect	On-Trip	Impact-1 DL 2.4						1	1
Bike Path in bad condition	On-Trip	Impact-1 DL 2.4						1	1
Booking mistake	Pre-Trip	Impact-1 DL 2.4		1					1
Booking seat facilities	Pre-trip	NEAR2050 Final conf	Travel planning	1					1
Bus Station too far	On-Trip	Impact-1 DL 2.4						1	1
Bus Station too far	On-Trip	Impact-1 DL 2.4							0
Cafeteria	On-trip	NEAR2050 Final conf	Services on board					1	1
Check baggage	Pre-trip	NEAR2050 Final conf	Station services					1	1
Closseness from home to the station	Pre-trip	NEAR2050 Final conf	Access/exit to the station					1	1

Figure 13-5: Input data for the CE Model (i.e., components of the customer experience)

Subsequently, the input data was then quantified by determining the relative share of each barrier in customer dissatisfaction, setting this share to 100% in the baseline scenario. In the second step, the relative contribution of Shift2Rail projects to the reduction of these barriers (i.e., customer dissatisfaction) was determined. In the future scenario, the data collection process was standardised by centralising the data from the Shift2Rail innovation programme managers and collected on an annual basis. Figure 13-6, Figure 13-7, and Figure 13-8 shows the CE Model improvement values for the year 2021 for SPD1 high-speed, SPD2 regional, and SPD3 metro respectively. Nevertheless, it should be mentioned, that the outcomes of the Customer Experience Model must be taken with care due to the absence of real-life counterfactual scenarios and the correlation of improvements in customer experience with Shift2Rail projects implementation, allowing to retrieve growing numbers which cannot be verified (“vanity metrics”).

S2R Ips	Unit	AMPI	Unit	Baseline	Improved
				100%	59%
					41%
<b>IP1,2,3</b>	<b>%</b>			<b>19%</b>	<b>1%</b>
Improved Confort and services		Station_Design	%	24%	0%
Improved Confort and services		Station_Services	%	53%	0%
Improved Confort and services		Train_Layout	%	12%	3%
Improved Confort and services		Train_Noise	%	12%	1%
<b>IP4</b>	<b>%</b>			<b>81%</b>	<b>58%</b>
Booking & Ticketing		Personalized_booking	%	9%	6%
Booking & Ticketing		Integrated_ticket_system	%	10%	6%
Improved Information		Real-time_information	%	14%	10%
Booking & Ticketing		Multimodal_shopping	%	9%	8%
Improved Information		Travel_assistant	%	11%	7%
Improved Information		Info_on_ancillary_services	%	7%	3%
Improved Information		Navigation_pre/during_trip	%	9%	7%
Improved Information		Support_in_disruption	%	15%	12%
Booking & Ticketing		Simple ticket(s)_purchase	%	10%	6%
Booking & Ticketing		Offer_adapted_to_my_need	%	8%	5%

Figure 13-6: CE Model Improvement values for SPD1

S2R Ips	Unit	AMPI	Unit	Baseline	Improved
				100%	59%
				100%	41%
<b>IP1,2,3</b>	<b>%</b>			<b>19%</b>	<b>1%</b>
Improved Confort and services		Station_Design	%	26%	0%
Improved Confort and services		Station_Services	%	58%	0%
Improved Confort and services		Train_Layout	%	8%	4%
Improved Confort and services		Train_Noise	%	8%	3%
<b>IP4</b>	<b>%</b>			<b>81%</b>	<b>58%</b>
Booking & Ticketing		Personalized_booking	%	9%	6%
Booking & Ticketing		Integrated_ticket_system	%	10%	6%
Improved Information		Real-time_information	%	12%	9%
Booking & Ticketing		Multimodal_shopping	%	11%	9%
Improved Information		Travel_assistant	%	12%	8%
Improved Information		Info_on_ancillary_services	%	6%	3%
Improved Information		Navigation_pre/during_trip	%	10%	7%
Improved Information		Support_in_disruption	%	14%	12%
Booking & Ticketing		Simple_ticket(s)_purchase	%	10%	7%
Booking & Ticketing		Offer_adapted_to_my_need	%	7%	5%

Figure 13-7: CE Model Improvement values for SPD2

S2R Ips	Unit	AMPI	Unit	Baseline	Improved
				100%	55%
				100%	45%
<b>IP1,2,3</b>	<b>%</b>			<b>25%</b>	<b>1%</b>
Improved Confort and services		Station_Design	%	28%	0%
Improved Confort and services		Station_Services	%	63%	0%
Improved Confort and services		Train_Layout	%	5%	1%
Improved Confort and services		Train_Noise	%	5%	3%
<b>IP4</b>	<b>%</b>			<b>75%</b>	<b>54%</b>
Booking & Ticketing		Personalized_booking	%	6%	4%
Booking & Ticketing		Integrated_ticket_system	%	11%	7%
Improved Information		Real-time_information	%	11%	8%
Booking & Ticketing		Multimodal_shopping	%	14%	12%
Improved Information		Travel_assistant	%	10%	7%
Improved Information		Info_on_ancillary_services	%	3%	1%
Improved Information		Navigation_pre/during_trip	%	13%	10%
Improved Information		Support_in_disruption	%	13%	11%
Booking & Ticketing		Simple_ticket(s)_purchase	%	14%	9%
Booking & Ticketing		Offer_adapted_to_my_need	%	5%	3%

Figure 13-8: CE Model Improvement values for SPD3

Decreasing the barriers to travel by train to 0 at the end of Shift2Rail would not suggest that there are no more barriers but only that all barriers clustered in group 1 and group 2 (compare Figure 13-3) have been removed. This is likely an underestimation of the effect of Shift2Rail on customer experience since the implementation of additional projects ("IKAA") that also contributes to the Shift2Rail Master Plan (Shift2Rail JU, 2019) are not taken into account in group 1 and group 2 barriers.

## 13.4 Including customer experience in the IMPACT-2 Modal Shift Model

As was discussed in the previous section, the customer experience improvements developed within the IMPACT-2 project are aggregated into three variables: Booking & Ticketing, Information, and Comfort & Services. These customer experience variables are not only result output but also inputs to the IMPACT-2 Modal Shift Model, along with the KPI variables (IMPACT-2, 2019) for reduction of average delay (punctuality), improvement in maximum usable track capacity (capacity) and reduction of track and operational costs (life-cycle cost), see Figure 13-9.

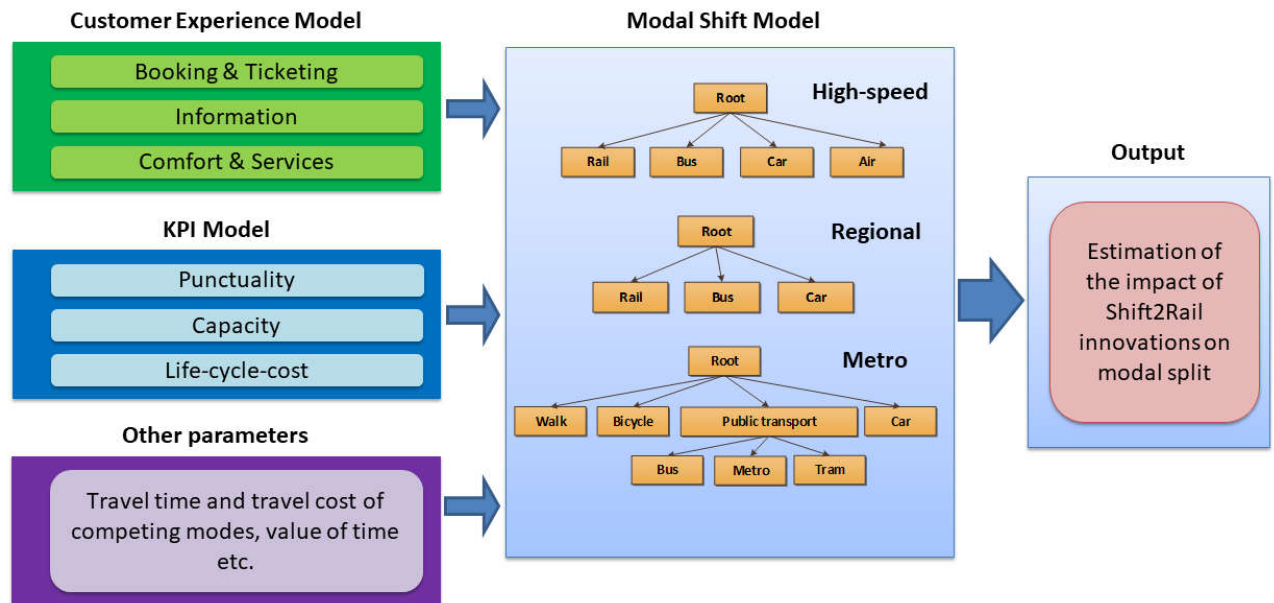

Figure 13-9: Overview of the IMPACT-2 Modal Shift Model for evaluation of Shift2Rail innovations' effects on modal split.

In the IMPACT-2 Modal Shift Model, discrete choice logit models (McFadden, 1974; Train, 2003) are utilized to determine the number of passengers choosing rail in situations with and without Shift2Rail innovations. This way, the Shift2Rail innovations' effects on modal shift can be assessed. The modal shift analysis is conducted for the three different passenger SPDs described in Section 1. Competing modes differ depending on the SPD, e.g., long-distance bus, car, and air are the competing modes in the high-speed use case, see Figure 13-9.

For the IMPACT-2 SPD use cases, utility functions were set up which include customer experience variables, as well as traditional level-of-service variables such as travel time, waiting time, and travel cost. Customer experience variables were included as nominal variables, which are 1 in the baseline and 2 in the Shift2Rail situation, which corresponds to 100% improvement of customer experience barriers (see Section 2). An improvement from Shift2Rail innovations regarding e.g., Booking & Ticketing will thereby increase the utility of rail for the traveller compared to the utility of competing modes. It should be mentioned that the SPD use cases within IMPACT-2 are railway corridors and as such specific: the high-speed use case refers to a high-frequency line in a dense area where demand exceeds capacity, the regional use case is a low-frequency line with capacity limitations at one of the nodes, and the metro use case refers to a line which is already optimised capacity-wise. The possibilities for a metro demand increase

is therefore limited. There are many other types of lines in Europe and the effect of improving customer experience will differ depending on the specific SPD use case. Also, from a customer perspective, the whole trip from door-to-door is important. This is only partly considered in the Modal Shift Model by including average measures of access/egress opportunities and waiting times. For example, none of the SPD use cases included an interchange between two trains.

As there were no possibilities to conduct a large travel behaviour survey within the project IMPACT-2, the valuation of improvements in travel time, waiting time and travel cost consequently are taken from standard values used in national planning. Therefore, the variation in preferences across travellers due to e.g., different socio-economic situations are not considered. Three different standard value of time sets were used as a sensitivity analysis, reflecting the conditions in France, Sweden, and the Eastern European Union (EEU). The valuation of improvements in customer experience variables in comparison to travel time and travel cost improvements was taken from an expert workshop conducted during the IMPACT-2 project. In the workshop, descriptions of the current as well as the improved (Shift2Rail) situation for Booking & Ticketing, Information, and Comfort & Services were presented to the experts. On the example of Comfort & Services in the high-speed use case, the improved situation included WIFI, more comfortable seats, noise and vibration mitigation systems, accessibility for all passengers, shopping facilities in the stations, improved signs with route information, and more seats in the stations. The experts were then asked to state the maximum increase in ticket price that would make them prefer the improved service, i.e., the willingness to pay. Due to the limited participation of experts, the monetary valuation of the customer experience variables was validated against available literature on related customer improvements studies (Carteni et al., 2017; Jou et al., 2013; Watkins et al., 2011). The validation showed similar levels on the monetary valuation of customer experience improvements when the workshop results were compared to valuations from literature.

As three different sets of valuations for value of time, but only one set of valuations for customer experience improvements from one workshop were compared in a sensitivity analysis, the results seemed to show larger effects of customer experience improvements in an EEU setting compared to the French and Swedish setting. In order for the values to be comparable, workshops on the monetary valuation of customer experience improvements need to be conducted for EEU conditions. These workshops could not be carried out within the framework of IMPACT-2.

## 13.5 Discussion

With the CE model a tool has been developed which has been tailored to the needs of IMPACT-2. Within the given time and budget, it fulfils the requirements of capturing the improvements of the qualitative KPI developed in the IPs. Nevertheless, there is room for improvement. The approach of the Customer Experience Model is difficult to extend to the whole Shift2Rail programme due to several reasons:

The first reason is overlapping/missing data. The architecture of the Shift2Rail programme has been designed from a technology-provider perspective and therefore, the impact of each single Shift2Rail project on customer experience may be direct, indirect, or interrelated with other

projects. Moreover, improvements in customer experience often result from several innovations being deployed altogether and establishing links with each single Shift2Rail project is difficult.

Second, the CE model interacts with two other models (i.e., the KPI Model and the Modal Shift Model) which both assume Shift2Rail innovations are fully deployed (i.e., comparing the railway systems in 2013 and 2050) to upstream data on the Shift2Rail “high-level KPIs”. This approach set boundaries for the developed CE model that are contrary to existing literature on innovation management which focuses on phasing the deployment of innovations across different user groups, such as innovators/early adopters/early majority/late majority/laggards (Moore, 1991), over time to ensure gradual market uptake. Customer experience is therefore challenged between two extreme cases: The baseline railway system in 2013 (without Shift2Rail innovations) and the improved railway system when all Shift2Rail innovations are fully deployed. In the absence of simultaneous counterfactual situations to compare customer experience with, it is not possible to in-field measure how customer experience will improve (i.e., no ability to set test-group/control-group) and it must be considered that customer preferences (i.e., distribution data) remain constant over time.

Furthermore, the modelling activities of IMPACT-2 have been designed to assess baseline/improved scenarios among 3 different passenger transport use cases (called “System platform demonstrators – SPDs”, see Section 13-1). SPD characteristics have been described in previous IMPACT-2 deliverables, but these characteristics are technical/economic, and they foresee no data on customer profiles and behaviours. Given the inability to carry out customers surveys on virtual scenarios (by definition), it is therefore not possible to upstream real-life customer data into the modelling activities.

Additionally, assessing customer experience entails using appropriate metrics (and changing metrics if customers find valuable changes over time) for each customer group (different customer groups may have different preferences and different sensitivity to the outcomes of innovation projects). But market surveys meeting such requirements would be expensive and would generate significant input data, thereby raising the issue of comparability (how to capture meaningful insight into all input data at the railway system level?). Within IMPACT-2, the output of the customer experience must be reduced to a low number of manageable variables (three) to be subsequently integrated into the Mode Choice Model, see the green box with CE variable inputs in Figure 13-9.

Assessing improvements in customer experience entails to quantify current customer experience, which requires extensive data on the one hand on customers’ profiles which may vary geographically, e.g., from one country to another, from one railway line to another, etc and on the other hand on customers’ behaviour which may vary with time, especially as the Shift2Rail programme extends over eight years.

Moreover, the systemic nature of the railway industry (rolling stock, infrastructure, CCC systems) and the number of stakeholders involved in delivering/operating the system components makes it difficult to upstream data on how customer experience will be improved by Shift2Rail innovation programmes because:

- Deploying innovation projects in the railway industry requires long incubation/development processes before being able to launch the industrialization phase. This phasing of activities and their duration hardly allow to follow up and upstream KPI on customers experience over the innovation projects' lifetime (up to 15-20 years).
- Ability to upstream indicators on customer experience is limited by:
  - Legal issues such as Intellectual Property Rights on projects' results for each stakeholder participating in the Shift2Rail programme.
  - Confidentiality issues such as sharing sensitive data on customer profiles and preferences with other stakeholders involved in the same industry (and necessity to monitor each single data flow).
  - The number of barriers to customer experience that have been identified within the IMPACT-2 project (around 250 different barriers, 130 of which could be dealt with by at least one of the Shift2Rail projects).

The CE model developed within the framework of the IMPACT-2 project faces the difficulty to merge various input parameters – some of which interrelate with each other – into a consistent model interconnected with two other models. In order to circumvent these difficulties, the model is based on several simplifications related to its general architecture (simplification related to the innovation lifecycle process), to its input data (simplification of the distribution of barriers to customer experience) and to its improvement data (S2R projects' contribution to address these barriers).

## 13.6 Conclusions

In this paper, the methodology developed within the IMPACT-2 modelling system for capturing customer experience improvements has been shown when conducting modal shift analyses of railway innovations. Furthermore, challenges and constraints when developing the models have been discussed.

Estimation of modal shift effects arising from future implementation of railway innovations is a very complex topic and several simplifications need to be made to be able to conduct such an analysis, specifically when data availability is scarce. Early in the IMPACT-2 project it was however realized that customer experience improvements were important for modal shift and needed to be included in the analysis. This is supported by the results of the Modal Shift Model (IMPACT-2, 2020) showing that customer experience improvements have substantial impacts also in relation to the more traditional KPI variables such as capacity, punctuality and life-cycle cost.

Regarding lessons learnt from including customer experience improvements in modal shift analyses, it seems as though the aggregation of customer experience variables into three major areas was a wise choice, since combined with three SPD use cases, it still gives rise to nine different monetary valuations of improved offers to the customers, for which data had to be

provided. The method to include customer experience improvements in modal shift analyses has been described in this paper and seems to work well. It should however be noted that the methodology is simplistic in many ways and can in the future be improved by:

- Considering the dynamics of uptake of customer experience innovations over time – not only the baseline and full deployment situations
- Including a larger variety in customer preferences/valuations instead of using standard national valuations
- Focusing more on the whole journey, i.e., door-to-door travel
- Considering a larger set of use cases that reflects conditions on more lines in Europe

Although the method described in this paper has its drawbacks, it manages to combine both traditional KPI measures and more novel customer experience measures concerning the attractiveness of the railway journey, into inputs for modal shift estimations, showing the importance of development of both technical and passenger-oriented innovations, in order to increase the competitiveness of European rail.

## 13.7 References

- [1] Carteni, A., Pariota, L., & Henke, I. (2017). Hedonic value of high-speed rail services: Quantitative analysis of the students' domestic tourist attractiveness of the main Italian cities. *Transportation Research Part A: Policy and Practice*, 100, 348–365.
- [2] IMPACT-2. (2019). D4.3 Reviewed quantitative KPI model (pp. 1–22).
- [3] IMPACT-2. (2020). D3.3 SPD result analysis (Draft manuscript).
- [4] Jou, R.-C., Chien, J.-Y., & Wu, Y.-C. (2013). A study of passengers' willingness to pay for business class seats of high-speed rail in Taiwan. *Transportmetrica A: Transport Science*, 9(3), 223–238.
- [5] McFadden, D. (1974). *Analysis of Qualitative Choice Behavior*. Zarembka, P.(ed.): *Frontiers in Econometrics*. Academic Press. New York, NY.
- [6] Moore, G. A. (1991). *Crossing the Chasm: Marketing and Selling Technology Products to Mainstream Customers*. New York: Harper Business.
- [7] Reis, E. (2011). *The lean startup: How today's entrepreneurs use continuous innovation to create radically successful businesses*. New York: Crown Business.
- [8] Rogers, E. M. (1962). *Diffusion of innovations*. New York: Free Press of Glencoe.
- [9] Shift2Rail JU. (2019). Shift2Rail JU Multi-Annual Action Plan (MAAP). <https://shift2rail.org/publications/multi-annual-action-plan/>
- [10] Train, K. (2003). *Discrete choice methods with simulation*. Cambridge Univ Pr.
- [11] Watkins, K. E., Ferris, B., Borning, A., Rutherford, G. S., & Layton, D. (2011). Where Is My Bus? Impact of mobile real-time information on the perceived and actual wait time of transit riders. *Transportation Research Part A: Policy and Practice*, 45(8), 839–848.



## 13.8 Acknowledgements

The project IMPACT-2 has received funding from the Shift2Rail Joint Undertaking (JU) under grant agreement No 777513. The JU receives support from the European Union's Horizon 2020 research and innovation programme and the Shift2Rail JU members other than the Union.

Disclaimer: This dissemination of results reflects only the authors' view and the Shift2Rail Joint Undertaking is not responsible for any use that may be made of the information it contains.



## 13.9 Authors



Dr. **Ida Kristoffersson** is a Senior Research Leader in the Traffic Analysis and Logistics group at VTI - Swedish National Road and Transport Research Institute. Her research is focused on further development of passenger transport planning models to improve transport forecasts and allow for analysis of transport innovations and new policy measures. She has for several years been involved in projects assessing the potential of rail innovations to increase rail passenger demand.

E-Mail: [ida.kristoffersson@vti.se](mailto:ida.kristoffersson@vti.se)



**Antoine Verrier** is in charge of public funding management within the SNCF group. He has specialized in innovation funding (European funding, Private Equity, Public procurement, State aids, Tax incentives) and he successively worked in different industries (including air and rail transport) to carry out funding roadshows at various scales all over innovation projects' development stages.

E-Mail: [antoine.verrier@sncf.fr](mailto:antoine.verrier@sncf.fr)

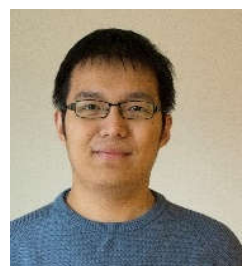

Dr. **Chengxi Liu** is a researcher at Swedish National Road and Transport Research Institute (VTI). His research focuses on individual travel behavioural modelling, data mining, and travel demand forecasting. He has also been involved in research projects related to various topics, such as unravelling travel behaviour patterns under climate change, modelling and simulations of cyclists, congestion patterns of autonomous vehicles and simulations of railway timetabling.

E-Mail: [chengxi.liu@vti.se](mailto:chengxi.liu@vti.se)



**Filiz Kurt M.A.**, is a Research Scientist working in the Department Design and Evaluation of Mobility Solutions at the Institute of Transportation Systems of the German Aerospace Center (DLR) in Germany. As part of the European Joint Undertaking Shift2Rail (S2R) she is working in the IMPACT-2 project of the Cross-Cutting Activities on the development of an integrated KPI methodology to analyze and evaluate the impact of different S2R railway technologies on the overall railway transport system, both for passenger and freight transport, using the KPIs life cycle costs, punctuality, and capacity.

E-Mail: [filiz.kurt@dlr.de](mailto:filiz.kurt@dlr.de)



**Frédéric Getton** is currently Director for Finances & Institutional Relations at the Technology, Innovation and Group Projects Division within SNCF, and in charge of overlooking all public R&D cofunding operations, as well as within its remit the activities of Shift2Rail Joint Undertaking Cross-Cutting Activities, and contributor to the development and implementation of the KPIs methodology.

E-Mail: [frederick.getton@sncf.fr](mailto:frederick.getton@sncf.fr)



**Elodie Vannier** is in charge of public funding management and intellectual property exploitation within the French Infrastructure Manager SNCF Réseau. From 2017 to 2020, she worked in the IMPACT-2 project of Shift2Rail Joint Undertaking Cross-Cutting Activities, as SNCF contributor to the development and implementation of the KPIs methodology.

E-Mail: [elodie.vannier@sncf.fr](mailto:elodie.vannier@sncf.fr)



# 14 Development of energy assessment methodology and simulation tool in Shift2Rail projects FINE1 and OPEUS

*Holger Dittus, DLR, Institute of Vehicle Concepts, Stuttgart, Germany*

*Lukas Pröhl, University of Rostock, Chair of Mechatronics, Rostock, Germany*

## 14.1 Introduction

In times of an increased priority for carbon-free mobility there is also a need for energy efficient and sustainable rail transport. The reduction of the energy demand and environmental impact can also increase the competitiveness of rail in terms of reduced energy costs.

Within the European Shift2Rail (S2R) initiative many projects focussed on technical developments and innovative technologies for rail vehicles such as permanent magnet synchronous motors (PMSM) and silicon carbide (SiC) converters. While these developments have been performed in specific technical projects, often with their own application-specific use cases and objectives, no standardised process to assess the impact of the new developments on energy demand was defined.

Hence, in addition to the technical projects, S2R established additional projects for so called cross-cutting activities. One of these projects was FINE1 Future Improvement for Energy and Noise [1]. FINE1 high level objectives related to energy are to assess energy demand and to support the quantification of energy improvements of new technologies with a standardized approach. Within this paper, the process developed and used in the S2R project FINE1 for the evaluation of energy demand is presented. This includes the following:

- A methodology for simulation and prediction of energy demand
- An overview of the energy simulation tool that has been developed
- The reference railway use cases and applications used as energy baseline
- Exemplary results of the energy demand assessment for selected S2R technical developments

## 14.2 Simulation Methodology and Development of Energy Simulation Tool

The objective of this work is to develop the simulation methodology to systematically assess the improvements in terms of energy demand of the innovations, which are developed within the S2R Technical Demonstrators (TDs). The methodology and simulation tool have been developed in close collaboration with the Horizon 2020 project OPEUS [2]. While here only an overview of the requirements can be provided, a detailed description is documented in the FINE1 Deliverable D3.4 Requirement Specification for Energy Simulation Tool [3].

The requirements specification for the energy simulation tool and for the prediction of energy demand include amongst others the definition of the modules and parameters that should be considered in the simulation models. The high level requirements for the simulation tool are displayed in Figure 14-1.

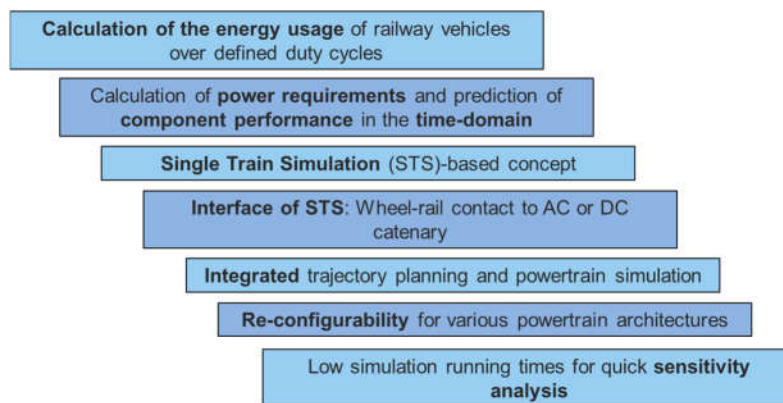

Figure 14-1: Energy Simulation Tool High Level Requirements

From the energy perspective, driving under standard conditions is the relevant case to be investigated when analysing energy improvements due to technical innovations. Degraded modes are of minor significance in terms of overall energy usage; nevertheless, they are certainly relevant when designing a technical system.

The general approach is based on a backward-facing simulation approach with behavioural modelling of the components. The intention is to avoid going too deep into the physical details of each component and component variant. Thus, the focus is on power flows, while physical modelling of specific characteristics, such as the effect of harmonics in traction drives, are excluded. In the backward-facing approach, the wheel forces are calculated directly from the speed profiles, taking into account resistance forces such as rolling or aerodynamic resistance. The obtained forces are then translated into torque and power values. These are then calculated against the flow of traction power through a powertrain model, which consists of all powertrain components for the specific vehicle configuration. The energy demand is finally determined at the interface to the energy source, for example at the contact point of catenary and pantograph. This approach allows usage of efficiency maps to model the components behaviour.

The OPEUS energy simulation tool [4] includes the infrastructural and operational boundary conditions of the line(s) to be simulated such as gradients, line speed limitations, curve radii, station positions and timetables. First a trajectory planning is performed that determines a train speed profile and the corresponding power profile at the wheels. This trajectory planning uses acceleration and deceleration limits in normal operation conditions, hence not being subject to adhesion limitations. These two profiles are used as input for the traction system models. The traction system are modelled by combination of stand-alone component modules, which allows to reuse already developed models and parameters also for other traction topologies.

Figure 14-2 exemplary shows the AC traction topology T01 with a conventional transformer. Each component module is labelled with a unique identifier. The model also allows integration of energy storage systems for the simulation of bi-mode or series hybrid traction architectures.

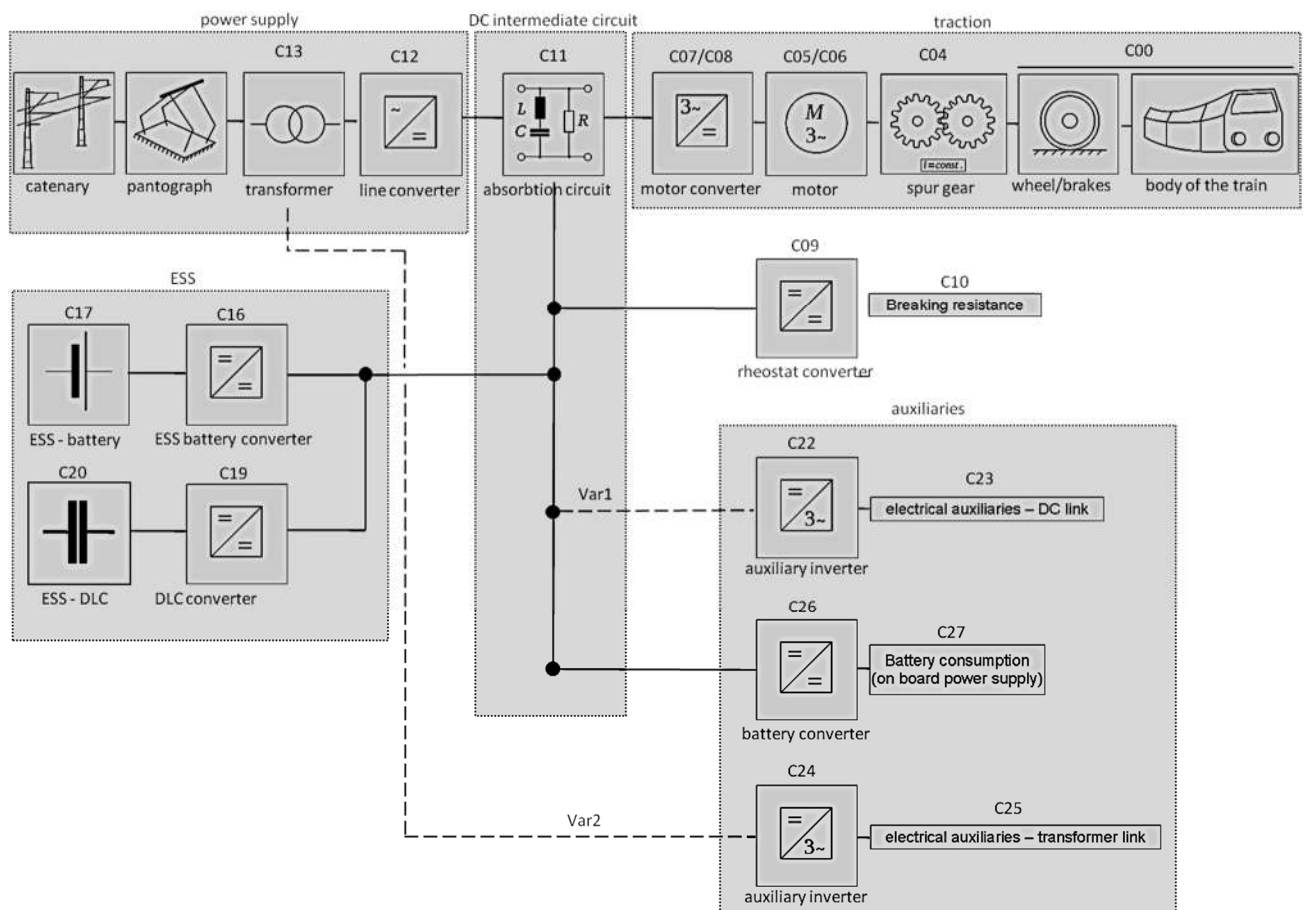

Figure 14-2: Example of AC traction topology T01 with component modules

Within the FINE1 and OPEUS projects the energy simulation tool has been validated by the project partners in two steps. Firstly, the tool was checked against the functional design requirements defined in FINE1 deliverable D3.4 Requirement Specification for Energy Simulation Tool [3]. Secondly, the tool's calculation methodology was checked via simulation of predefined train configurations and comparison of the results against established tools or measurements of the individual project partners that performed the validation. The main conclusion of the aforementioned two-step-process is that the developed OPEUS energy simulation tool fulfils the requirements and is approved for energy assessment activities and the evaluation of energy Key Performance Indicators (KPI) within the S2R FINE1.

## 14.3 Energy Baseline

The FINE1 deliverable D3.1 Energy Baseline [5] describes the reference parameters and scenarios for assessing the improvements of Shift2Rail innovations with respect to energy. The Deliverable D3.1 includes:

- The analysis of operational scenarios and reference speed profiles for the S2R system platform demonstrators (SPDs) concerning the traffic segments high speed, regional, urban and freight.

- The analysis of State-of-the-art technology characteristics with respect to energy of railway subsystems (vehicles, infrastructure, command & control system, energy supply).
- The definition of simulation data of reference technologies and reference vehicles

The defined simulation data contains the Service Profiles for the simulation of single train runs. Service Profiles are defined as invented in the standard EN50591 Specification and verification of energy consumption [6] and describe the boundary conditions of the lines and timetables for a train run. While energy demand or fuel consumption of road vehicles is typically measured in a predefined speed profile with speed as a function of time, the service profile approach defined in EN50591 is based on typical train runs in passenger transport. This service profile approach assumes that a train runs on a defined line consisting of a track description and a timetable. The track is characterised by the stations and their positions, the speed limits in different sections and the track gradients with their positions. The timetable defines arrival, stop and departure times at several or all stations, depending on the type of service profile, i.e. high speed, intercity, regional, etc. The timetable defines a fixed journey time, either for the complete line or section by section. This journey time can be exploited to choose the driving style with respect to the performance characteristics of the vehicle, and if the vehicle performance is sufficient to create a time reserve, energy efficient driving style can be applied, for example by a driver assistance system (DAS).

In addition to the service profiles the Energy Baseline simulation data also defines the complete set of generic parameters for the reference vehicles, for example for high speed, intercity, regional and metro applications. These are more than 150 parameters for each train configuration which can be summarised under the main categories:

- Train parameters such as train design mass and payload, train dimensions, traction topology, passenger capacity, number of seats, etc.
- Train resistance parameters, tractive effort and brake effort characteristics, max. train speed, electro-dynamic braking capabilities, etc.
- Detailed power characteristics and efficiency parameters describing traction components such as traction drives, traction/aux/line converters, transformer, energy storage systems, gear box, etc.
- Heating, ventilation, air conditioning (HVAC) and further parameters from other auxiliary consumers.

For a detailed list of parameters see FINE1 Deliverable D3.3 Future Railway System [7].

## 14.4 Exemplary Results

Within FINE1 and OPEUS projects the energy simulation tool has been applied to assess and compare the energy demand of energy baseline with several novel technologies and components that have been developed in the S2R TDs and SPDs, to quantify the potential

energy reduction of these subsystems. The process for energy savings assessment is exemplary shown in Figure 14-3.

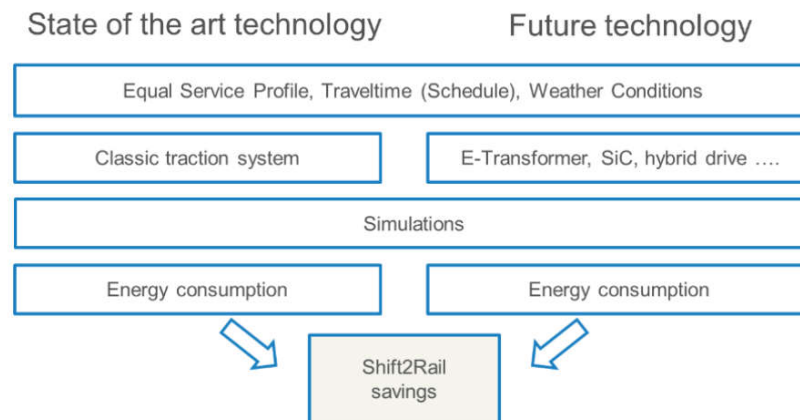

Figure 14-3: Assessment of S2R future technology energy savings and comparison to energy baseline (state of the art)

The key performance indicator “energy KPI” is used to quantify the relative change in energy demand between baseline and future technologies. The KPI improvements (Figure 14-4) presented in this paper are focused on combined effects due to mass reductions and improvements of SiC converter efficiency.

The potential mass reductions due to technical improvements on train level range between 2.38% in High Speed SPD, 0.22% in Intercity SPD, 0.54% in Regional SPD, 0.51% in Metro SPD and 1.03% in Tram SPD [8].

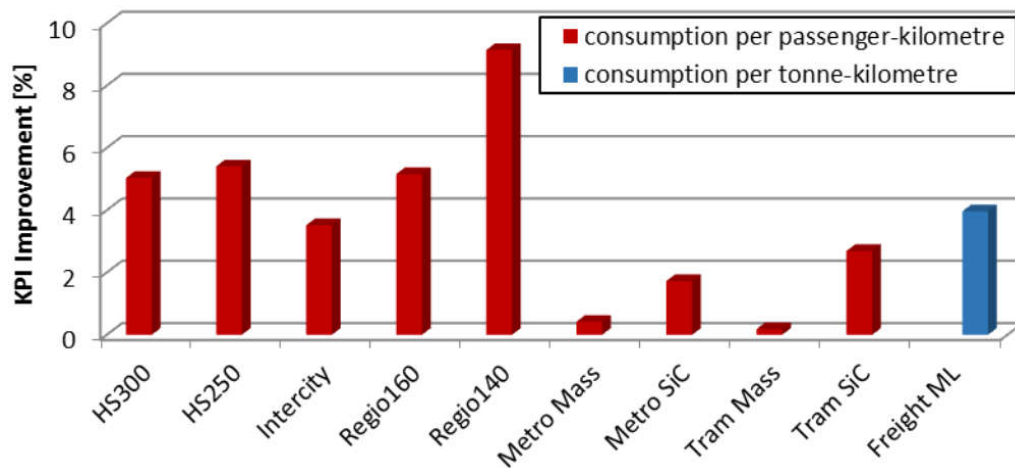

Figure 14-4: Energy KPI improvement for the combination of mass reductions and SiC converter.

For Metro and Tram the improvements are displayed separately. [8]

For those SPDs where calculation of integrated energy KPIs was feasible, the resulting improvements of energy KPI range between 3.5% for SPD Intercity and 9.1% for SPD Regional140. In Metro and Tram SPD a separate assessment of different technologies was performed, showing the potential of SiC converter application with 1.7% energy KPI improvement for Metro SPD and 2.7% for Tram SPD. In these SPDs the quite small relative mass



reductions (-0.51% in both cases) resulted in 0.4% energy savings for Metro SPD and 0.18% for Tram SPD; the improvement of energy KPI due to mass reductions is therefore negligible for SPD Metro and SPD Tram.

## 14.5 Summary and Conclusion

Within the S2R FINE1 and OPEUS projects an energy simulation tool for single train runs has been designed, implemented and benchmarked against existing tools of industrial and research partners. Together with the tool the state of the art with respect to energy demand of railway vehicles in different applications has been defined and documented as so called energy baseline.

The energy simulation tool and the underlying methodology have been applied to assess the improvement of the energy KPI due to different technical solutions that have been developed in the S2R technical projects. Within this paper the potential energy demand reduction due to the application of SiC converter technology and due to weight reduction have been exemplarily presented for different system platforms. The potential energy savings range between 1% and 9%, depending on the type of vehicle, with regional trains showing the best potential in this analysis.

The presented energy simulation tool is currently in use in the FINE1 follow-up project FINE-2 [9], where it is used to assess the energy saving potentials of new or further improved technologies and components that have been developed in the S2R technical projects since FINE1 ended in October 2019.

## 14.6 References

- [1] Shift2Rail FINE 1 Future Improvement for Energy and Noise, Grant Agreement No 730818, [https://projects.shift2rail.org/s2r\\_ipcc\\_n.aspx?p=FINE%201](https://projects.shift2rail.org/s2r_ipcc_n.aspx?p=FINE%201)
- [2] Shift2Rail OPEUS Modelling and strategies for the assessment and OPTimisation of Energy USage aspects of rail innovation, Grant Agreement No 730827, [https://projects.shift2rail.org/s2r\\_ipcc\\_n.aspx?p=OPEUS](https://projects.shift2rail.org/s2r_ipcc_n.aspx?p=OPEUS)
- [3] Shift2Rail FINE1 D3.4 Requirement Specification for Energy Simulation Tool, Grant Agreement No 730818, <https://projects.shift2rail.org/download.aspx?id=d29b84a6-a45e-4646-bf95-647e78b81197>
- [4] Shift2Rail OPEUS D2.1 OPEUS simulation package, Grant Agreement No 730827, <https://projects.shift2rail.org/download.aspx?id=4e263299-f224-41e4-9cc2-6fc991bd56ef>
- [5] Shift2Rail FINE1 D3.1 Energy Baseline, Grant Agreement No 730818, <https://projects.shift2rail.org/download.aspx?id=ab79020c-bcd8-48c2-8388-24b3b41092b2>
- [6] EN50591:2019 Railway Applications - Rolling Stock - Specification and verification of energy consumption

- [7] Shift2Rail FINE1 D3.3 Future Railway System, Grant Agreement No 730818, <https://projects.shift2rail.org/download.aspx?id=d29b84a6-a45e-4646-bf95-647e78b81197>
- [8] Shift2Rail FINE1 D4.7 Evaluation of Energy KPI – final, Grant Agreement No 730818, <https://projects.shift2rail.org/download.aspx?id=8e254a94-5e72-4b34-8e89-afa55efae401>
- [9] Shift2Rail FINE-2 Furthering Improvements in Integrated Mobility Management (I2M), Noise and Vibration, and Energy in Shift2Rail, Grant Agreement No 881791, [https://projects.shift2rail.org/s2r\\_ipcc\\_n.aspx?p=fine-2](https://projects.shift2rail.org/s2r_ipcc_n.aspx?p=fine-2)

## 14.7 Acknowledgements

The FINE1 project has received funding from the Shift2Rail Joint Undertaking (JU) under grant agreement No 730818. The JU receives support from the European Union's Horizon 2020 research and innovation programme and the Shift2Rail JU members other than the Union. The OPEUS project has received funding from the European Union's Horizon 2020 research and innovation programme under grant agreement No: 730827. The paper reflects only the authors' view, the JU is not responsible for any use that may be made of the information it contains.



## 14.8 Authors



**Holger Dittus** is a researcher, group leader and project coordinator at Deutsches Zentrum für Luft- und Raumfahrt e.V. (DLR), Germany. He received a degree in Mechanical Engineering (Dipl.-Ing) from RWTH Aachen in 2006. His scientific scope is in energy management for railway vehicles with alternative traction systems, hybrids, BEMUs and fuel cell vehicles. He is Project Coordinator of the EU-Horizon 2020 Project FCH2RAIL since 2021, Project Manager of the DLR Project Propulsion & Coupling (ProCo) since 2022 and he participated in EU S2R-projects Roll2Rail, FINE1, FINE2, X2Rail-3 and in standardization group for EN 50591:2018 Specification and verification of energy consumption for railway rolling stock.

E-Mail: holger.dittus@dlr.de



**Lukas Pröhl** holds a M.Sc. in Mechanical Engineering and is a research scientist at the chair of mechatronics at the University of Rostock. In the scope of research and teaching he is dealing with the modelling and control of mechatronics systems as well as the investigation and application of innovative optimization techniques.

Within OPEUS his focus was on the Matlab implementation of the OPEUS-tool as well as the application of optimization approaches for energy optimized driving & ESS strategies.

E-Mail: Lukas.proehl@uni-rostock.de

## 15 Authors Index

Abderrahman, A. ....	97	Kurt, F. ....	97, 117
Arrizabalaga, S. ....	83	Liu, C. ....	109
Badis, H. ....	63	Liu, X. ....	117
Berbineau, M. ....	1, 63	Marlière, G. ....	55
Beugin, J. ....	19	Masson, E. ....	1
Brinkmann, F. ....	47	Mechal Molla, D. ....	63
Clarhaut, J. ....	19	Mendizabal, J. ....	1, 29
De Miguel, G. ....	29	Meyer zu Hörste, M. ....	1, 11, 97
Debbeck, S. ....	83	Pellegrini, P. ....	55
Dittus, H. ....	131	Pesenti, R. ....	55
El-Koursi, E. ....	19, 37	Prieels, P. ....	11
Ernst, J. ....	97, 109	Pröhl, L. ....	131
Errandonea, I. ....	83	Rahmig, C. ....	83
Getton, F. ....	117	Renaux, D. ....	19
Ghazel, M. ....	37	Rodriguez, J. ....	55
Goya, J. ....	29	Sabra, A. ....	63
Hainz, S. ....	109	Sassi, I. ....	19, 37
Hutchinson, M. ....	1	Scheier, B. ....	47
Isberner, A. ....	47, 97, 109	Seetharamdoo, D. ....	73
Izquierdo, D. ....	29	Vannier, E. ....	117
Kalaagi, M. ....	73	Verrier, A. ....	117
Kristofferson, I. ....	109, 117	Yi, X. ....	55